



An Ideal Interface for Easily Measuring the Time Interval

- 50-kHz input range and 0.08% FS accuracy for sophisticated control
- Select: relay, transistor, BCD, linear, or communications outputs
- Maximum/minimum value hold, set value write protection, and more
- Set value teaching, linear output range teaching, and prescale teaching are available using actual units measured
- Prescale function available (displays in actual units of length, volume, etc.)
- Auxiliary power supply (12 VDC, 80 mA)
- NEMA4/IP66 front panel
- UL, CSA, and CE approved



Ordering Information

■ BASE UNIT

Model	Supply voltage	Applicable output boards	Part number	
			Input type	
			NPN/ Voltage pulse	PNP
Basic model  Present value LED and front-panel control keys. Can connect to any output board or, without an output board, can be used for display only.	100 to 240 VAC	K31-C1/C2/C5 K31-T1/T2 K31-B2/B4 K31-L1/L2/L3/L4/L5/L6/ L7/L8/L9/L10 K31-FLK1/FLK2/FLK3/FLK4/ FLK5/FLK6	K3NP-NB1A	K3NP-PB1A
	12 to 24 VDC		K3NP-NB2A	K3NP-PB2A
Set value LED model  Present value LED, set value LED, and front panel control keys. Can connect to relay, transistor, or combination output boards.	100 to 240 VAC	K31-C1/C2/C5 K31-T1/T2 K31-B4 K31-L4/L5/L6/L9/L10 K31-FLK4/FLK5/FLK6	K3NP-NB1C	K3NP-PB1C
	12 to 24 VDC		K3NP-NB2C	K3NP-PB2C

Note: "Set Value LED" models must be used with an output board in order for them to operate.

■ AVAILABLE OUTPUT BOARD COMBINATIONS

Output type	Output configuration	Part number
Relay contact	3 outputs: H, PASS, L (SPDT)	K31-C1
	5 outputs: HH, H, L, LL (SPST-NO), and PASS (SPDT)	K31-C2
	5 outputs: HH, H, L, LL (SPST-NC), and PASS (SPDT)	K31-C5
Transistor	5 outputs (NPN open collector)	K31-T1
	5 outputs (PNP open collector)	K31-T2
BCD (See Note.)	5-digit output (NPN open collector)	K31-B2
Linear	4 to 20 mA DC	K31-L1
	1 to 5 VDC	K31-L2
	1 mV/10 digits	K31-L3
	0 to 5 VDC	K31-L7
	0 to 10 VDC	K31-L8
Communication boards (See Note.)	RS-232C	K31-FLK1
	RS-485	K31-FLK2
	RS-422	K31-FLK3
Combination output and communication boards	BCD output + 5 transistor outputs (NPN open collector)	K31-B4
	4 to 20 mA + 5 transistor outputs (NPN open collector)	K31-L4
	1 to 5 V + 5 transistor outputs (NPN open collector)	K31-L5
	1 mV/10 digits + 5 transistor outputs (NPN open collector)	K31-L6
	0 to 5 VDC + 5 transistor outputs (NPN open collector)	K31-L9
	0 to 10 VDC + 5 transistor outputs (NPN open collector)	K31-L10
	RS-232C + 5 transistor outputs (NPN open collector)	K31-FLK4
	RS-485 + 5 transistor outputs (NPN open collector)	K31-FLK5
	RS-422 + 5 transistor outputs (NPN open collector)	K31-FLK6

Note: For details, refer to the *Communication in the Operation Manual* (N96).

■ MODEL NUMBER LEGEND

Base units and output boards are available individually. Refer to the *Available Output Board Combinations* table provided within *Ordering Information*.

Base Units

K3NP -
 1 2 3 4

1, 2. Input Sensors Codes

NB: NPN inputs
 PB: PNP inputs

3. Supply Voltage

1: 100 to 240 VAC
 2: 12 to 24 VDC

4. Display

A: Basic Model
 C: Set Value LED Display

Specifications

■ RATINGS

Supply voltage		100 to 240 VAC (50/60 Hz); 12 to 24 VDC
Operating voltage range		85% to 110% of supply voltage
Power consumption (See Note.)		15 VA max. (max. AC load with all indicators lit) 10 W max. (max. DC load with all indicators lit)
Sensor power supply		80 mA at 12 VDC±10%
Insulation resistance		20 MΩ min. (at 500 VDC) between external terminal and case. Insulation provided between inputs, outputs, and power supply.
Dielectric withstand voltage		2,000 VAC for 1 min between external terminal and case. Insulation provided between inputs, outputs, and power supply.
Noise immunity		±1,500 V on power supply terminals in normal or common mode ±1 μs, 100 ns for square-wave noise with 1 ns
Vibration resistance		Malfunction: 10 to 55 Hz, 0.5-mm for 10 min each in X, Y, and Z directions Destruction: 10 to 55 Hz, 0.75-mm for 2 hrs each in X, Y, and Z directions
Shock resistance		Malfunction: 98 m/s ² (10G) for 3 times each in X, Y, and Z directions Destruction: 294 m/s ² (30G) for 3 times each in X, Y, and Z directions
Ambient temperature	Operating	-10 to 55°C (14 to 131°F) with no icing
	Storage	-20 to 65°C (-4 to 149°F) with no icing
Ambient humidity	Operating	25% to 85% (with no condensation)
Ambient atmosphere		Must be free of corrosive gas
EMC		Emission Enclosure: EN55011 Group 1 class A Emission AC Mains: EN55011 Group 1 class A Immunity ESD: EN61000-4-2: 4-kV contact discharge (level 2) 8-kV air discharge (level 3) Immunity-RF-interference: ENV50140: 10 V/m (amplitude modulated, 80 MHz to 1 GHz) (level 3) 10 V/m (pulse modulated, 900 MHz) Immunity Conducted Disturbance: ENV50141: 10 V (0.15 to 80 MHz) (level 3) Immunity Burst: EN61000-4-4: 2-kV power-line (level 3) 2-kV I/O signal-line (level 4)
Approved standards		UL508, CSA22.2; conforms to EN50081-2, EN50082-2, EN61010-1 (IEC1010-1); conforms to VDE106/part 100 (Finger Protection) when the terminal cover is mounted.
Weight		Approx. 400 g

Note: An Intelligent Signal Processor with DC supply voltage requires approximately 1 A DC as control power supply current the moment the Intelligent Signal Processor is turned on. Do not forget to take this into consideration when using several Intelligent Signal Processors. When the Intelligent Signal Processor is not in measuring operation (e.g., the Intelligent Signal Processor has just been turned on or is operating for startup compensation time), the display will read "00000" and all outputs will be OFF.

■ INPUT/OUTPUT RATINGS

Relay Contact Output (Incorporating a G6B Relay)

Item	Resistive load ($\cos\phi = 1$)	Inductive load ($\cos\phi = 0.4$, L/R = 7 ms)
Rated load	5 A at 250 VAC; 5 A at 30 VDC	1.5 A at 250 VAC, 1.5 A at 30 VDC
Rated carry current	5 A max. (at COM terminal)	
Max. contact voltage	380 VAC, 125 VDC	
Max. contact current	5 A max. (at COM terminal)	
Max. switching capacity	1,250 VA, 150 W	375 VA, 80 W
Min. permissible load (P level, reference value)	10 mA at 5 VDC	
Mechanical life	50,000,000 times min. (at a switching frequency of 18,000 times/hr)	
Electrical life (at an ambient temperature of 23°C)	100,000 times min. (at a rated load switching frequency of 1,800 times/hr)	

Transistor Output

Rated load voltage	12 to 24 VDC $+10\%/-15\%$
Max. load current	50 mA
Leakage current	100 μ A max.

BCD Output

I/O signal name	Item	Rating
Inputs	REQUEST, HOLD, MAX, MIN, RESET	No-voltage contact input
	Input current with no-voltage input	10 mA
	Signal level	ON voltage: 1.5 V max. OFF voltage: 3 V min.
Outputs	DATA, POLARITY, OVERFLOW, DATA VALID, RUN	Rated load voltage
	Max. load current	10 mA
	Leakage current	100 μ A max.

Note: Logic method: negative logic

Linear Output

Item	4 to 20 mA	1 to 5 V	1 mV/10 digits (See Note.)
Resolution	4,096		
Output error	$\pm 0.5\%$ FS	$\pm 1.5\%$ FS	
Permissible load resistance	600 Ω max.	500 Ω min.	1 K Ω min.

Note: For the 1 mV/10-digit output, the output voltage changes for every 40 to 50 increment in the display value.

■ COMMUNICATIONS

Item	RS-232C, RS-422	RS-485
Transmission method	4-wire, half-duplex	2-wire, half-duplex
Synchronization method	Start-stop synchronization	
Baud rate	1200/2400/4800/9600/19200/38400 bps	
Transmission code	ASCII (7-bit)	
Communications	Write to K3NP	Comparative set value, prescaling value, remote/local programming, reset control of maximum/minimum values, and other setting mode items excluding communications conditions
	Read from K3NP	Process value, comparative set value, maximum value, minimum value, model data, error code, and others

For details, refer to the *Communication Operation Manual* (N96).

■ CHARACTERISTICS

Input signal	No-voltage contact (30 Hz max., ON/OFF pulse width: 15 ms min.) Voltage pulse (50 kHz max., ON/OFF pulse width: 9 μs min., ON voltage: 4.5 to 30 V/OFF voltage: -30 to 2 V) Open collector (50 kHz max., ON/OFF pulse width: 9 μs min.) Connectable Sensors ON residual voltage: 3 V max. OFF leakage current: 1.5 mA max. Load current Transistor input: Must have switching capacity of 20 mA min. Contact input: Must be able to dependably switch a load current of 5 mA max.	
Measuring accuracy (at 23±5°C)	±0.08%rdg±1 digit	
Measuring modes and ranges	Operating mode 1: Passing speed 10 ms to 3,200 seconds Operating mode 2: Cycle 20 ms to 3,200 seconds Operating mode 3: Time difference 10 ms to 3,200 seconds Operating mode 4: Elapsed time 10 ms to 3,200 seconds Operating mode 5: Length measurement 0 to 4G count (32-bit counter) Operating mode 6: Interval 0 to 4G count (32-bit counter)	
Max. displayed digits	5 digits (0 to 99999)	
Display	7-segment LED	
Polarity display	Not available	
Zero display	Leading zeros are not displayed.	
Prescale function	Programming via front-panel key inputs. (0.0001 x 10 ⁻⁹ to 9.9999 x 10 ⁹ , decimal point can be set freely) Can be set using prescale value teaching.	
HOLD functions	Max. value (peak) hold, Min. value (bottom) hold	
External control	HOLD: Process value held RESET: Maximum/minimum data reset BANK: Selection of one bank out of 4 banks of set values Selection of one bank out of 4 banks of prescale values	
Other functions	Variable linear output range (for models with linear outputs only) (See Note.) Remote/Local processing (available for communications output models only) Maximum/Minimum value data reset with front panel keys Comparative output pattern selection Time unit display Security	
Output configuration	Relay contact output (3 or 5 outputs) Transistor output (NPN and PNP open collector), BCD (NPN open collector) Parallel BCD (NPN open collector) + transistor output (NPN open collector) Linear output (4 to 20 mA, 1 to 5 V) + transistor output (NPN open collector) Communication functions (RS-232C, RS-485, RS-422) Communication functions (RS-232C, RS-485, RS-422) + transistor output (NPN open collector)	
Delay in comparative outputs (at transistor output)	20 ms max.	
Enclosure rating	Front panel	NEMA4 for indoor use (equivalent to IP66)
	Rear case	IEC standard IP20
	Terminals	IEC standard IP00
Memory protection	Non-volatile memory (EEPROM) (possible to rewrite 100,000 times)	

Note: The linear output range cannot be set when connected to a 1 mV/10-digit Linear Output Board.

Engineering Data

DERATING CURVE FOR SENSOR POWER SUPPLY

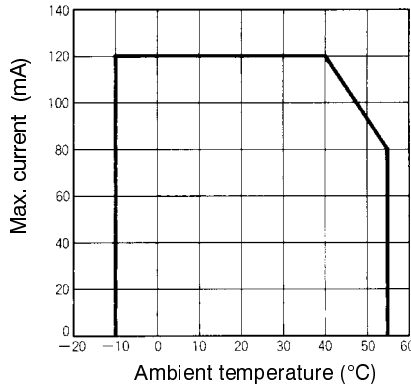

Note: The derating curve shown is for standard installation.
The derating curve depends on the mounting direction.

Nomenclature

K3NP

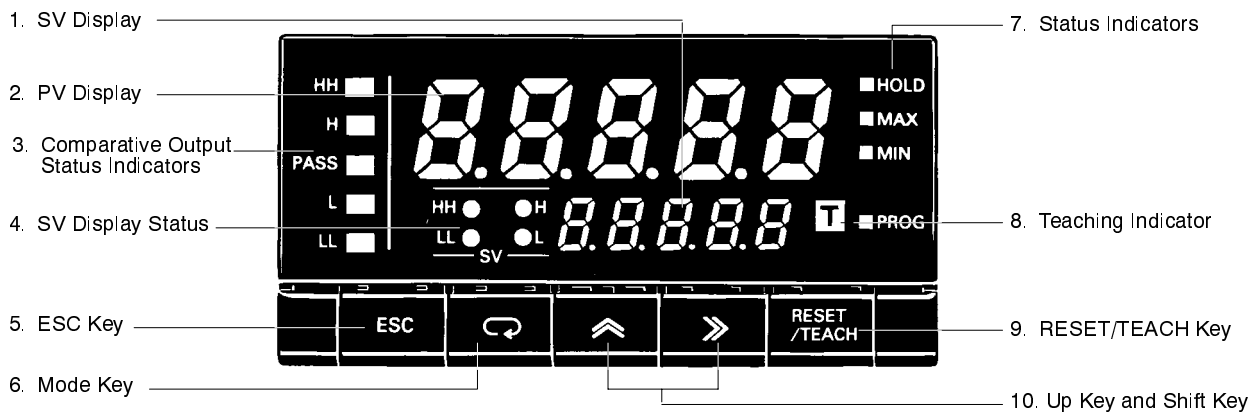

Name	Functions
1. SV display	Displays the set value or parameter. Available for Set Value LED Models only.
2. PV display	Displays the process value in addition to the max/min value or parameter.
3. Comparative output status indicators	Displays the status of comparative output.
4. SV display status	Indicates which comparative set value is currently on the SV display.
5. ESC Key	Used to return to the RUN mode from the Setting, Protect, or Maintenance mode. The process value, maximum value, or minimum value to be displayed can be selected.
6. Mode Key	Used to enter the Setting mode. Used to allow the PV display to indicate set values sequentially. Available for Basic Models only. Used to indicate set values sequentially on the SV display. Available for Set Value LED Models only.
7. Status indicator	HOLD: Lit when HOLD input is ON. MAX: Lit when the maximum value is indicated on the PV display. MIN: Lit when the minimum value is indicated on the PV display. PROG: Lit or flashes while parameters are being set.
8. Teaching indicator	Lit when the teaching function is enabled and flashes when the Intelligent Signal Processor is in teaching operation.
9. RESET/TEACH Key	The measurement data, maximum value and minimum value are reset by pressing this key. Teaching is available when the teaching function is enabled.
10. Up Key and Shift Key	The digit being set is scrolled by pressing the shift key. The set value increases by one whenever the up key is pressed.

Operation

SETTING PROCEDURES

The K3NP has four modes: RUN mode for normal operations, Setting mode for initial parameter input, Protect mode for lock-out configuration, and Maintenance mode for initializing set values. The parameters that are accessible on any individual K3NP will vary depending on the output board installed. Refer to the *K3NP Operation Manual* for details.

- RUN Mode:** Remains in this mode under normal operation.
The process value or the max./min. value can be monitored.
Using the front panel keys, the comparative set value can be changed and max./min. values reset can be performed.
- Setting Mode:** Used for making initial settings.
Includes settings for four menus (Set value (*S₀SET*), prescaling (*P₅CL*), setup (*SETUP*), option (*OPT*)) and the output test.
- Protect Mode:** Used for locking the front key operation or parameter changes.
- Maintenance Mode:** Used for initializing set values.

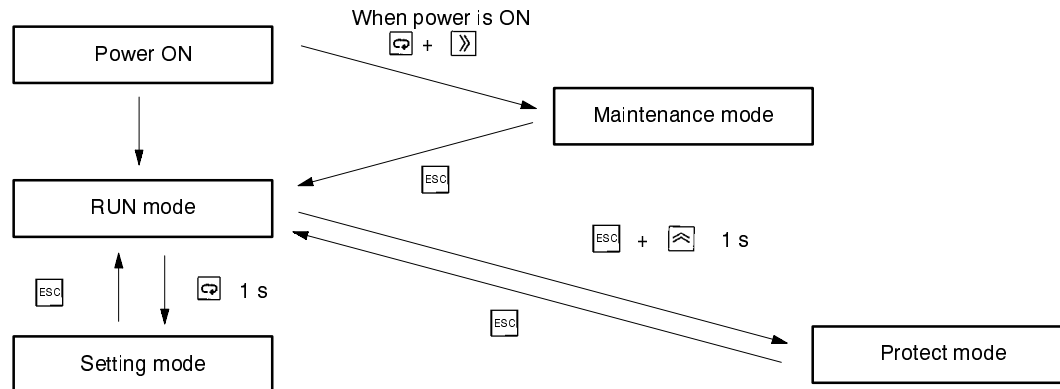

S₀SET - Program set values

- S₀BRN^H* Select bank no. of set values
- S₀HH* Enter set value HH of bank 1
- S₀L^H* Enter set value H of bank 1
- S₀L^L* Enter set value L of bank 1
- S₀LL* Enter set value LL of bank 1

Note: The above is an example when the bank number is set to 1.

P₅CL - Display prescaling

- P₅BRN^H* Select bank no. of prescale values
- P₅IR^H* Set the mantissa (X) of the prescale value of input A
- P₅IR^L* Set the exponent (Y) of the prescale value of input A
- dECP.1* Select decimal point

Note: The above is an example when the bank number is set to 1.

SETUP - Program operating mode/input sensor/serial communications

- FUnC* Specify operating mode
- cnA* Select a sensor type of input A
- cnB* Select a sensor type of input B
- tCnE* Select the display time unit
- U-nō* Enter the unit no. for the host
- bPS* Select the baud rate
- LEn* Select the word bit length
- Sbc^t* Select the stop bits
- P-r^ty* Select the parity bits

OPT - Supplementary settings related to display or control

- C-OUT* Select the output pattern
- LSET.H* Enter the upper limit (H) of linear output range
- LSET.L* Enter the lower limit (L) of linear output range
- r-L* Select the remote/local programming

tESE - Generating simulated input for testing the output function

Prōt - Program lock-out configuration

- ALL* Enable all key protection
- S₀SET* Enable set value change prohibition
- rESEt* Enable prohibition of all the measurement data and max./min. value reset using the front panel keys
- SECr* Specify the menus to be protected against setting in the Setting mode

PARAMETERS

Output Pattern Selection $\overline{L-OUT}$

The patterns of comparative output are selectable according to the level change. Select the pattern according to the application.

Standard Output

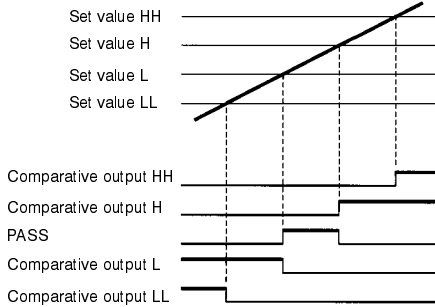

Zone Output

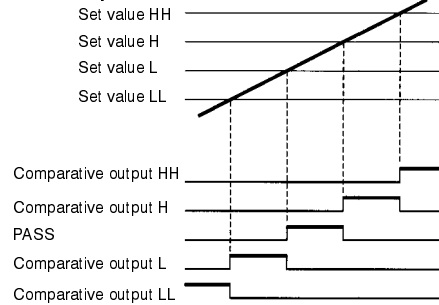

Level Output

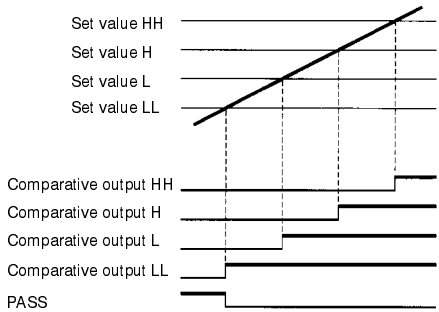

Note: The following setting conditions must be satisfied, otherwise no zone output will turn ON correctly.
 $LL < L < H < HH$

Linear Output Range $LSET$

A linear output range can be set as required. A value corresponding to the maximum output value and that corresponding to the minimum output value can be set.

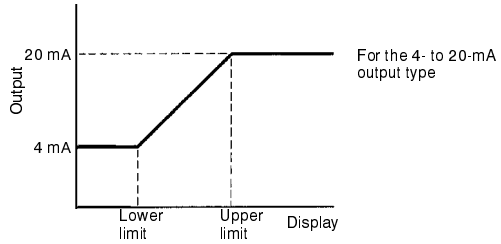

Remote/Local Selection $r-L$

Select remote programming when performing all settings through the host devices and select local programming when performing settings through key operation.

Prescaling

Input pulses are converted into desired values.

TERMINAL ARRANGEMENT

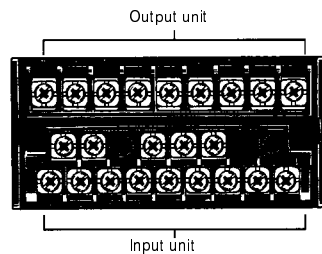

Terminal Numbers

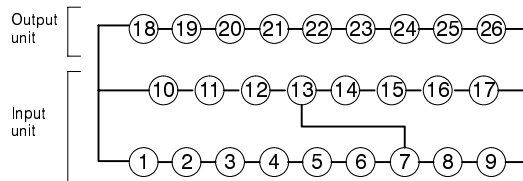

Note: Terminals 7 to 13 are connected internally.

INPUT UNIT

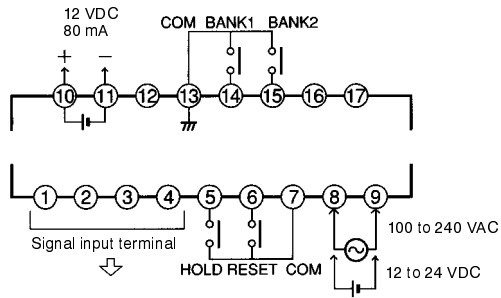

K3NP-NB
(NPN input/voltage pulse input)

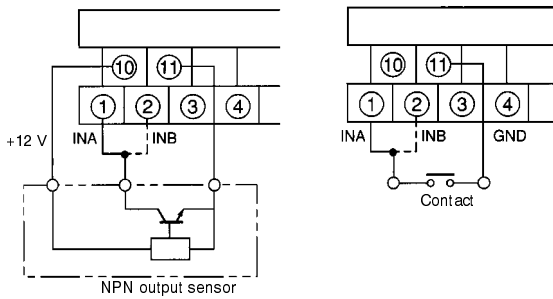

K3NP-PB (PNP input)

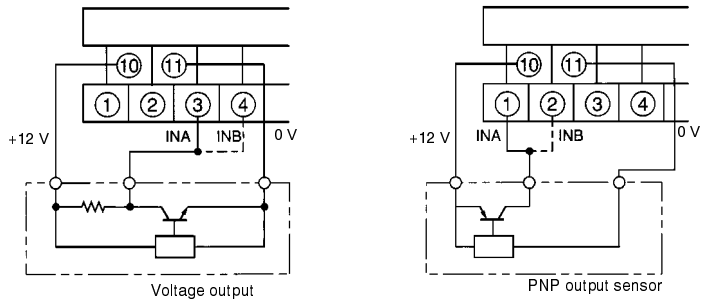

When inputting the external control signals through the open collector:

Transistor Inputs:

ON: Residual voltage must be 3 V max.

OFF: Leakage current must be 1.5 mA max.

The switching capacity must be 20 mA or greater.

When the external signal input is short-circuited, a voltage of approximately 5 V will be applied to between the terminals 5 to 7 and the COM terminal, and a current of approximately 18 mA (nominal value) will flow.

OUTPUT BOARDS

K31-C1: Relay (3 Outputs)

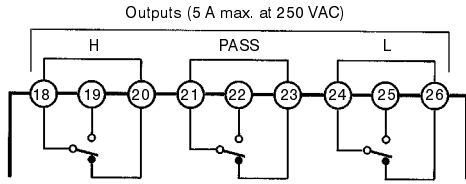

K31-C2: Relay (5 Outputs)

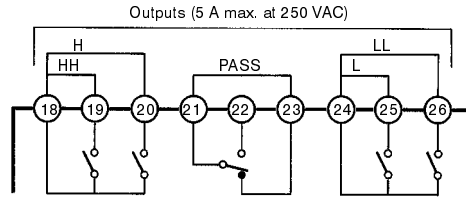

K31-C5: Relay (5 Outputs)

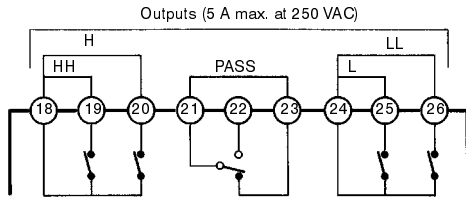

K31-T1: Transistor (NPN Open Collector)

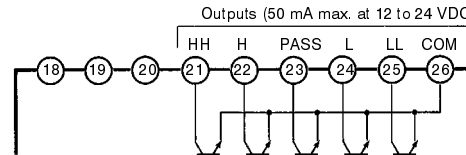

K31-T2: Transistor (PNP Open Collector)

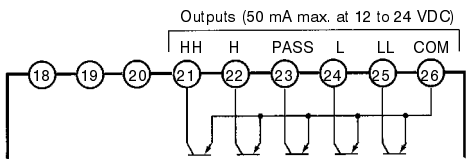

K31-B2, -B4: BCD (NPN Open Collector)

(Terminals 32 to 36 are provided only on K31-B4.)

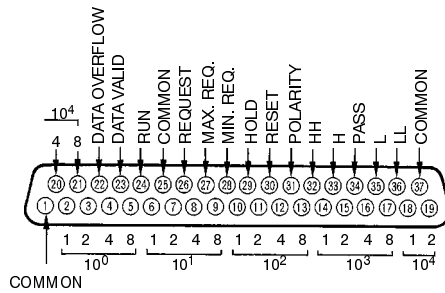

K31-L1, -L2, -L3, -L4, -L5, -L6, -L7, -L8, -L9, -L10: Linear

(Terminals 21 to 26 are provided only on K31-L4, -L5, -L6, -L9, -L10.)

- L1, L4: 4 to 20 mA
- L2, L5: 1 to 5 V
- L3, L6: 1 mV/10 digit
- L7, L9: 0 to 5 VDC
- L8, L10: 0 to 10 VDC

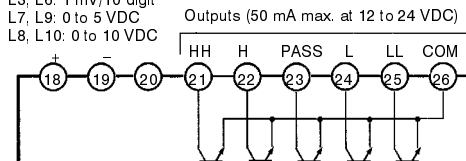

K31-FLK1: RS-232C

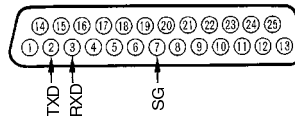

K31-FLK2, -FLK5: RS-485

(Terminals 21 to 26 are provided only on K31-FLK5.)

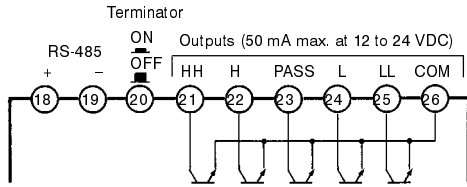

- D-sub 37P Connectors for BCD output (order separately)
Plug: XM2A-3701
Hood: XM2S-3711
- D-sub 25P connectors for RS-232C output (K31-FLK1) (order separately)
Plug: XM2A-2501
Hood: XM2S-2511
- D-sub 9P connectors for RS-422 output (K31-FLK3 and K31-FLK6) (order separately)
Plug: XM2A-0901
Hood: XM2S-0911
- D-sub 9P connectors for RS-232C output (K31-FLK4) (order separately)
Plug: XM2D-0901
Hood: XM2D-0911

K31-FLK3, -FLK6: RS-422

(The right-hand side connector is provided only on K31-FLK6.)

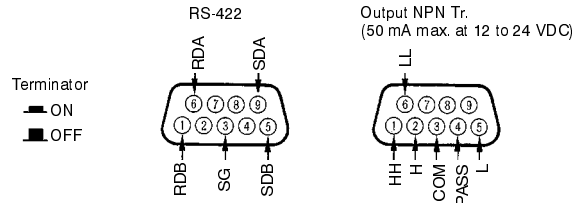

K31-FLK4: RS-232C + Transistor (NPN Open Collector)

Output NPN Tr. (50 mA max. at 12 to 24 VDC)

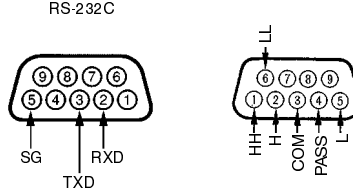

BCD OUTPUT TIMING CHART

A request signal from an external device (such as a programmable controller) is required to read BCD data.

Single Sampling Data Output

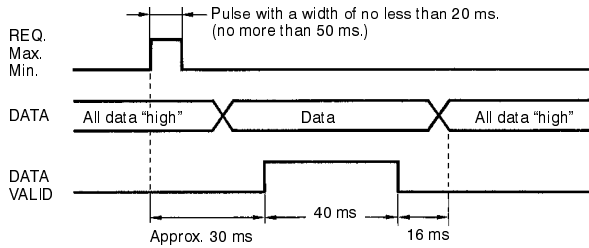

Approximately 30 ms after the REQ signal rises, a sample is taken and the DATA VALID signal is output. Read the data when the DATA VALID signal is ON.

The DATA VALID signal will turn OFF in 40 ms, and then in 16 ms, the data will go OFF.

Models with a BCD output have an open collector output configuration so that wired-OR connection is possible.

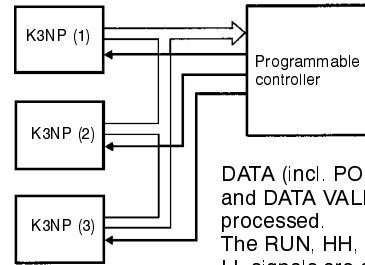

DATA (incl. POL and OVER) and DATA VALID are wired-OR processed. The RUN, HH, H, PASS, L, and LL signals are always output regardless of the status of the REQ signal. Do not OR-wire these signals.

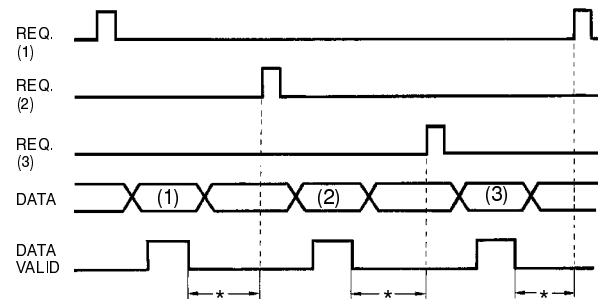

*The period between the DATA VALID signal and the REQ signal should be no less than 20 ms max.

Continuous Data Output

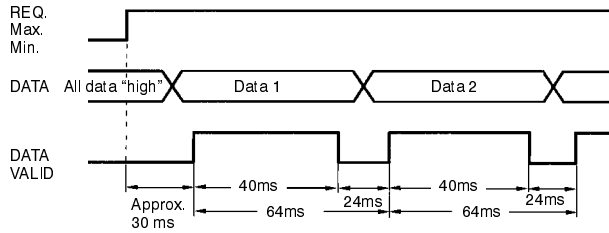

The K3NP outputs each measurement at an interval of 64 ms when a REQ signal is ON continuously. If the HOLD signal is ON at the moment the DATA output is switched from Data 1 to Data 2 or vice versa, the output BCD data will be either Data 1 or Data 2 according to the timing of the HOLD signal. However, output data will never be low.

OUTPUT OPERATION TIMING IN RUN MODE (RELAY OR TRANSISTOR OUTPUTS)

The following timing chart is for a 5-comparative output board when the standard output pattern is selected.

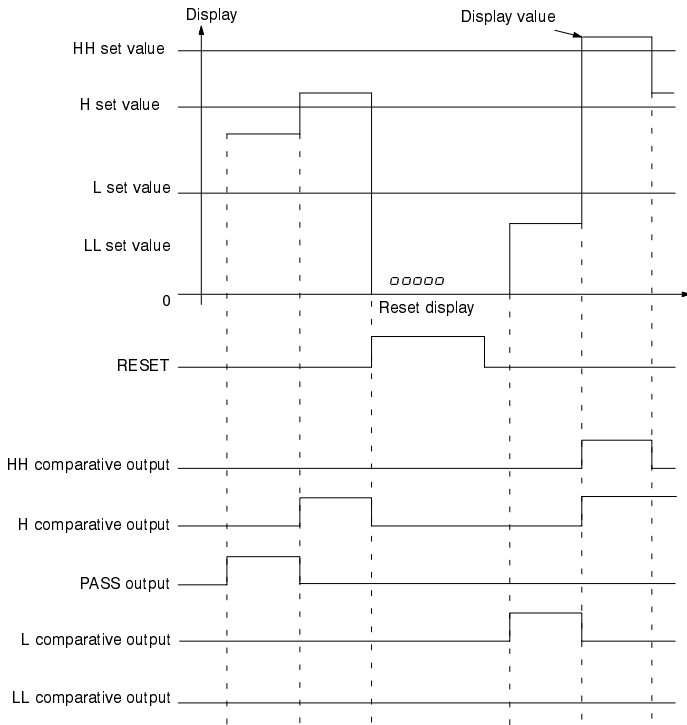

Note: Because measuring is not continuous, the comparative output turns ON when the measuring operation is completed.

OPERATING MODES

The K3NP provides 6 operating modes for converting input pulses to display values. The mode can be selected via key operations on the front panel.

The time between pulses or the pulse ON time is measured using the internal system clock, and time and other display values are calculated accordingly.

Example: F1 Passing Speed

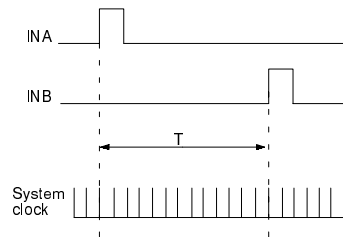

Operating mode no.	Use
01	Passing speed
02	Cycle
03	Time difference
04	Elapsed time
05	Length measurement
06	Interval

The time (T) between the INA pulse and the INB pulse is counted using the internal system clock.

If the count between the pulses is 100,000, then

$$T = \text{System clock pulse (0.5 } \mu\text{s)} \times 100,000 = 0.05 \text{ s}$$

For operating mode 1 (Passing Speed), $1/T \times 60$ (m/min) is used. The display value is thus $1/0.05 \text{ s} \times 60$, or 1,200 (m/min)

Operating Mode 1: Passing Speed

The inverse of the time between input A coming ON and input B coming ON is multiplied by 60 and displayed.

A 20-ms recovery time (T_R) is required at the start of each measurement operation.

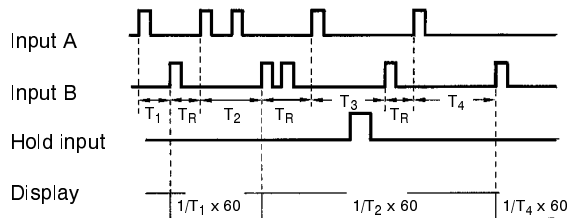

Units: mm/s; m/s; m/min; km/h; etc.

Application Example

Measuring the speed of workpieces between points A and B

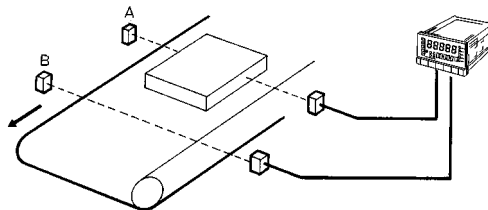

Operating Mode 2: Cycle

The period (T) of input A is displayed

The K3NP is in measuring operation during every other period of input A ON.

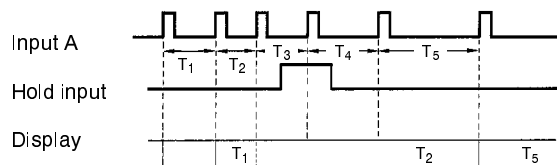

Units: s; min; h, min, s, 1/10 s; etc.

Application Example

Measuring the rate at which parts are fed

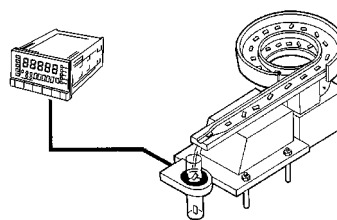

Operating Mode 3: Time Difference

The time between input A turning ON and input B turning ON is displayed.

A 20-ms recovery time (T_R) is required at the start of each measurement operation.

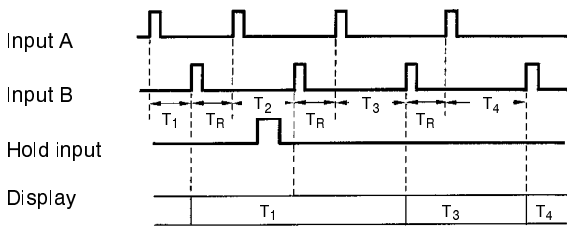

Units: s; min; h, min, s; min, s, 1/10 s; etc

Application Example

Measuring the time required for workpieces to pass from point A to point B

Can be used with prescaling to measure lengths of steps

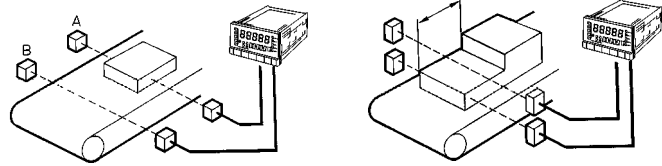

Operating Mode 4: Elapsed Time

The time (T) that input A is ON is displayed.

A 20-ms recovery time (T_R) is required at the start of each measurement operation.

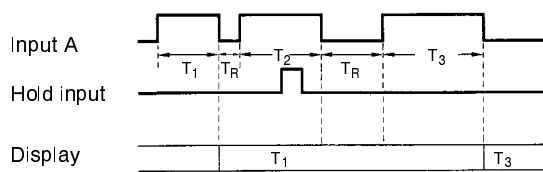

Units: s; min; h, min, s; min, s, 1/10 s; etc.

Application Example

Monitoring the time that a press is activated

Controlling the time that a valve is open

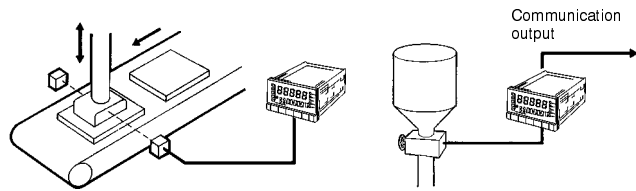

Operating Mode 5: Length Measurement

The number of pulses received on input A while input B is ON is displayed.

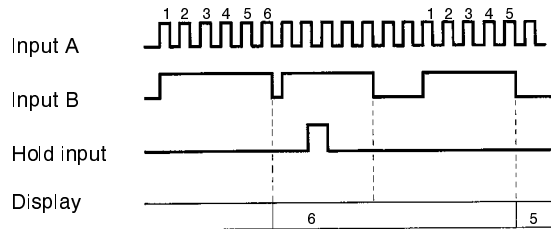

Units: mm; cm; m; etc.

Application Example

Measuring workpiece length

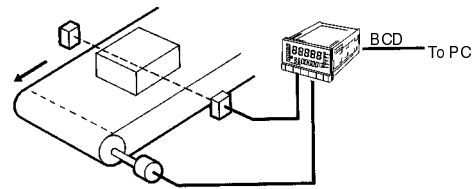

Operating Mode 6: Interval

The number of pulses received on input A between two pulses on input B is displayed.

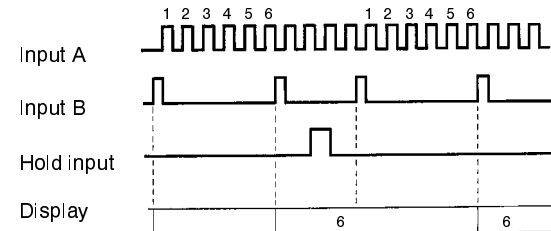

Units: mm; cm; m; etc.

Application Example

Measuring slot spacing

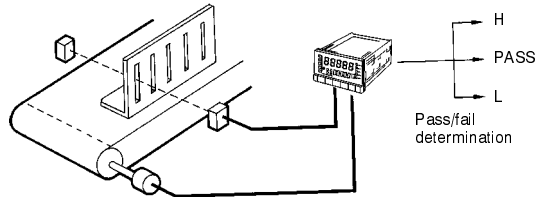

■ BLOCK DIAGRAM

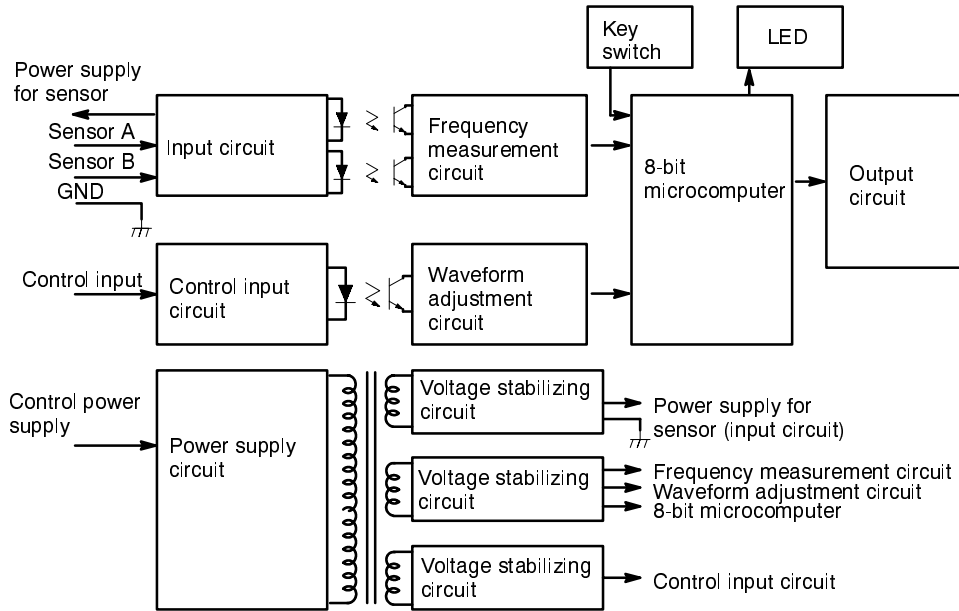

Dimensions

Unit: mm (inch)

■ K3NP

PV Display

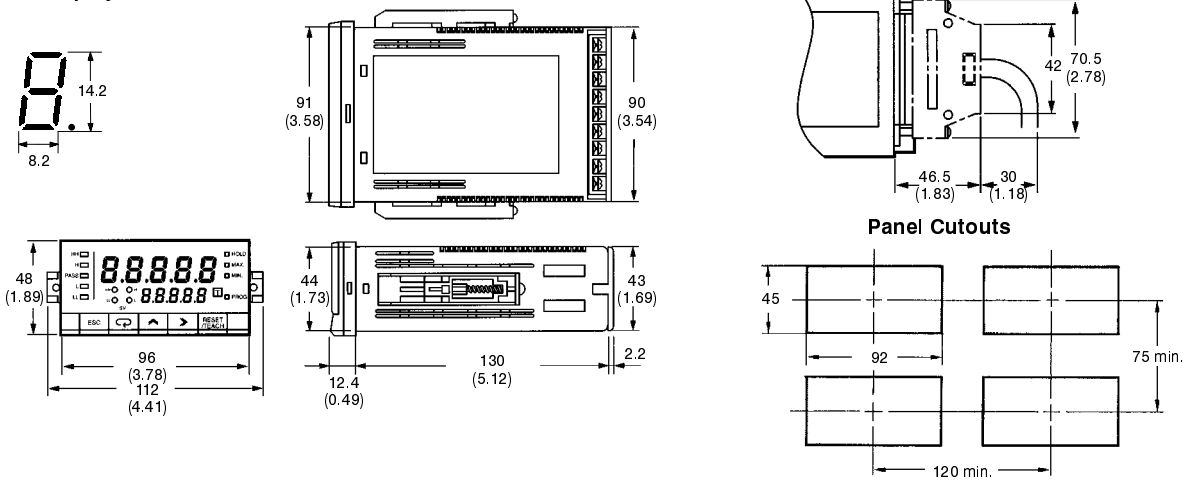

Installation

EXAMPLE OF CONNECTION TO PROGRAMMABLE CONTROLLER

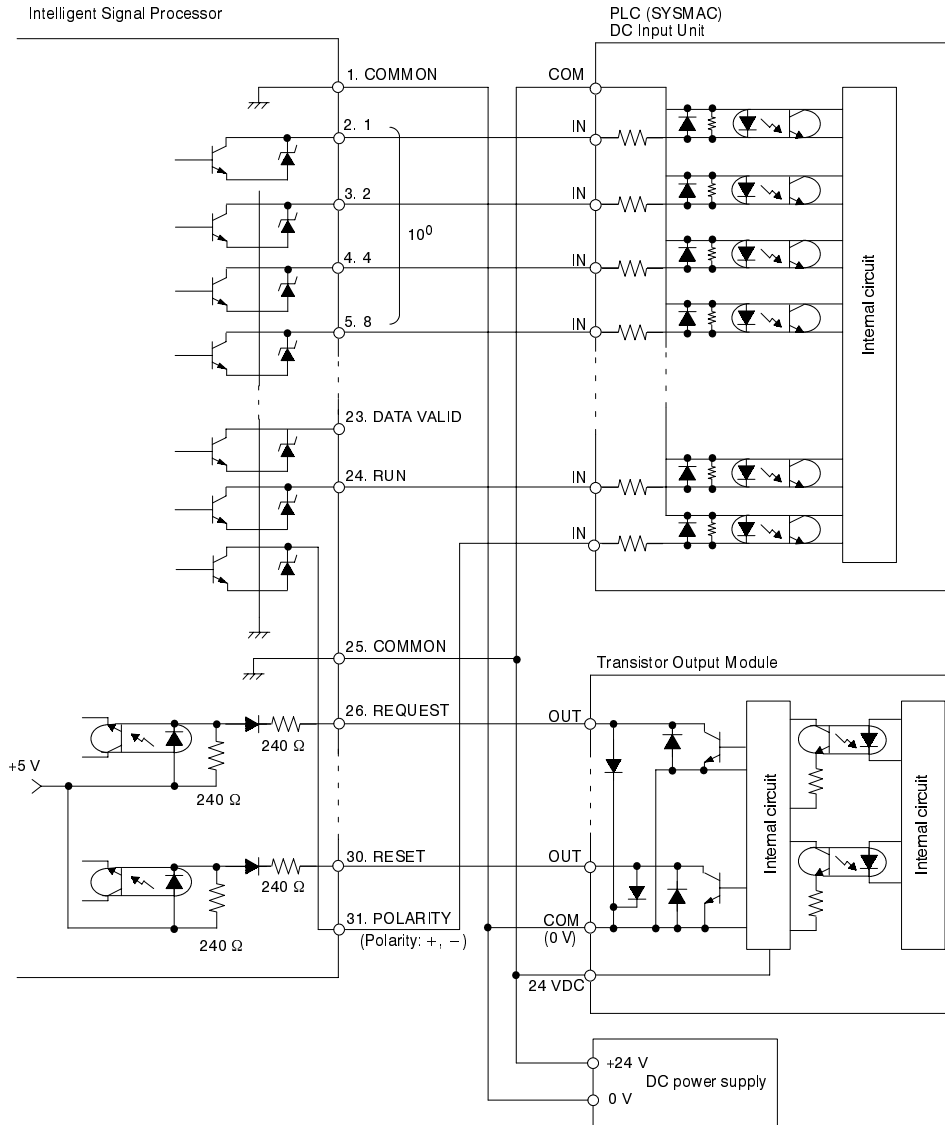

Precautions

AVOID ELECTRIC SHOCK

- Do not touch any terminals.
- Do not disassemble the product or touch the internal components of the product.
- Be sure that the power supply voltage is within the rated range.
- Do not use the Intelligent Signal Processor in locations with flammable gas or combustible substances.
- Be sure to wire the terminals correctly by checking the terminal names.
- Be sure that the terminal screws are tightened securely when wiring.

■ MOUNTING

- Recommended panel thickness is 1 to 3.2 mm.

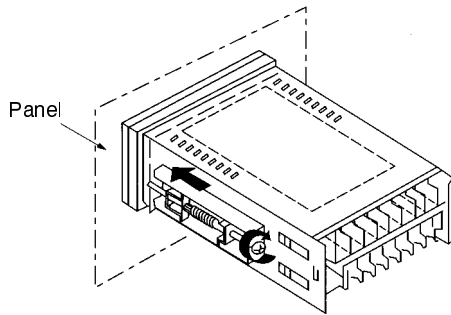

- Attach the mounting bracket on the left and right sides of the Intelligent Signal Processor (as shown in the illustration above). Gradually tighten each screw evenly, balancing the tightening force until the ratchet starts to slip.
- Mount the Processor horizontally.
- Never use the Processor in locations where corrosive gas (particularly sulfur or ammonia gas) is generated.
- Avoid use of the Processor in a location subject to severe shock or vibration, excessive dust, or excessive moisture.
- Select an indoor mounting location where the Intelligent Signal Processor is at the rated temperature and humidity and free from direct sunlight.
- Separate the Processor from machines generating high-frequency noise, such as high-frequency welding machines and high-frequency sewing machines.

■ OPERATION

- A Processor model with a relay contact or transistor output board may not output any alarm signal normally if the model has an error. It is recommended that an independent alarm device be connected to the model.
- The parameters are factory-set for normal operation. The settings of the parameters may be changed according to the application.

■ UNIT LABEL (ATTACHED)

No product is shipped with the unit label attached. Select a unit label from the sheet provided and attach it to the Processor.

A	Δ	mA	mΔ	V
∇	mV	m∇	W	KW
VA	KVA	var	Kvar	Ω
°C	°F	K	Hz	rpm
m	mm	cm	μm	Km
ℓ	Kℓ	t	TON	ℓx
m³	cm³	mm³	Kg	g
mg	Kg/m³	g/cm³	m³/Kg	m/s²
G	N	mmHg	mmH₂O	Kgf/cm²
Kgf/mm²	J	KJ	Kgf-cm	gf-cm
PS	hp	cal	Kcal	Kg/h
t/h	Kg/s	m³/min	m³/h	m³/s
ℓ/s	ℓ/min	ℓ/h	m/min	mm/s
m/s	%	dB	φ-mm	SCCM
sec	ms	min	counts	×10
×100	×1000	pH	ppm	pcs
deg	cP	cSt	KΩ	MΩ
KHZ	rps			
kV	s	m²	cm	rad
S	S	L	kL	L/s
L/min	L/h	kN	mN	Pa
kPa	mPa	N·m	kN·m	mN·m
kg·m²	lx	cPs	°	rPh
r/s	r/min	r/h	min⁻¹	h⁻¹
				h.min.s
min.s.10s			OMRON	

OMRON[®]
OMRON ELECTRONICS, INC.
 One East Commerce Drive
 Schaumburg, IL 60173
1-800-55-OMRON

OMRON CANADA, INC.
 885 Milner Avenue
 Scarborough, Ontario M1B 5V8
416-286-6465