

**NSH Series**  
**NSH5-SQR00B-V2**  
**NSH5-SQG00B-V2**

# **Hand-held Programmable Terminal**

# **OPERATION MANUAL**

**OMRON**

**NSH Series**

**NSH5-SQR00B-V2**

**NSH5-SQG00B-V2**

**Hand-held Programmable Terminal**

**Operation Manual**

*Revised July 2007*





## **Notice:**

OMRON products are manufactured for use according to proper procedures by a qualified operator and only for the purposes described in this manual.

The following conventions are used to indicate and classify precautions in this manual. Always heed the information provided with them. Failure to heed precautions can result in injury to people or damage to property.

 **DANGER** Indicates an imminently hazardous situation which, if not avoided, will result in death or serious injury. Additionally, there may be severe property damage.

 **WARNING** Indicates a potentially hazardous situation which, if not avoided, could result in death or serious injury. Additionally, there may be severe property damage.

 **Caution** Indicates a potentially hazardous situation which, if not avoided, may result in minor or moderate injury, or property damage.

## **OMRON Product References**

All OMRON products are capitalized in this manual. The word “Unit” is also capitalized when it refers to an OMRON product, regardless of whether or not it appears in the proper name of the product.

The abbreviation “Ch,” which appears in some displays and on some OMRON products, often means “word” and is abbreviated “Wd” in documentation in this sense.

The abbreviation “PLC” means Programmable Controller. “PC” is used, however, in some Programming Device displays to mean Programmable Controller.

## **Visual Aids**

The following headings appear in the left column of the manual to help you locate different types of information.

**Note** Indicates information of particular interest for efficient and convenient operation of the product.

**1,2,3...** 1. Indicates lists of one sort or another, such as procedures, checklists, etc.

## **Important**

The LCD panel is created using extremely advanced technology, but there may still be some defective pixels, such as pixels that will not light or that are lit continuously. These are characteristic of LCDs and do not indicate a fault. Although manufacturing processes are managed to eliminate defective pixels as much as possible, eliminating all of them is not possible using currently available technology.

The display device may be changed to make improvements without prior notice.

## **Trademarks**

Windows is a registered trademark of Microsoft Corporation in the United States and other countries. Other brand and product names are trademarks or registered trademarks of their respective owners.

**© OMRON, 2005**

All rights reserved. No part of this publication may be reproduced, stored in a retrieval system, or transmitted, in any form, or by any means, mechanical, electronic, photocopying, recording, or otherwise, without the prior written permission of OMRON.

No patent liability is assumed with respect to the use of the information contained herein. Moreover, because OMRON is constantly striving to improve its high-quality products, the information contained in this manual is subject to change without notice. Every precaution has been taken in the preparation of this manual. Nevertheless, OMRON assumes no responsibility for errors or omissions. Neither is any liability assumed for damages resulting from the use of the information contained in this publication.

# TABLE OF CONTENTS

<b>PRECAUTIONS</b> .....	<b>xvii</b>
1 Intended Audience .....	xviii
2 General Precautions .....	xviii
3 Safety Precautions .....	xviii
4 Precautions for Safe Use .....	xix
5 Operating Environment Precautions .....	xxi
6 EC Directives .....	xxii
<b>SECTION 1</b>	
<b>Introduction</b> .....	<b>1</b>
1-1 Overview .....	2
1-2 Nomenclature and Functions .....	8
1-3 Special Cable Specifications .....	10
<b>SECTION 2</b>	
<b>Grounding and Connections</b> .....	<b>25</b>
2-1 Installation Environment .....	26
2-2 Power Supply and FG Wiring .....	26
2-3 Connecting the Special Cable .....	28
2-4 Attaching the Hand Strap .....	32
2-5 Installing the Mounting Bracket .....	33
<b>SECTION 3</b>	
<b>Functions</b> .....	<b>37</b>
3-1 Creating Screen Projects .....	38
3-2 Emergency Stop Switch .....	38
3-3 Enabling Switch .....	40
3-4 Function Switches .....	41
3-5 Memory Cards .....	42
3-6 USB Port .....	48
3-7 Screen Saver Prohibit Function .....	48
3-8 Usable Host Connection Methods .....	49
3-9 Station Detection Function .....	50
<b>SECTION 4</b>	
<b>Connecting to the Removable Box</b> .....	<b>53</b>
4-1 Overview of Removable Box .....	54
4-2 Nomenclature and Functions .....	54
4-3 Switch Settings .....	56
4-4 Installation .....	58
4-5 Connection Method .....	60

# TABLE OF CONTENTS

## SECTION 5

### **Inspection and Maintenance . . . . . 65**

5-1	Maintenance . . . . .	66
5-2	Inspection and Cleaning . . . . .	67
5-3	Error Message Tables . . . . .	69
5-4	Precautions When Replacing the PT . . . . .	69

### **Appendices**

A	General Specifications . . . . .	71
B	Dimensions . . . . .	77
C	Types of Memory . . . . .	79
D	Comparison of Functions with NS-Designer . . . . .	81
E	Recommended Enabling Circuits . . . . .	85
F	Removable Box Application Examples . . . . .	91

### **Revision History . . . . . 101**

## ***About this Manual:***

This manual describes the installation and operation of the NSH5 Programmable Terminal and includes the sections described below.

The NSH5 Programmable Terminal is a Hand-held Programmable Terminal manufactured by OMRON that provides a touch panel and safety switches.

Please read this manual carefully and be sure you understand the information provided before attempting to install or operate the NSH5 Programmable Terminal.

Use this manual together with the NS-series PT manual, and be sure to read the precautions provided in the following section.

**Precautions** provides general precautions for using the NSH5 Programmable Terminal and related devices.

**Section 1** describes the features, nomenclature, and functions of the NSH5 Programmable Terminal for first-time users.

**Section 2** describes wiring and grounding the power supply and how to connect the NSH5 Programmable Terminal using the Special Cable.

**Section 3** describes the functions that have been expanded or newly added to the NSH5 Programmable Terminal.

**Section 4** describes the Removable Box, which is connected to the NSH5.

**Section 5** describes inspection and maintenance and the contents of error messages for the NSH5 Programmable Terminal.

The **Appendices** provide specifications, dimensions, memory reference tables, and recommended enabling circuits

 **WARNING** Failure to read and understand the information provided in this manual may result in personal injury or death, damage to the product, or product failure. Please read each section in its entirety and be sure you understand the information provided in the section and related sections before attempting any of the procedures or operations given.



# Related Manuals

Related manuals are listed below.

The □ symbol at the end of the catalog number is the revision code.

## Operating the CX-Designer

- CX-Designer Operation Manual (V088-E1-□)

This manual describes the installation method, basic operating procedures, and the user interface of the CX-Designer. Typical features and applications methods are also described. Operating methods, procedures, and settings for the CX-Designer can be displayed on the screen using online help. Online help can be referred to for normal operations.

Refer to the following manuals for detailed information of the operation of NS-series PTs.

## Checking NS-series PT Functions, Applications, and Troubleshooting

- NS-series Programmable Terminal Programming Manual (V073-E1-□)

This manual describes functions and applications of NS-series PTs. Also included are descriptions of remedies for faults that occur in NS-series PTs.

## Checking NS-series PT Functions, Operation, and Restrictions

- NS-series Programmable Terminal Programming Manual (V083-E1-□)

This manual is for NS V1/V2-series PTs (NS12-V1, NS10-V1, NS8-V1, NS5-V1, NS5-V2).

The manual describes installation, connections, general specifications, and hardware for NS-series PTs.

- NS-series Programmable Terminal Setup Manual (V072-E1-□)

This manual is for NS-series PTs (NS12, NS10, NS7).

## Checking PLC Functions and Operation

- Relevant PLC User's Manual

When information on PLC operation and functions is required, refer to the user's manuals for the relevant PLC, Special I/O Unit, CPU Bus Unit, or Communications Unit.

# ***Terminology***

The following terminology is used in this manual.

NSH5	Indicates products in the OMRON NSH5 Series of Programmable Terminals.
PLC	Indicates an OMRON Programmable Controller.
Host	Indicates the PLC or IBM PC/AT or compatible computer functioning as the control device and interfaced with the NS-series PT.
CX-Designer	Indicates the OMRON CX-Designer (NS-CXDC1-V□). The CX-Designer is a Support Software application used to create screen data for NS-series PTs.



## ***Read and Understand this Manual***

Please read and understand this manual before using the product. Please consult your OMRON representative if you have any questions or comments.

## ***Warranty and Limitations of Liability***

### ***WARRANTY***

OMRON's exclusive warranty is that the products are free from defects in materials and workmanship for a period of one year (or other period if specified) from date of sale by OMRON.

OMRON MAKES NO WARRANTY OR REPRESENTATION, EXPRESS OR IMPLIED, REGARDING NON-INFRINGEMENT, MERCHANTABILITY, OR FITNESS FOR PARTICULAR PURPOSE OF THE PRODUCTS. ANY BUYER OR USER ACKNOWLEDGES THAT THE BUYER OR USER ALONE HAS DETERMINED THAT THE PRODUCTS WILL SUITABLY MEET THE REQUIREMENTS OF THEIR INTENDED USE. OMRON DISCLAIMS ALL OTHER WARRANTIES, EXPRESS OR IMPLIED.

### ***LIMITATIONS OF LIABILITY***

OMRON SHALL NOT BE RESPONSIBLE FOR SPECIAL, INDIRECT, OR CONSEQUENTIAL DAMAGES, LOSS OF PROFITS OR COMMERCIAL LOSS IN ANY WAY CONNECTED WITH THE PRODUCTS, WHETHER SUCH CLAIM IS BASED ON CONTRACT, WARRANTY, NEGLIGENCE, OR STRICT LIABILITY.

In no event shall the responsibility of OMRON for any act exceed the individual price of the product on which liability is asserted.

IN NO EVENT SHALL OMRON BE RESPONSIBLE FOR WARRANTY, REPAIR, OR OTHER CLAIMS REGARDING THE PRODUCTS UNLESS OMRON'S ANALYSIS CONFIRMS THAT THE PRODUCTS WERE PROPERLY HANDLED, STORED, INSTALLED, AND MAINTAINED AND NOT SUBJECT TO CONTAMINATION, ABUSE, MISUSE, OR INAPPROPRIATE MODIFICATION OR REPAIR.

# ***Application Considerations***

## ***SUITABILITY FOR USE***

OMRON shall not be responsible for conformity with any standards, codes, or regulations that apply to the combination of products in the customer's application or use of the products.

At the customer's request, OMRON will provide applicable third party certification documents identifying ratings and limitations of use that apply to the products. This information by itself is not sufficient for a complete determination of the suitability of the products in combination with the end product, machine, system, or other application or use.

The following are some examples of applications for which particular attention must be given. This is not intended to be an exhaustive list of all possible uses of the products, nor is it intended to imply that the uses listed may be suitable for the products:

- Outdoor use, uses involving potential chemical contamination or electrical interference, or conditions or uses not described in this manual.
- Nuclear energy control systems, combustion systems, railroad systems, aviation systems, medical equipment, amusement machines, vehicles, safety equipment, and installations subject to separate industry or government regulations.
- Systems, machines, and equipment that could present a risk to life or property.

Please know and observe all prohibitions of use applicable to the products.

**NEVER USE THE PRODUCTS FOR AN APPLICATION INVOLVING SERIOUS RISK TO LIFE OR PROPERTY WITHOUT ENSURING THAT THE SYSTEM AS A WHOLE HAS BEEN DESIGNED TO ADDRESS THE RISKS, AND THAT THE OMRON PRODUCTS ARE PROPERLY RATED AND INSTALLED FOR THE INTENDED USE WITHIN THE OVERALL EQUIPMENT OR SYSTEM.**

## ***PROGRAMMABLE PRODUCTS***

OMRON shall not be responsible for the user's programming of a programmable product, or any consequence thereof.

## ***Disclaimers***

### ***CHANGE IN SPECIFICATIONS***

Product specifications and accessories may be changed at any time based on improvements and other reasons.

It is our practice to change model numbers when published ratings or features are changed, or when significant construction changes are made. However, some specifications of the products may be changed without any notice. When in doubt, special model numbers may be assigned to fix or establish key specifications for your application on your request. Please consult with your OMRON representative at any time to confirm actual specifications of purchased products.

### ***DIMENSIONS AND WEIGHTS***

Dimensions and weights are nominal and are not to be used for manufacturing purposes, even when tolerances are shown.

### ***PERFORMANCE DATA***

Performance data given in this manual is provided as a guide for the user in determining suitability and does not constitute a warranty. It may represent the result of OMRON's test conditions, and the users must correlate it to actual application requirements. Actual performance is subject to the OMRON Warranty and Limitations of Liability.

### ***ERRORS AND OMISSIONS***

The information in this manual has been carefully checked and is believed to be accurate; however, no responsibility is assumed for clerical, typographical, or proofreading errors, or omissions.



# PRECAUTIONS

This section provides general precautions for using the NSH-series Programmable Terminal (PT).

**The information contained in this section is important for the safe and reliable application of the PT. You must read this section and understand the information contained before attempting to set up or operate an NSH-series PT.**

1	Intended Audience .....	xviii
2	General Precautions .....	xviii
3	Safety Precautions .....	xviii
4	Precautions for Safe Use .....	xix
5	Operating Environment Precautions .....	xxi
6	EC Directives .....	xxii



## 1 Intended Audience

This manual is intended for the following personnel, who must also have knowledge of electrical systems (an electrical engineer or the equivalent).

- Personnel in charge of introducing FA systems into production facilities.
- Personnel in charge of designing FA systems.
- Personnel in charge of installing and connecting FA systems.
- Personnel in charge of managing FA systems and facilities.

## 2 General Precautions

The user must operate the product according to the performance specifications described in the operation manuals.

Before using the product under conditions which are not described in the manual or applying the product to nuclear control systems, railroad systems, aviation systems, vehicles, combustion systems, medical equipment, amusement machines, safety equipment, and other systems, machines and equipment that may have a serious influence on lives and property if used improperly, consult your OMRON representative.



Make sure that the ratings and performance characteristics of the product are sufficient for the systems, machines, and equipment, and be sure to provide the systems, machines, and equipment with double safety mechanisms.

This manual provides information for using the PT. Be sure to read this manual before attempting to use the software and keep this manual close at hand for reference during operation.

 **WARNING** It is extremely important that PTs and related devices be used for the specified purpose and under the specified conditions, especially in applications that can directly or indirectly affect human life. You must consult with your OMRON representative before applying PTs to the above-mentioned applications.

## 3 Safety Precautions

Read these safety precautions carefully and make sure you understand them before using the PT so that you can use it safely and correctly.

 <b>WARNING</b>	
Do not attempt to take the PT apart and do not touch any internal parts while the power is being supplied. Doing either of these may result in electrical shock.	

 **WARNING**

- Always ensure that personnel in charge properly perform installation, inspection, and maintenance for the PT. “Personnel in charge” refers to individuals qualified and responsible for ensuring safety during machine design, installation, operation, maintenance, and disposal.
- Ensure that installation and post-installation checks are performed by personnel in charge who possess a thorough understanding of the machinery to be installed.
- Do not attempt to disassemble, repair, or modify the PT. Doing so may impair the safety functions.
- Always connect the emergency stop switch and enabling switch to safety circuits. Serious accidents may occur if connection is made to a PLC and there is a malfunction. When using the function switches or switches on the touch panel, do not create switches that may cause injury or damage property. Install a monitoring circuit or other device in output signals that may result in serious accidents. Construct the system so that switching of important operations is performed in devices outside the PT.
- For devices and components connected to the PT that affect safety, use appropriate products meeting the required safety level and safety category. System safety and the appropriate safety category must be evaluated for the entire system. Consult a certified third-party organization to determine the appropriate safety category.
- It is the user’s responsibility to ensure that system safety adheres to relevant standards.
- Connect the emergency stop switch, and enabling switch on the PT so that they function according to stop category 0 or 1 described in IEC/EN 60204-1.
- Do not operate the PT on the floor or on a tabletop.
- There are two types of switches on the PT, a red one for use as an emergency stop switch, and a gray one for use as a stop switch. Use each of these for its intended purpose. When using a PT with a red emergency stop switch, attach the cable from the system securely so it cannot be easily disconnected. When using a PT with a gray stop switch in an application where the PT is detached from the system, make sure that the emergency stop switch and the stop switch can be clearly distinguished.

## 4 Precautions for Safe Use

- When unpacking the PT and peripheral devices, check that they are not damaged. Lightly shake the products to confirm that no abnormal sound is made.
- Use a power supply with the following specifications for the PT, and for supplying power to the emergency stop switch, enabling switch, function switches, and station detection.
  - For compliance with the EC Directives (Low Voltage Directive), use a power supply with reinforced insulation. Reinforced insulation refers to a single insulation method that is capable of providing the same level of protection against electric shock as double insulation.
  - Do not connect the power supply terminals to an AC power source.
  - Do not perform a dielectric strength test.
  - Insert a 3-A fuse immediately after the secondary output from the power supply.
  - Use a DC power supply with minimal voltage fluctuation.  
Rated power supply voltage: 24 VDC (Allowable range: 20.4 to 27.6 VDC), Capacity: 10 W min.

- Always use a Class 2 power supply for compliance with UL standards. A Class 2 power supply refers to one in which the current and voltage levels of the product's secondary output are both limited (100 VA max.), and which has undergone and passed the necessary tests for UL certification.
- Properly ground the PT to prevent malfunction due to noise.
- Never touch the electronic components or patterns on product boards with your bare hands. Touch grounded metal to discharge any static electricity before handling the PT.
- When connecting the cable to the PT, make sure to secure the cable and the PT. Do not pull on the cable with a force greater than 60 N.
- Thoroughly check the wiring before supplying power.
- Turn OFF the power supply to the PT before connecting or disconnecting the cable.
- Be sure to tighten the connector screws after connecting the cable.
- The entire system may fail to operate depending on how the power supply is turned ON or OFF. Follow specified procedures for turning the power supply ON and OFF.
- Thoroughly confirm operation of screen data, macros, and host programming before starting actual use.
- Do not perform the following operations while the Memory Card is being accessed.
  - Turning OFF the power supply to the PT
  - Removing the Memory Card
  - Always follow specified procedures for removing the Memory Card.
- To ensure system safety, incorporate programming at the host to periodically access a RUN signal to confirm that the PT is operating properly.
- Press touch switches with a force of 30 N max.
- Confirm system safety before pressing touch switches.
- Use caution when pressing touch switches if there is no display shown or if the touch switch backlight is not lit.
- The inputs may not be read properly if touch switches are pressed in rapid succession. Confirm one input before proceeding with the next.
- Confirm that the created screen data is backed up in the CX-Designer before initializing the screen data.
- When changing the password in the System Menu, do not reset the PT or turn OFF the power supply until the write operation has been performed (i.e., until the Write Button returns to normal). The screen may not function if the password is not properly saved.
- When using the device monitor function, thoroughly confirm system safety before performing the following operations.
  - Changing present values for monitor data, timers, or counters
  - Changing the operating mode
  - Force-setting/resetting bits
  - Changing settings for timers or counters
- Never use volatile solvents, such as paint thinner or benzene, or chemical wipes for cleaning.
- Do not attempt to disassemble, repair, or modify the PT.

- When disposing of batteries, comply with all local ordinances that apply to disposal.
- Do not connect a USB connector to any device that is not applicable.
- Before connecting a USB connector to a device, check the external appearance of the device and make sure that the device is free from damage.
- When mounting the battery, be sure to use the correct battery and mount it correctly.
- Dispose of the product and batteries according to local ordinances as they apply. Have qualified specialists properly dispose of used batteries as industrial waste.



「廢電池請回收」

- The backlight in the PT contains mercury. Do not dispose of the PT together with other waste to be sent to a disposal site. Dispose of the PT according to local ordinances as they apply.
- Do not turn OFF the power supply to the PT while downloading or uploading screen data or system programming. The screen data and system programming may become corrupted.
- Secure the PT's cable at the control panel when connecting it to the control panel.
- Be sure not to trip over the cable when moving around while holding the PT.
- Use safety circuits that are capable of detecting shorts in the emergency stop switch and enable switch.
- This is a class A product. In residential areas it may cause radio interference, in which case the user may be required to take adequate measures to reduce interference.

## 5 Operating Environment Precautions

 **Caution** Do not install the control system in the following locations.

- Locations subject to severe changes in temperature
- Locations subject to temperatures or humidity outside the range specified in the specifications
- Locations subject to condensation as a result of severe changes in temperature
- Locations subject water, oil, or chemical spray
- Locations subject to corrosive or flammable gases
- Locations subject to shock or vibration
- Locations outdoors directly subject to wind or rain
- Locations subject to strong ultraviolet light

 **Caution** Take appropriate and sufficient countermeasures when using systems in the following locations:

- Locations subject to static electricity or other forms of noise
- Locations subject to strong electromagnetic fields
- Locations close to power lines
- Locations subject to possible exposure to radioactivity

## 6 EC Directives

### Conforming Directive

The NSH-series PTs conform to the EMC Directive.

### EMC Directive Conformance

OMRON products are designed as electrical devices for use built into other devices or the overall machine. As individual devices, they comply with the related EMC standards (see note) so that they can more easily be built into other devices or the overall machine. The actual products have been checked for conformity to EMC standards. Whether they conform to the standards in the system used by the customer, however, must be checked by the customer.

EMC-related performance of the OMRON devices will vary depending on the configuration, wiring, and other conditions of the equipment or control panel on which the OMRON devices are installed. The customer must, therefore, perform the final check to confirm that devices and the overall machine conform to EMC standards.

**Note** Applicable EMC (Electromagnetic Compatibility) standards are as follows:

EMS (Electromagnetic Susceptibility):	EN 61131-2
EMI (Electromagnetic Interference):	EN 61131-2 (Radiated emission: 10-m regulations)

### Complying with EC Directives

NSH-series PTs comply with EC Directives. Observe the following precautions to ensure that the customer's device and the overall machine also comply with EC Directives.

- 1,2,3...**
1. Use reinforced insulation or double insulation for the DC power supply to the PT. Ensure that a stable power output can be provided even if a 10-ms interruption occurs at the input.
  2. The PT conforms to the EN 61131-2, but the radiated emission characteristics (10-m regulations) may vary depending on the configuration of the control panel used, other devices connected to the control panel, wiring, and other conditions. You must therefore confirm that the overall machine or equipment complies with EC Directives.

# SECTION 1

## Introduction

This section describes the features, nomenclature, and functions of the NSH5 Programmable Terminal for first-time users.

1-1	Overview . . . . .	2
1-1-1	What Is the NSH5 Programmable Terminal? . . . . .	2
1-1-2	NSH5 Models . . . . .	2
1-1-3	NSH5 Features . . . . .	3
1-1-4	Product Specifications . . . . .	4
1-1-5	Applications . . . . .	4
1-1-6	Switch Output Configuration . . . . .	5
1-1-7	External Connections . . . . .	5
1-1-8	Safety Standards . . . . .	6
1-2	Nomenclature and Functions . . . . .	8
1-2-1	Front . . . . .	8
1-2-2	Back . . . . .	8
1-2-3	Top . . . . .	9
1-3	Special Cable Specifications . . . . .	10
1-3-1	Special Cable Models . . . . .	10
1-3-2	UL-standard Cable . . . . .	10
1-3-3	Loose-wire/D-Sub Cable . . . . .	16
1-3-4	Removable Box Cable . . . . .	20
1-3-5	External Wiring Diagram . . . . .	22
1-3-6	Interface Specifications . . . . .	22

## 1-1 Overview

### 1-1-1 What Is the NSH5 Programmable Terminal?

The NSH5 is an NSH-series Hand-held Programmable Terminal that provides both a touch panel and safety switches.

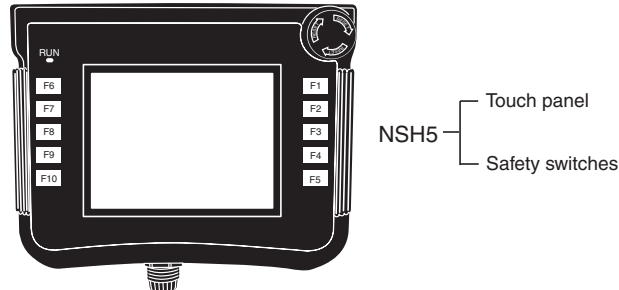

#### Touch Panel

The touch panel is the same as the one for NS5-series Programmable Terminals with touch panels. Connecting to an OMRON PLC by RS-232C or RS-422A does not require a program. Function switches are also provided.

#### Safety Switches

An emergency stop switch and an enabling switch are provided. Be sure to externally connect them to safety circuits.

Use safety circuits that are capable of detecting shorts in the emergency stop switch and enable switch.

### 1-1-2 NSH5 Models

There are two NSH5 models, one equipped with a red switch and the other with a gray switch. The switching function is the same for both.

- NSH5-SQR00B-V2 (equipped with a red switch for use as an emergency stop switch)  
This switch functions as the emergency stop switch so the PT must be mounted and used on a control panel in a way that it cannot be detached.
- NSH5-SQG00B-V2 (equipped with a gray switch for use as a stop switch)  
This functions as the stop switch and can be used in either the hand-held or mounted condition.

### 1-1-3 NSH5 Features

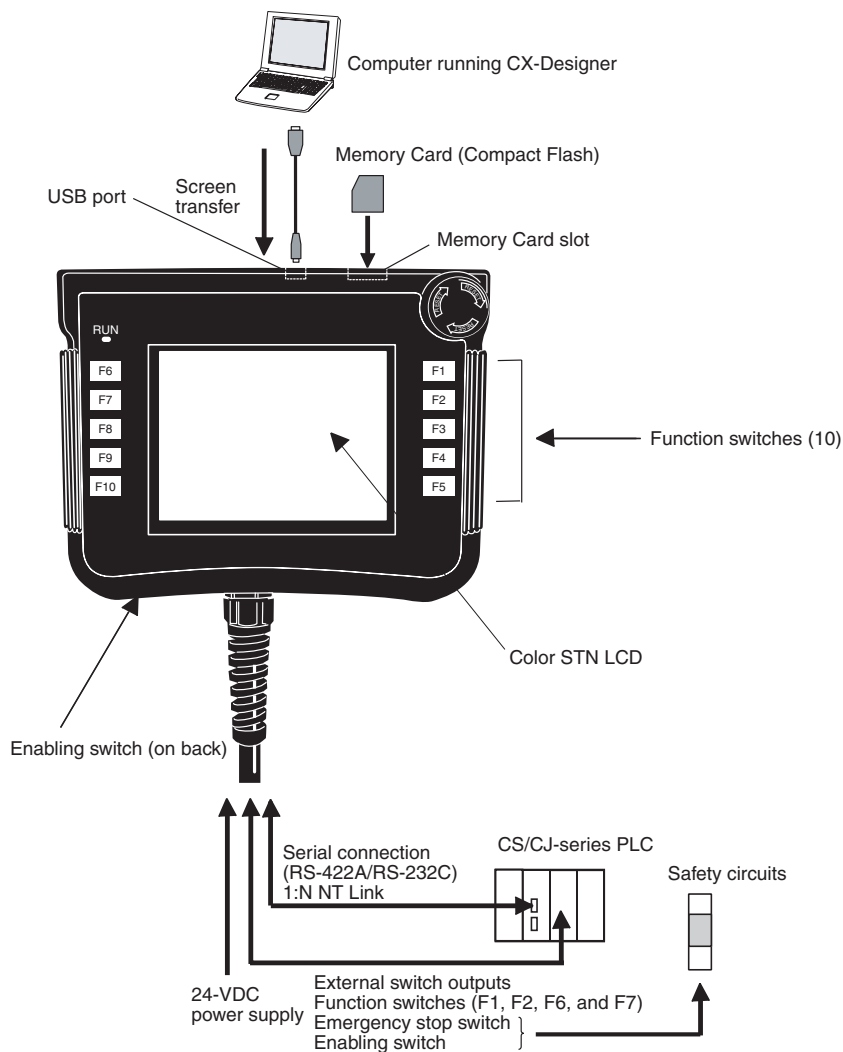

- Equipped with both an emergency stop switch and an enabling switch  
 There are two switches provided for stopping machine operation while using the touch panel. The emergency stop switch is for stopping operation intentionally, and the enabling switch is for stopping machine operation without taking conscious action.  
 The emergency stop switch (DPST-NC contact + NO bit) is allocated one bit in the internal memory or in the host (PLC) memory and is hard-wired to two external outputs. It has a direct opening mechanism.  
 The enabling switch (3-position DPST-NO) is hard-wired to an output. It has a direct opening mechanism, an easily confirmed click, and a rubber cover.
- Ten function switches (SPST-NO) are provided. They can be used for operations such as inching. Six of the function switches can be allocated bits in internal memory or host (PLC) memory, and four of the function switches can be output via hard-wired external outputs.
- Program-free connection is possible to an OMRON PLC via RS-232C or RS-422A.
- A 5.7-inch STN display with 256 colors (bit maps: 4,096 colors) is provided.



- The external end of the Special Cable (3 m, 10 m) has both a 9-pin D-Sub male connector, and loose wires for the emergency stop switch, enabling switch, and function switches.
- Screen transfers are enabled by connecting a computer running CX-Designer to the USB port (standard feature).
- Project data can be shared with panel-mounted NS-series Programmable Terminals.
- The Smart Active Parts library for NS-series PTs can be used.
- A Memory Card can be mounted to save screen data, data logs, operation logs, error logs, recipes, and image captures.
- The PT is waterproof to a IP65 degree of protection. (See note 1.)
- The PT withstands shock from dropping it from one meter (JIS B 3502 and IEC 61131-2). (See note 2.)
- The PT features a lightweight 1-kg hand-held design.
- The removable box is automatically detected when it's connected.

The box number is set using the DIP switch on the removable box. When the PT is connected, the box number is automatically detected and the screens corresponding to the box number are automatically displayed on the PT. At the same time, the PLC can be notified of the box number.

- Note**
- (1) Conformance is evaluated under applicable test conditions, and it may not be possible to use the PT in every environment. When used over a long period of time, the drip-proof packing may become damaged or dirty and lose its effectiveness.
  - (2) Conformance is evaluated under applicable test conditions, and it may not be possible to use the PT in every environment.

### 1-1-4 Product Specifications

Model	Specifications
NSH5-SQR00B-V2 NSH5-SQG00B-V2	5.7-inch color STN LCD <ul style="list-style-type: none"> <li>• Dots: 320 x 240</li> <li>• Colors: 256 (bit maps: 4,096)</li> <li>• Screen capacity: 20 MB</li> <li>• 1 USB port (for transferring screen from the CX-Designer) Commercially available USB cable can be connected.</li> <li>• Memory Card: Can be mounted.</li> <li>• Serial communications: Either RS-232C or RS-422A, depending on the Special Cable used. The serial communications mode is 1:N NT Link.</li> <li>• 1 emergency stop switch (DPST-NC contact + NO bit)</li> <li>• 1 enabling output (DPST-NO)</li> <li>• 10 function outputs</li> </ul>

### 1-1-5 Applications

- Setting parameters and monitoring operation when starting up equipment or switching processes
- Setting parameters and monitoring operation when an error occurs
- Setting parameters and monitoring operation anywhere in expansive facilities

### 1-1-6 Switch Output Configuration

The emergency stop switch uses DPST-NC contact + NO bit. Of these, DPST-NC contacts are used for external hardware outputs. The remaining NO bit can be allocated any bit in the internal memory or in the host (PLC) memory.

Six function switches can be allocated any bits in the internal memory or in the host (PLC) memory. Four of the function switches can be output to external contact outputs.

The enabling switch (DPST-NO) can also be output to external contact outputs.

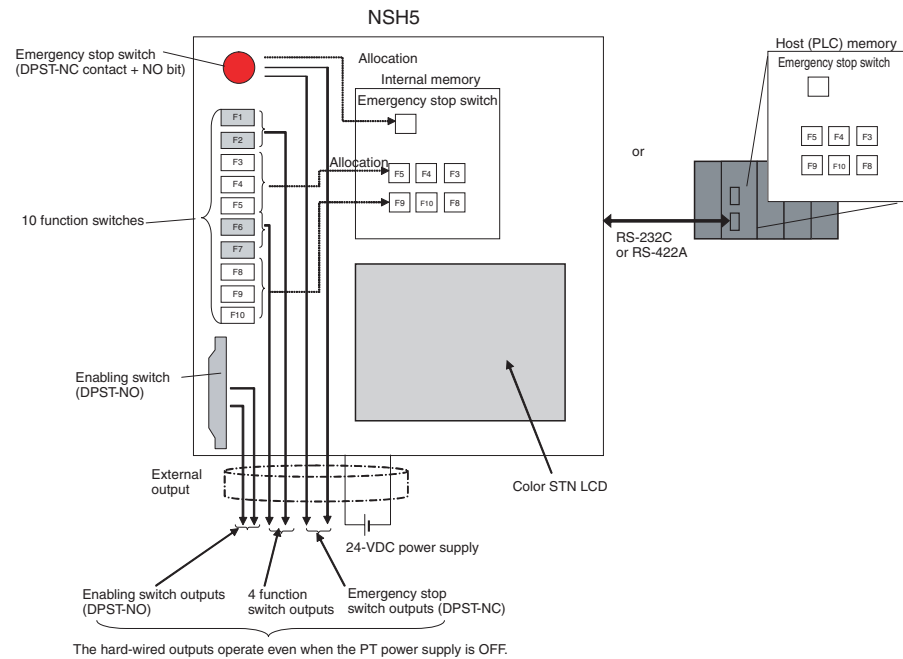

### 1-1-7 External Connections

Use a Special Cable (NSH5-232/422-CW-□□M, UL type: NSH5-232/422UL-□□M), loose-wires and D-Sub connector on one end) to connect the signals as follows:

- Emergency stop switch/stop switch  
When using as a safety system, connect to safety components. (Do not connect to the PLC.)
- Enabling switch  
When using as a safety system, connect to safety components. (Do not connect to the PLC.)
- Serial communications (RS-232C or RS-422A)  
Connect to the serial port of the PLC.
- Function switches  
Connect to an DC Input Unit of the PLC.

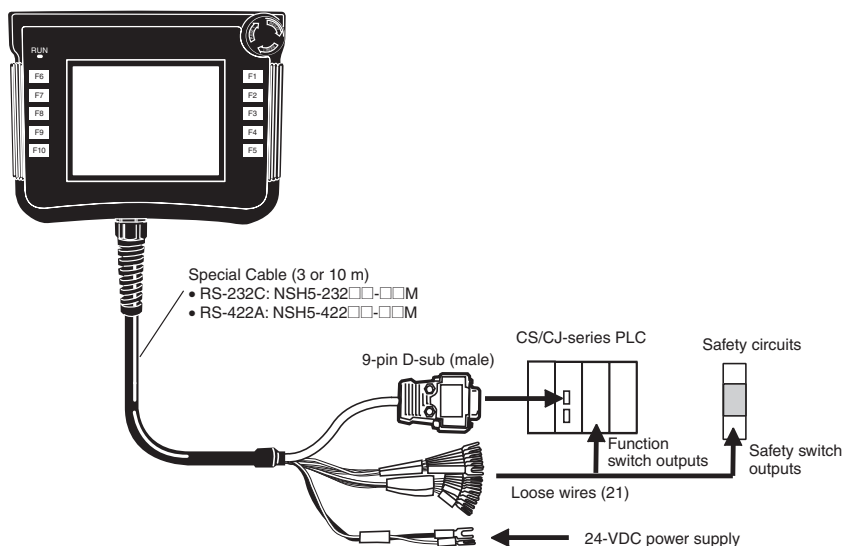

- Note**
- (1) When used in a safety control system, the emergency stop switch and enabling switch must be connected to a safety circuit.
  - (2) Do not use the function switches or the touch switches on the touch panel as emergency stop switches in situations involving potential risk to human life or serious damage.
  - (3) Use safety circuits that are capable of detecting shorts in the emergency stop switch and enable switch.

## 1-1-8 Safety Standards

### Overview of Standards

#### General Standards

EN 954-1  
 Safety-related Parts of Control Systems  
 Part 1: General Principles for Design  
 ISO Standards: ISO 13849-1; JIS Standards: JIS B 9705-1

#### Summary

This standard applies to design procedures for parts in control systems that involve safety.

#### Main Point

The levels for machines are determined by taking into consideration the degree of anticipated damage (from light to heavy) and the rate of occurrence (from rare to frequent). The danger level is classified into five categories, and for each category the safety functions that should be provided for control parts are specified.

EN 60204-1  
 Electrical Equipment of Machines  
 Part 1: Specification for General Requirements  
 IEC Standards: IEC 60204-1; JIS Standards: JIS B 9960-1

#### Summary

This standard applies to electrical devices in which the power supply nominal voltage between lines is less than 1,000 V (for AC) or 1,500 V (for DC), and the nominal frequency is less than 200 Hz.

**Main Point**

The standard covers all of the elements required in electrical devices, such as control circuits, functions, and devices for electrical and electronic equipment, safety measures, and technical materials related for installation, operation, and maintenance.

**Standard Related to Safety Switches**

EN 60947-5-1 Low-voltage Switching Gear and Control Gear Part 5: Control Circuit Devices and Switching Elements Section 1: Electromechanical Control Circuit Devices IEC Standards: IEC 60947-5-1; JIS Standards: JIS C 8201-5-1
--

**Summary**

This standard applies to switching elements and control circuit devices created for purposes such as control of switching control equipment, signals, and interlock.

**Main Points**

Section 1: General Requirements

Section 2: Special Requirements for Indicator Lights

Section 3: Special Requirements for Direct Opening Operations

The standards cover topics such as switching capacity, temperature rise, terminal strength, protective construction, and direct opening operations.

**Standard Regarding Emergency Stop Equipment**

EN 418 Emergency Stop Equipment Functional Aspects: Principles for Design ISO Standards: ISO 13850; JIS Standards: JIS B 9703
--

**Summary**

This standard prescribes the design principles for emergency stop equipment.

**Main Points**

A direct opening mechanism must be provided.

A self-holding mechanism must be provided.

The stopping device must be in a form that is easy to operate, such as a protruding pushbutton, a wire, or a rope.

The stopping device must be red with a yellow background.

The following safety standards apply to the NSH5 PT.

- Based on EN 60204-1
- Complies with EN 954-1

**EN 60204-1 Safety Standard**

IEC204-1 (EN60204-1: Electrical Safety Standard for Machinery) stipulates that an emergency stop switch must be red, and a stop switch must be gray or black. When detaching and using the PT separate from the system, always use a PT with a gray switch.

In the EN60204-1 safety standard, emergency stop and emergency shutdown are defined as emergency switches.

Emergency stop	Stop category 0 or 1
Emergency shutdown	Stop category 0 only

**Standards Applicable to the NSH5**

It is stipulated in EN 60204-1 that the pushbutton for an emergency stop must be red and the background yellow. In SEMI-S2 as well, the background for an emergency shutdown pushbutton must be yellow.

To comply with these standards, a yellow seal is included with the product to affix around the emergency stop switch.

**EN 954-1 General Design Principles**

Redundant conformity is provided with an enabling switch and an emergency stop switch. The emergency stop switch is a three-pole switch (3PST-NC), with a DPST-NC contact structure and a SPST-NC contact structure for an emergency stop notification signal.

**1-2 Nomenclature and Functions**

**1-2-1 Front**

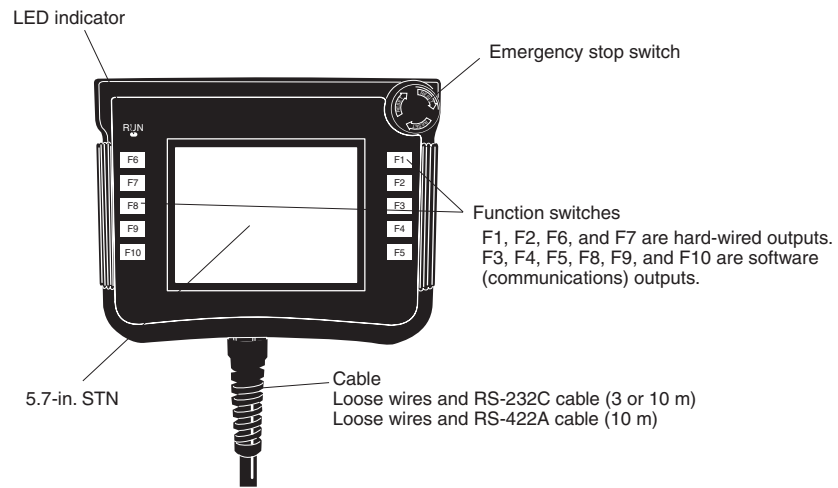

**1-2-2 Back**

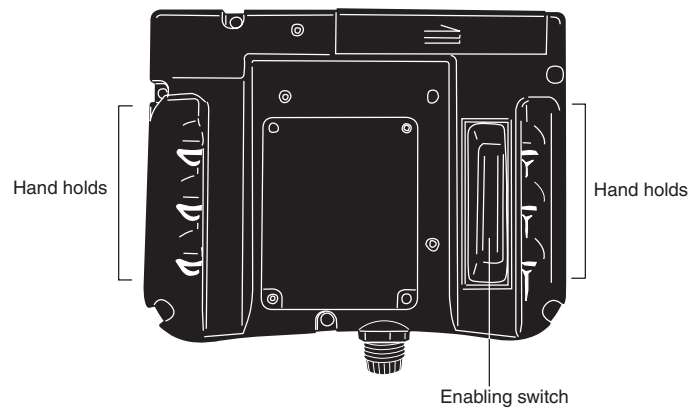

1-2-3 Top

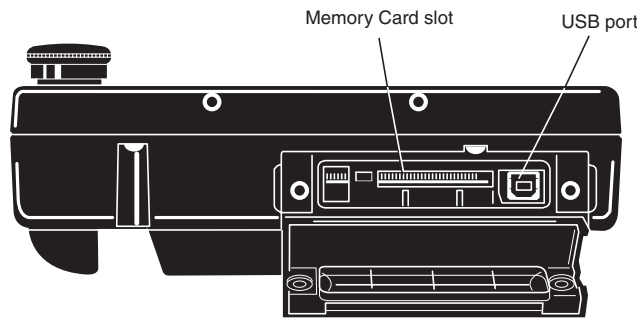

Display Section

Effective display area: 5.7 inches  
 Liquid crystal: Color STN LCD with backlight  
 Number of dots: 320 × 240  
 Number of display colors: 256 (BMP/JPG images: 4,096)

RUN Indicator

The NSH5 status indicator is described in the following table.

Color	Green	Orange	Red
RUN Indicator			
Lit	Normal operation	<ul style="list-style-type: none"> <li>• Checking file system at startup.</li> <li>• Normal operation with battery voltage low or battery disconnected.</li> </ul>	Error occurred at startup.
Flashing	<ul style="list-style-type: none"> <li>• Memory Card transfer completed normally.</li> <li>• Backlight error discovered after startup.</li> </ul>	Memory Card transfer in progress.	Error occurred during Memory Card transfer.
Not lit	<ul style="list-style-type: none"> <li>• Power is not being supplied.</li> <li>• A fuse is burned out.</li> <li>• A system program is damaged and cannot boot.</li> </ul>		

Switch Section

**OMRON A165E-S-03U Emergency Stop Switch**

DPST-NC contact: External output  
 Rated voltage: 24 V  
 Maximum rated current: 100 mA (minimum applicable load: 1 mA at 5 VDC)  
 NO bit: Allocated in internal memory or host (PLC)

**OMRON A4E-B200VA Enabling Switch**

DPST-NO contact: External output  
 Rated voltage: 24 V  
 Maximum rated current: 100 mA (minimum applicable load: 4 mA at 24 VDC)  
 3-position switch  
 Operating patterns:  
     Operation: OFF to ON to OFF  
     Reset: OFF to ON, momentary 3-position operation

**Function Switches**

F1, F2, F6, and F7: External outputs

Rated voltage: 24 V

Maximum rated current: 50 mA

F3, F4, F5, F8, F9, and F10: Allocated bits in internal memory or host (PLC)

**Memory Card Section**

A HMC-EF372 (30 MB) or HMC-EF672 (64 MB) Memory Card can be mounted. Screen data, data logs, operation logs, error logs, recipes, and image captures can be saved.

**USB Port**

The USB port is connected to a computer using a commercially available USB cable, and used to transfer screens.

**Serial Communications Port**

The serial port is used for RS-232C or RS-422A communications through the Special Cable.

Serial communication mode: NT link (1:N mode)

**Special Cable Connectors (Inside Back Cover)**

CN1: 24-VDC power supply inputs

CN2: Serial interface.

CN3: External outputs.

## 1-3 Special Cable Specifications

### 1-3-1 Special Cable Models

Loose-wire/D-Sub, UL-standard, and Removable Box Cables are available. Cables are provided for both RS-232C and RS-422A depending on the serial communications protocol.

Cable type	Communications connector	Serial communications	Model	Length
Loose-wire/ D-Sub	9-pin D-Sub + Loose wires	RS-232C	NSH5-232CW-3M	3 m
			NSH5-232CW-10M	10 m
UL-standard	9-pin D-Sub + Loose wires	RS-422A	NSH5-422CW-10M	10 m
			Loose wires + relay cable	RS-232C
	Loose wires	RS-422A		
Removable Box	37-pin D-Sub	RS-232C	NSH5-232CN-3M	3 m
			NSH5-232CN-10M	10 m

**Note** Always use a UL-standard Cables for applications requiring UL certification.

### 1-3-2 UL-standard Cable

**Wiring Hard-wired Signals**

The function keys and the emergency stop switch are directly connected via the connecting cable to the PLC or device I/O terminals.

**Wiring the Serial Communication Line**

Depending on the type of cable, there are two types of serial communications wiring: RS-232C connector and RS-422A connector. The RS-232C type comes equipped with a relay cable. This type can connected to the RS-232C port of the OMRON CS/CJ series PLC. The RS-422A type has a loose-wire connector, and the signal must be converted by the CJ1W-CIF11 Conversion Unit, then connected to the RS-232C port of the OMRON CS/CJ series PLC.

**Mounting to a Control Panel**

Use the dimensions shown below as a guide to cut a hole in the control panel. Feed the UL-standard cable through the hole, then secure the cable to the control panel from both inside and out, using the cable mounting fitting and a Skintop. When using the NSH5-232UL-3M/10M, always connect the relay cable, which is equipped with an RS-232C type connector, after feeding the UL-standard cable through the wall of the control panel.

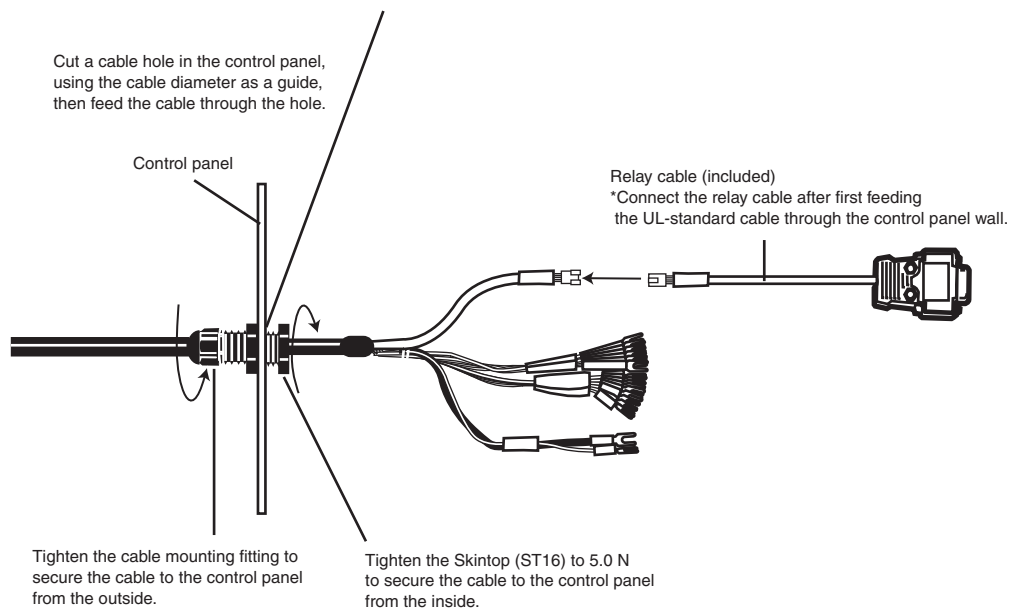
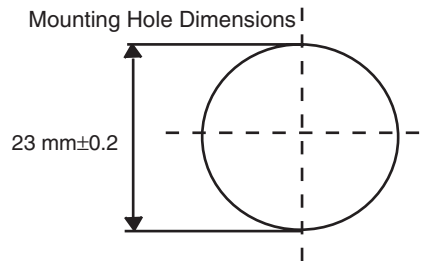



Cable Dimensions

NSH5-232UL-3M/10M

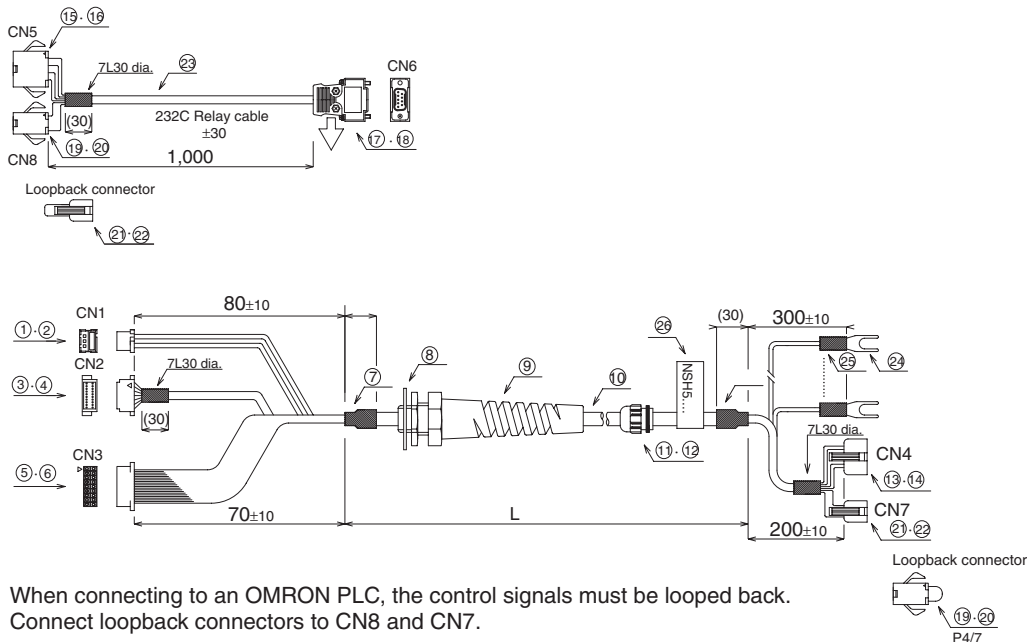

No.	Circuit symbol	Product name	Model	Maker	Quantity	Unit
1	CN1	Housing	DF3-3S-2C	HRS	1	Piece
2	CN1	Crimp terminal	DF3-2428SCFC	HRS	3	Piece
3	CN2	Housing	SHDR-20V-S-B	JST	1	Piece
4	CN2	Crimp terminal	SSH-003GA-P0.2	JST	8	Piece
5	CN3	Housing	DF11-18DS-2C	HRS	1	Piece
6	CN3	Crimp terminal	DF11-2428SCFA	HRS	18	Piece
7		Heat-shrinkable tube	SUMITUBE FS (Z), 14-mm dia., black	Sumitomo	0.06	m
8		Gasket	GMP-20	LAPP	1	Piece
9		Skintop	BS-M20 × 1.5	LAPP	1	Piece
10		Cable	2464 composite, 27-conductor, shield	BANDO ELECTRIC WIRE	L	m
11		Skintop	ST-PG16	LAPP	1	Piece
12		Lock nut	GMK-16	LAPP	1	Piece
13	CN4	Housing	SMR-04V-N	JST	1	Piece
14	CN4	Crimp terminal	SYM-001T-p0.6	JST	4	Piece
15	CN5	Housing	SMP-04V-NC	JST	1	Piece
16	CN5	Crimp terminal	SHF-001T-0.8BS	JST	4	Piece
17	CN6	D-Sub 9-pin plug	XM2A-0901	OMRON	1	Piece
18	CN6	D-Sub 9-pin hood	XM2S-0911	OMRON	1	Piece
19	CN7	Housing	SMR-02V-N	JST	2	Piece
20	CN7	Crimp terminal	SYM-001T-p0.6	JST	4	Piece
21	CN8	Housing	SMP-02V-NC	JST	2	Piece
22	CN8	Crimp terminal	SYM-001T-p0.6	JST	4	Piece

No.	Circuit symbol	Product name	Model	Maker	Quantity	Unit
23		Cable	BIOS-A-2805P	BANDO ELECTRIC WIRE	1	m
24		Crimp terminal	0.5-3.7A	JST	21	Piece
25		Heat-shrinkable cable	SUMITUBE F (Z), 2-mm dia., white	Sumitomo		m
26		Label	NSH5-232UL-10M·LOT No.		1	Piece

NSH5-422UL-10M

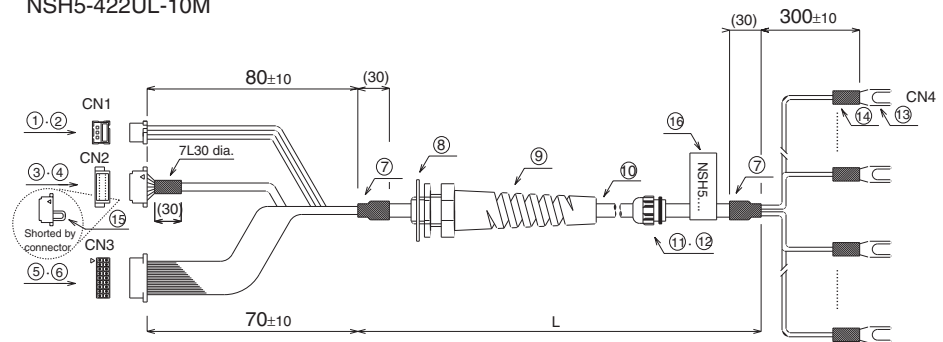

No.	Circuit symbol	Product name	Model	Maker	Quantity	Unit
1	CN1	Housing	DF3-3S-2C	HRS	1	Piece
2	CN1	Crimp terminal	DF3-2428SCFC	HRS	3	Piece
3	CN2	Housing	SHDR-20V-S-B	JST	1	Piece
4	CN2	Crimp terminal	SSH-003GA-P0.2	JST	8	Piece
5	CN3	Housing	DF11-18DS-2C	HRS	1	Piece
6	CN3	Crimp terminal	DF11-2428SCFA	HRS	18	Piece
7		Heat-shrinkable tube	SUMITUBE F2 (Z), 14-mm dia., black	Sumitomo	0.06	m
8		Gasket	GMP-20	LAPP	1	Piece
9		Skintop	BS-M20 × 1.5	LAPP	1	Piece
10		Cable	2464 composite, 27-conductor, shield	BANDO ELECTRIC WIRE	L	m
11		Skintop	ST-PG16	LAPP	1	Piece
12		Lock nut	GMK-16	LAPP	1	Piece
13		Crimp terminal	0.5-3.7A	JST	29	Piece
14		Heat-shrinkable cable	SUMITUBE F (Z), 2-mm dia., white	Sumitomo		m
15		Cable	UL1061# 28 black			Piece
16		Label	NSH5-232UL-10M·LOT No.		1	Piece

RS-232C Wiring

CN1

Pin No.	Signal	Pin No.	Signal	Wire size
1	FG	Forked terminal	FG	Outer shield
2	0V	Forked terminal	0V	AWG24
3	24V	Forked terminal	24V	AWG24

CN3

Pin No.	Signal	Pin No.	Signal	Wire size
1	F1	Forked terminal	F1	AWG28
2	F2	Forked terminal	F2	AWG28
3	F6	Forked terminal	F6	AWG28
4	F7	Forked terminal	F7	AWG28
5	SWCOM	Forked terminal	SWCOM	AWG28
6	EMG1A1	Forked terminal	EMG1A1	AWG28
7	EMG1A2	Forked terminal	EMG1A2	AWG28
8	EMG2A1	Forked terminal	EMG2A1	AWG28
9	EMG2A2	Forked terminal	EMG2A2	AWG28
10	ENB1A1	Forked terminal	ENB1A1	AWG28
11	ENB1A2	Forked terminal	ENB1A2	AWG28
12	ENB2A1	Forked terminal	ENB2A1	AWG28
13	ENB2A2	Forked terminal	ENB2A2	AWG28
14	0V(SG)	Forked terminal	0V(SG)	AWG28
15	S4	Forked terminal	S4	AWG28
16	S3	Forked terminal	S3	AWG28
17	S2	Forked terminal	S2	AWG28
18	S1	Forked terminal	S1	AWG28

CN2

Pin No.	Signal
1	SD
2	RD
3	RS
4	CS
5	NC
6	0V(SG)
7	NC
8	NC
9	SDB+
10	SDA-
11	RDB+
12	RDA-
13	RSB+
14	RSA-
15	FG
16	NC
17	NC
18	NC
19	NC
20	NC

CN4

Pin No.
1
2
3
4

CN7

Pin No.
1
2

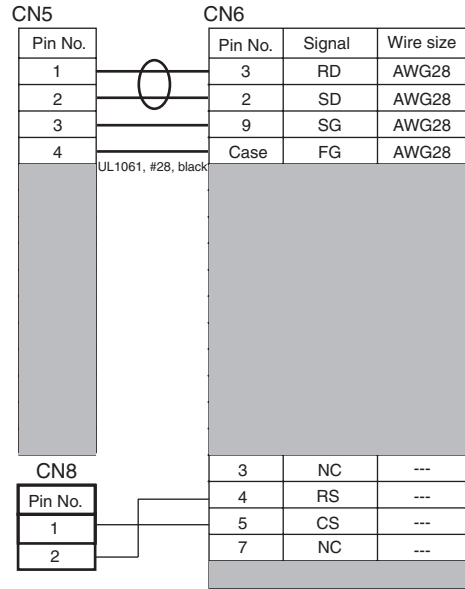

RS-422A Wiring

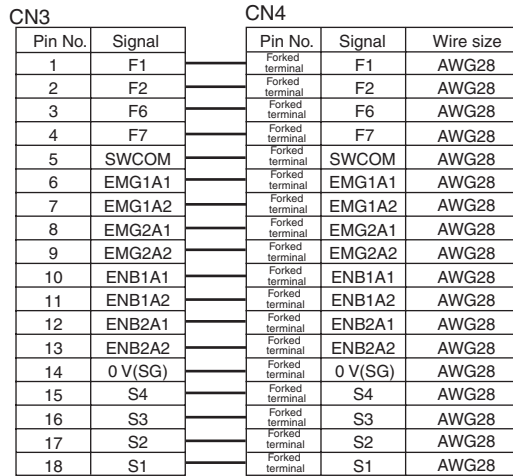
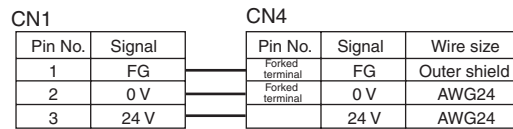

CN2		CN4		
Pin No.	Signal	Pin No.	Signal	Wire size
1	SD			
2	RD			
3	RS			
4	CS			
5	NC			
6	0 V(SG)	Forked terminal	0 V(SG)	AWG28
7	Loop_Close	7	---	---
8	Loop_Close	8	---	---
9	SDB+	Forked terminal	SDB+	AWG28
10	SDA-	Forked terminal	SDA-	AWG28
11	RDB+	Forked terminal	RDB+	AWG28
12	RDA-	Forked terminal	RDA-	AWG28
13	RSB+	Forked terminal	RSB+	AWG28
14	RSA-	Forked terminal	RSA-	AWG28
15	FG	Forked terminal	FG	Inner shield
16	NC	3	---	---
17	NC	4	---	---
18	NC	5	---	---
19	NC	7	---	---
20	NC			

### 1-3-3 Loose-wire/D-Sub Cable

#### Wiring Hard-wired Signals

The function keys and the emergency stop switch are directly connected via the connecting cable to the PLC or device I/O terminals.

#### Wiring the Serial Communications Line

Depending on the type of cable, there are two types of serial communications wiring: RS-232C connector and RS-422A connector. For RS-232C or RS-422A connector, the connector is a 9-pin male D-Sub connector and can be directly connected to the RS-232C or RS-422A port of an OMRON CS/CJ-series PLC.

A conversion cable must be prepared in order to connect to any other host.

#### Cable Dimensions

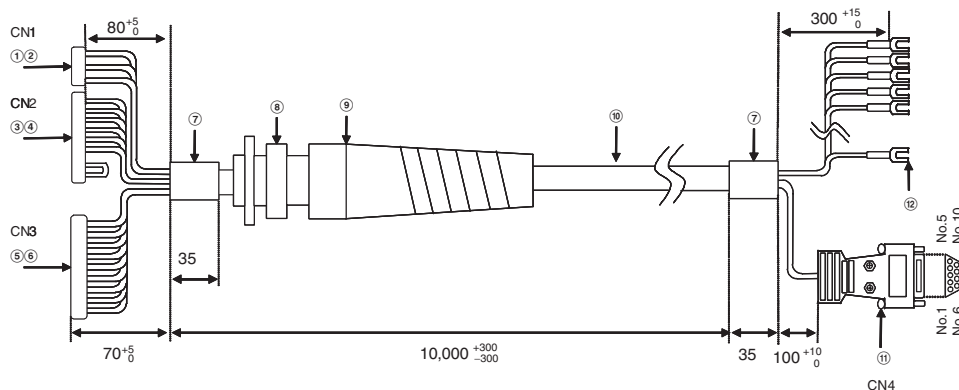

No.	Product name	Model	Maker	Quantity
①	Pressure-welded socket	DF3-3S-2R26(01)	HRS	1
②	Socket crimp terminal	DF3-2428SCC	HRS	3

No.	Product name	Model	Maker	Quantity
③	Housing	SHDR-10V-S-B-LF-SN	J.S.T. Mfg. Co.	1
④	Contact	SSH-003GA-P0.2-LF-SN	J.S.T. Mfg. Co.	8
⑤	Crimp socket	DF11-18DS-2C	HRS	1
⑥	Socket crimp terminal	DF11-2428SCA	HRS	18
⑦	Heat-shrinkable tube	Sumi-tube	Sumitomo	1
⑧	Gasket	GPM20	LAPP KABLE	1
⑨	Skintop (black)	BS-M20 × 1.5	LAPP KABLE	1
⑩	Cable	UL20233-SLB (black) 2Cx#24+4Px#28+26Cx#28	LAPP KABLE	1
⑪	Forked terminal	---	---	21
⑫	9-pin D-Sub plug	XM2A-09	OMRON	1
⑬	9-pin D-Sub hood	XM2S-09	OMRON	1

RS-232C Wiring

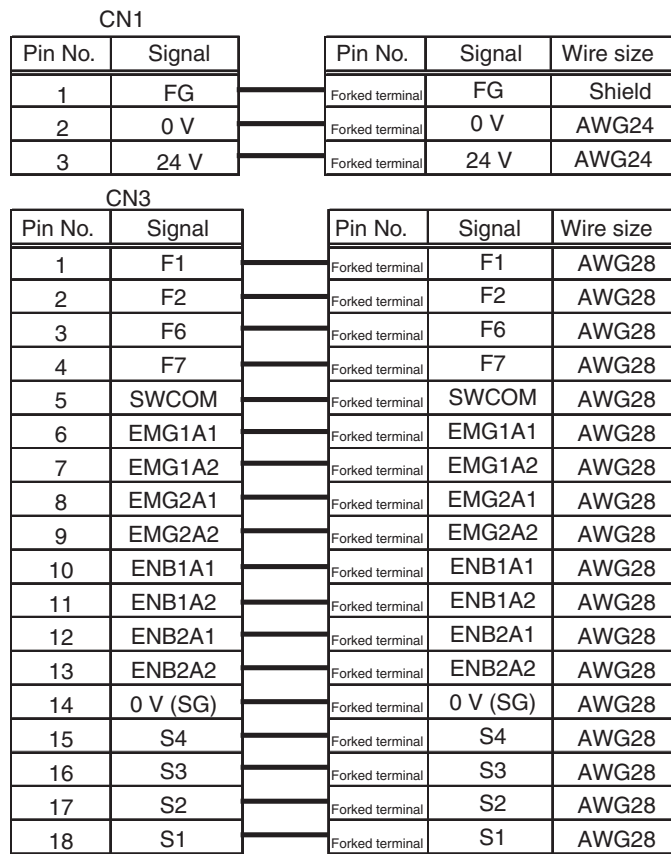

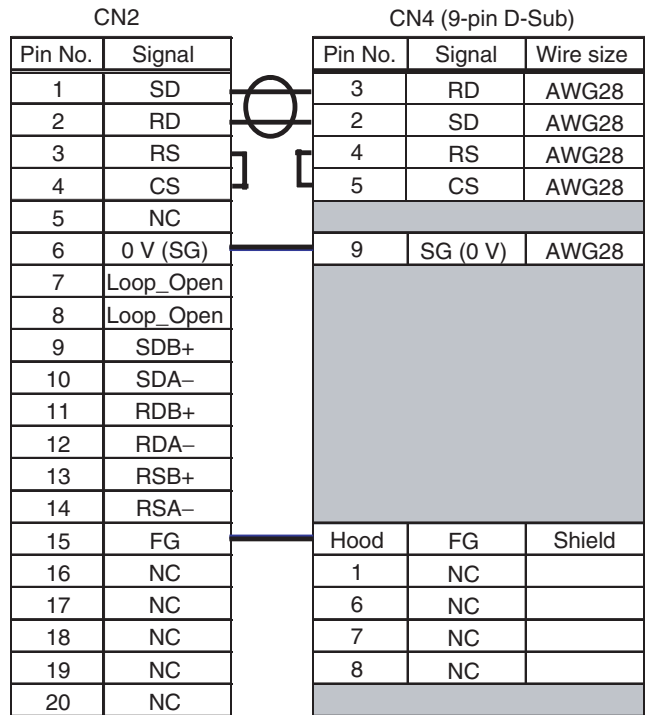

RS-422A Wiring

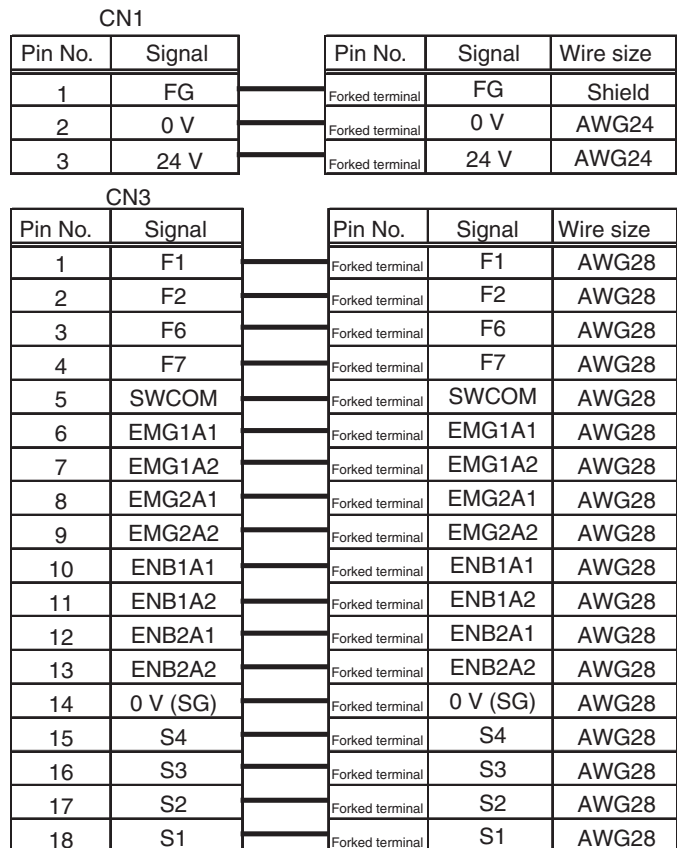

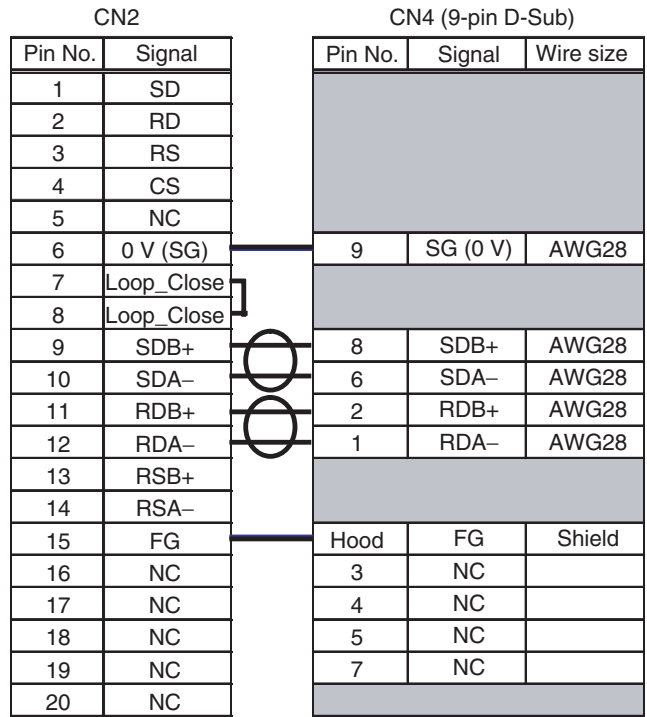



### 1-3-4 Removable Box Cable

#### Wiring Hard-wired Signals

The function keys and the emergency stop switch are connected through the Removable Box connected via the Removable Box Cable and output to safety circuits or other circuits connected to the hard-wired terminal block.

#### Wiring the Serial Communications Line

There is only one type of RS-232C connector. It is a 37-pin male D-Sub connector and can be directly connected to the RS-232C port on the NSH5-AL001 Removable Box.

#### Cable Dimensions

##### NSH5-232CN-3M/10M

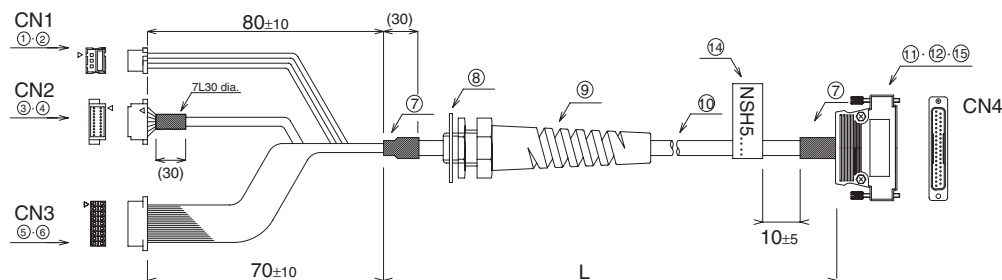

No.	Circuit symbol	Product name	Model	Maker	Quantity	Unit
1	CN1	Housing	DF3-3S-2C	HRS	1	Pieces
2	CN1	Crimp Terminal	DF3-2428SCFC	HRS	3	Pieces
3	CN2	Housing	SHDR-20V-S-B	JST	1	Pieces
4	CN2	Crimp Terminal	SSH-003GA-P0.2	JST	8	Pieces
5	CN3	Housing	DF11-18DS-2C	HRS	1	Pieces
6	CN3	Crimp Terminal	DF11-2428SCFA	HRS	18	Pieces
7		Heat-shrinkable Tube	SUMITUBE F2 (Z), 14-mm dia., black	Sumitomo	0.06	m
8		Gasket	GMP-20	LAPP	1	Pieces
9		Skintop	BS-M20 × 1.5	LAPP	1	Pieces
10		Cable	2464 composite, 27-conductor, shield	Bando Electric Wire	L	m
11	CN4	D-SUB37P Plug	XM2A3701	OMRON	1	Pieces
12	CN4	D-SUB37P Hood	XM2A3711	OMRON	1	Pieces
13		Cable	UL1061AWG28 yellow	Kyowa Electronic Instruments	0.06	m
14		Label	NSH5-232CN-3M-LOT No.		1	Pieces
15		Jack Screw	XM2Z-0071	OMRON	2	Pieces

RS-232C Wiring

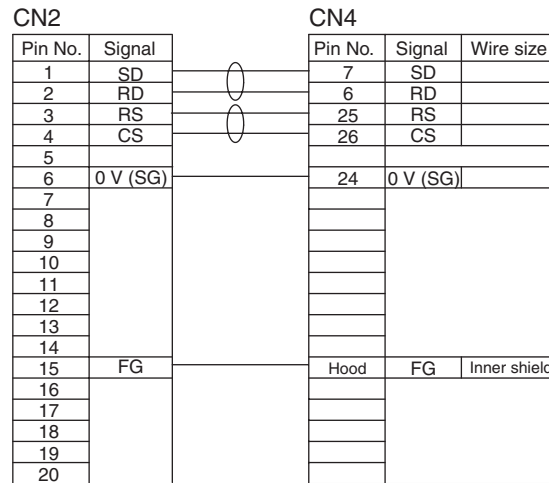
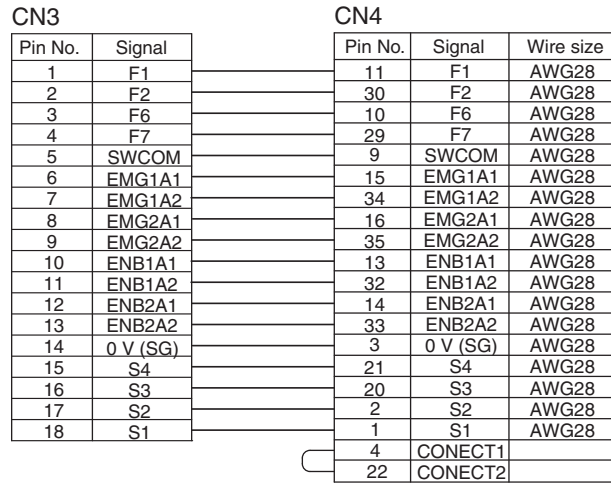
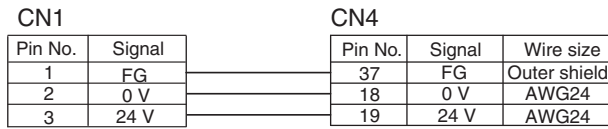

### 1-3-5 External Wiring Diagram

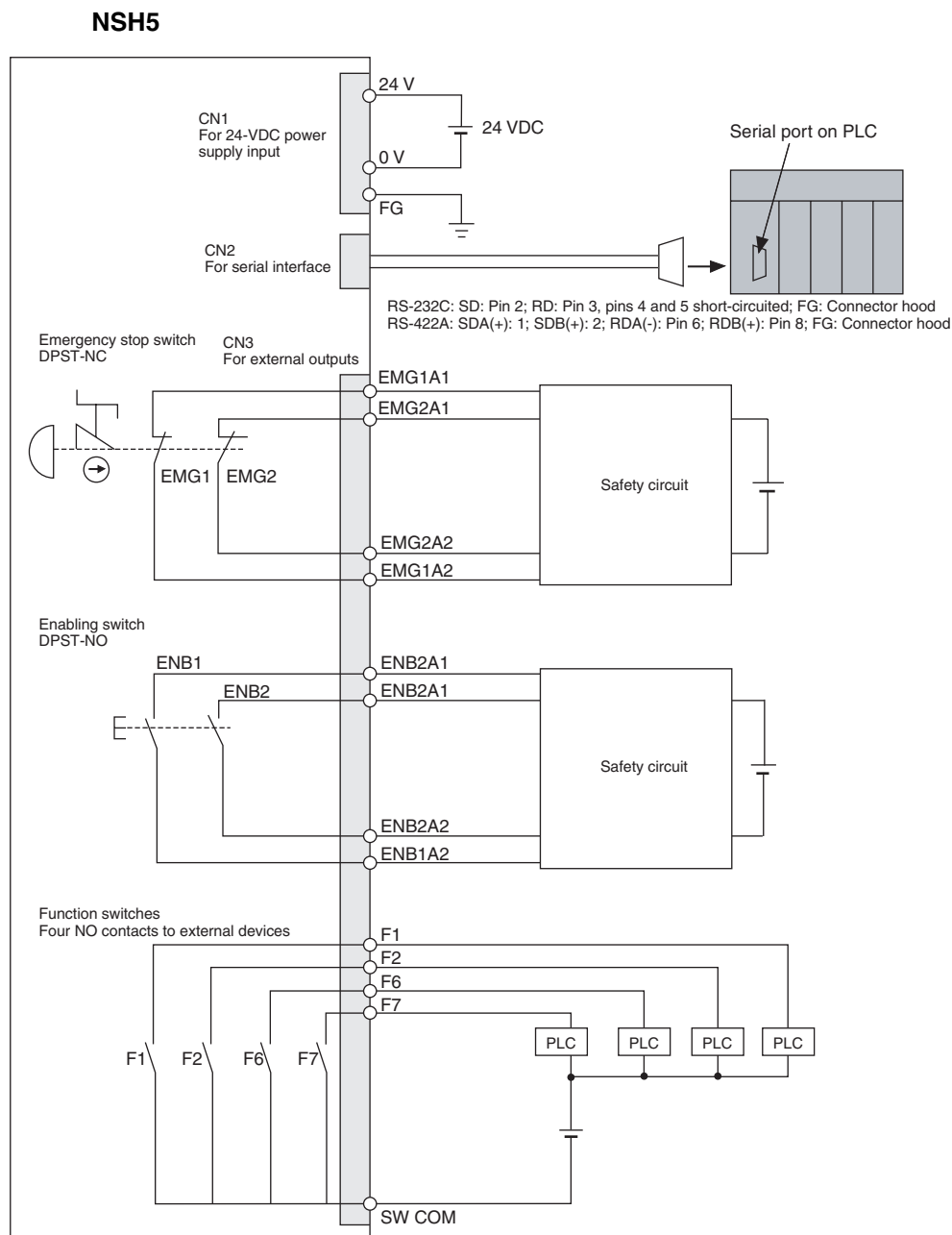

### 1-3-6 Interface Specifications

#### 24-VDC Interface (CN1)

Pin No.	Signal	Contents
1	FG	Frame ground
2	0 V	0-V power supply input
3	24 VDC	+24-V power supply input

Serial Interface RS-232C/  
422A (CN2)

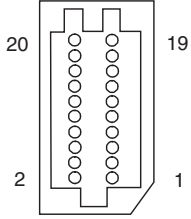
	Pin No.	Signal	Contents
		1	SD
2		RD	Receive Data
3		RS	Request Send
4		CS	Clear to Send
5		NC	Not connected
6		0 V (SG)	0 V
7		Loop Close	Loop Close
8		Loop Close	Loop Close
9		SDB+	Send Data B
10		SDA-	Send Data A
11		RDB+	Receive Data B
12		RDA-	Receive Data A
13		RSB+	Not connected
14		RSA-	Not connected
15		FG	Hood
16		NC	Not connected
17		NC	Not connected
18		NC	Not connected
19		NC	Not connected
20		NC	Not connected

External Output Interface  
(CN3)

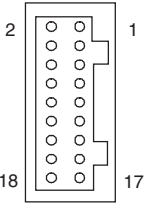
	Pin No.	Signal	Contents
		1	F1
2		F2	Function switch F2
3		F6	Function switch F6
4		F7	Function switch F7
5		SWCOM	Function switch common
6		EMG1 A1	Emergency stop switch line 1
7		EMG1 A2	Emergency stop switch line 1
8		EMG2 A1	Emergency stop switch line 2
9		EMG2 A2	Emergency stop switch line 2
10		ENB1 A1	Enabling switch line 1
11		ENB1 A2	Enabling switch line 1
12		ENB2 A1	Enabling switch line 2
13		ENB2 A2	Enabling switch line 2
14		0 V (SG)	Station ID line 0 V
15		S4	Station ID line 4
16		S3	Station ID line 3
17		S2	Station ID line 2
18		S1	Station ID line 1

**Note** For details on station numbers, refer to 3-9 Station Detection Function.



# SECTION 2

## Grounding and Connections

This section describes wiring and grounding the power supply and how to connect the NSH5 Programmable Terminal using the Special Cable.

- 2-1 Installation Environment . . . . . 26
- 2-2 Power Supply and FG Wiring . . . . . 26
  - 2-2-1 Power Supply Wiring . . . . . 26
  - 2-2-2 FG Wiring . . . . . 27
- 2-3 Connecting the Special Cable . . . . . 28
- 2-4 Attaching the Hand Strap . . . . . 32
- 2-5 Installing the Mounting Bracket . . . . . 33

## 2-1 Installation Environment

Observe the following precautions when installing an NSH5 Programmable Terminal.

### Precautions

Do not install the PT in the following locations.

- Locations subject to severe changes in temperature
- Locations subject to temperatures or humidity outside the range specified in the specifications
- Locations subject to condensation as a result of severe changes in temperature
- Locations subject water, oil, or chemical spray
- Locations subject to corrosive or flammable gases
- Locations subject to shock or vibration
- Locations outdoors directly subject to wind or rain
- Locations subject to strong ultraviolet light

Take appropriate and sufficient countermeasures when installing systems in the following locations.

- Locations subject to static electricity or other forms of noise
- Locations subject to strong electromagnetic fields
- Locations close to power lines
- Locations subject to possible exposure to radioactivity

**Note** Before unpacking the PT or Peripheral Devices, look the product over and check for any damage. Gently shake the product and listen for any abnormal sounds.

## 2-2 Power Supply and FG Wiring

### 2-2-1 Power Supply Wiring

Connect a 24-VDC power supply to the power supply input terminals. The following table shows the specifications for the power supply that can be connected. Determine the power supply specifications so that the power supply capacity is satisfied.

Item	Specifications
Power supply voltage	24 VDC
Allowable power supply voltage fluctuation range	20.4 to 27.6 VDC (24 VDC $\pm$ 15%)
Power supply capacity	10 W min.

Wire the power supply input terminals to the 24-VDC power supply as shown below.

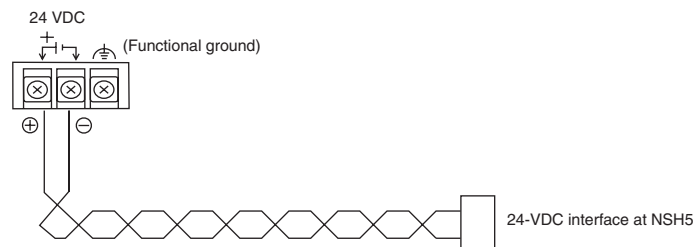

**Note** (1) Do not connect an AC power supply to the power supply terminals.

- (2) Use a DC power supply with little voltage fluctuation.
- (3) Do not perform a dielectric strength test.
- (4) To comply with the Low-voltage Directive in the EC Directives, use a power supply with reinforced insulation. Reinforced insulation is a single insulation method that can protect against electrical shock to the same degree as double insulation.  
Recommended model: S82K-03024 (manufactured by OMRON)
- (5) Insert a 3-A fuse immediately after the secondary output from the power supply.
- (6) To comply with UL-recognized standards, always use a Class 2 power supply. A Class 2 power supply refers to one in which the current and voltage levels of the product's secondary output are both limited (100 VA max.), and which has undergone and passed the necessary tests for UL certification.

## 2-2-2 FG Wiring

The cable connected to the PT has a functional ground terminal (FG)  
Wire them according to the conditions described below.

- 1,2,3...**
1. If there is a ground potential difference between the NSH5 and the host, install them as shown in the following diagram.  
Do not ground the PT if there is a distance between the PT and the ground and one-point grounding is difficult.
  2. If the PT is installed in the same panel as a source of noise, such as a motor or an inverter, do not ground the PT.

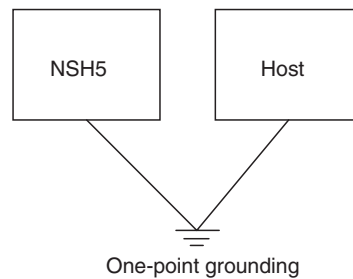

Be sure to ground correctly to prevent malfunctioning due to noise.



## 2-3 Connecting the Special Cable

This section describes how to connect the Special Cable to the PT.

### Connection Procedure

- 1,2,3...** 1. Using a screwdriver, loosen the four screws on the PT back cover.

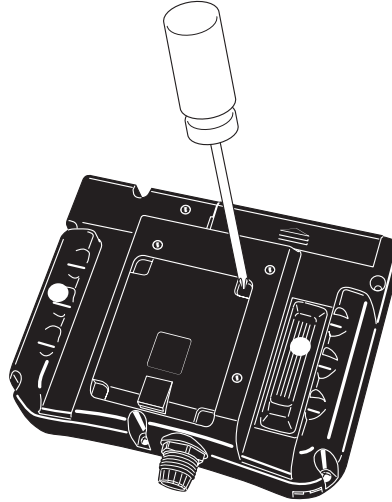

2. After the screws have been removed, grasp the cover by the hand holds and lift it out.

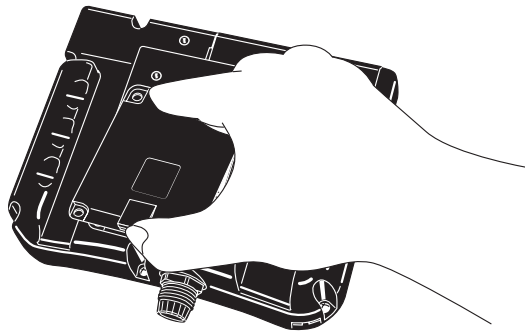

When the cover has been removed and the back of the PT is open as shown below, the I/O interface on the board in the PT can be seen. For details on DIP switch settings and interface specifications, refer to *Appendix A General Specifications*.

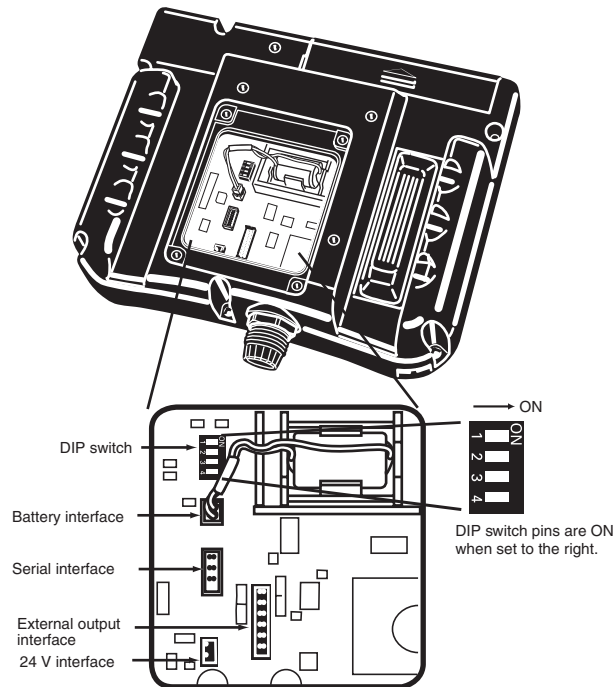

- 3. Insert the Special Cable from the cable inlet.

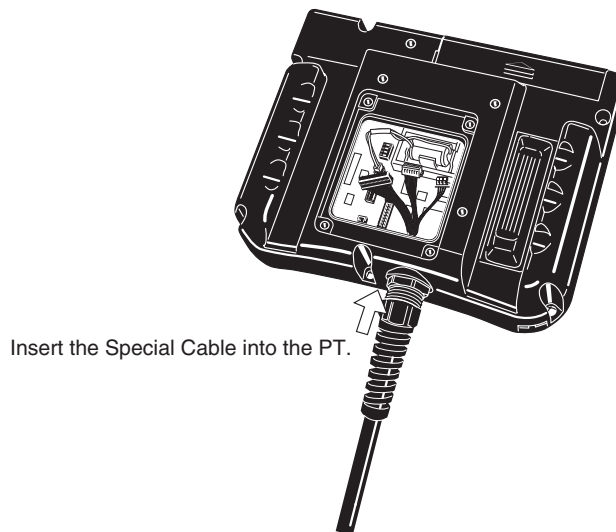

4. Connect each connector as shown below.

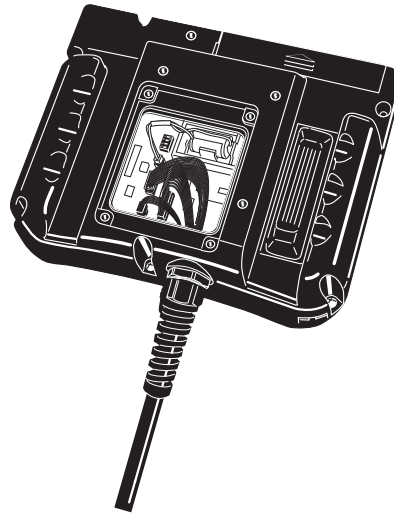

Be sure to correctly connect the connectors as shown in the following diagram.

- Serial interface: White, 20-pin connector
- 24-VDC power supply interface: Black, 3-pin connector
- External output interface: Black, 18-pin connector

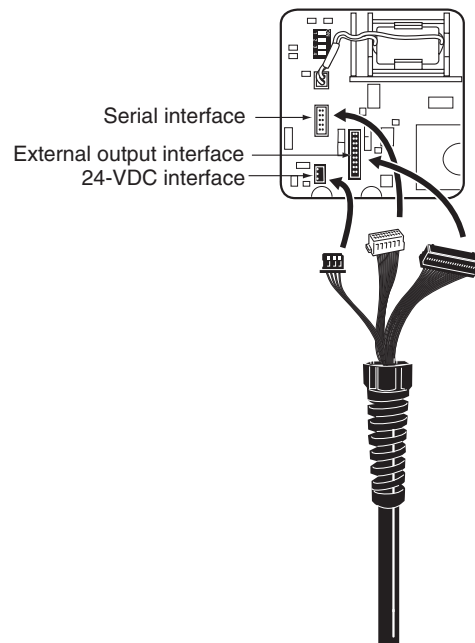

5. When using RS-422A communications, turn ON DIP switch pin 1 (terminating resistance ON) only when the PT is wired as the end communications node.

**Note** DIP switch pin 1 connects and disconnect the terminating resistance. Always turn OFF pins 2 to 4 (default setting).

6. First, use a tool to tighten the M screw shown in the following diagram to a force of 6.0 N to secure the cable to the PT.

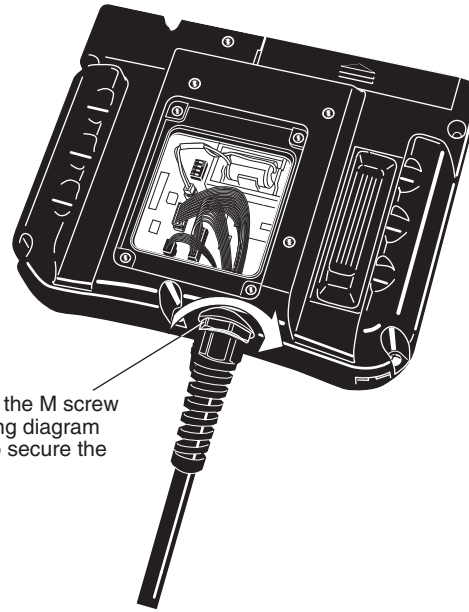

Use a tool to tighten the M screw shown in the following diagram to a force of 6.0 N to secure the cable to the PT.

7. Secure the cable to the PT with the cable bracket so that it will not come loose if pulled. Tighten the bracket with a torque of 6.0 N-m.

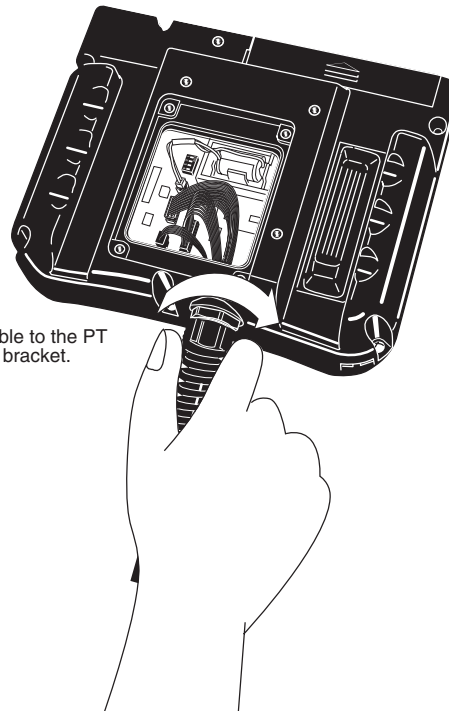

Secure the cable to the PT with the cable bracket.

8. Replace the cover, and tighten it with the four screws.

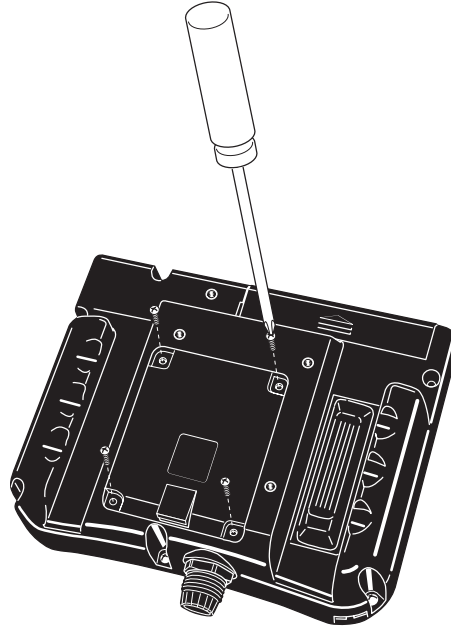

**Note** Tighten the screws to 0.4 N to secure the cover.

## 2-4 Attaching the Hand Strap

This section describes how to attach the hand strap to the PT.  
Please attach the hand strap when holding the PT during operation.

- 1,2,3... 1. There are two holes on the left side of the PT for attaching the hand strap. Pass both ends of the hand strap through the holes.

Pass both ends of the hand strap through the two holes.

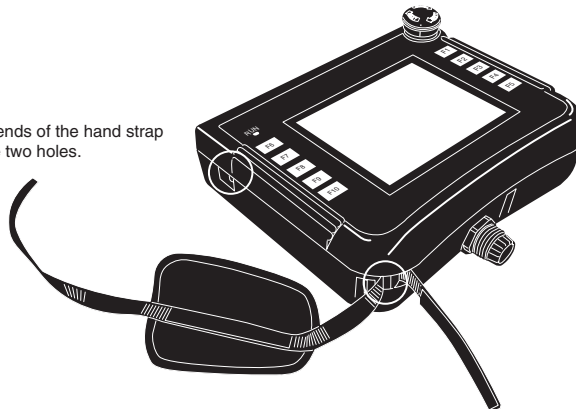

2. Pull the two ends of the hand strap together in the middle, and attach them using the Velcro strip.

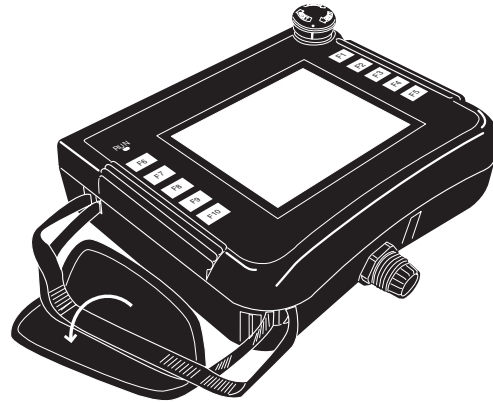

## 2-5 Installing the Mounting Bracket

- 1,2,3... 1. As shown below, there are two holes for installing the mounting bracket.

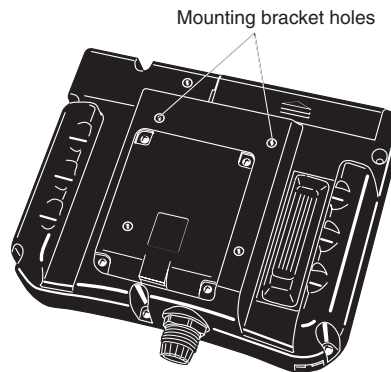

2. Secure the mounting bracket to the PT with the two screws.

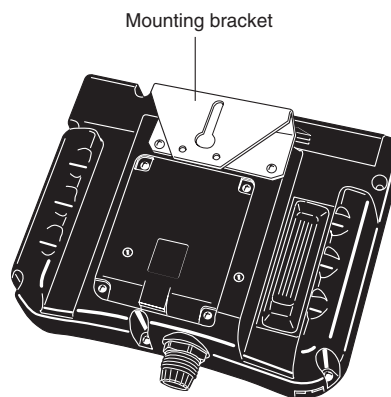

**Note** Tighten the screws to a force of 0.9 N.

3. Attach a screw or other support to the wall first and then hook the NSH5 on it to install it.

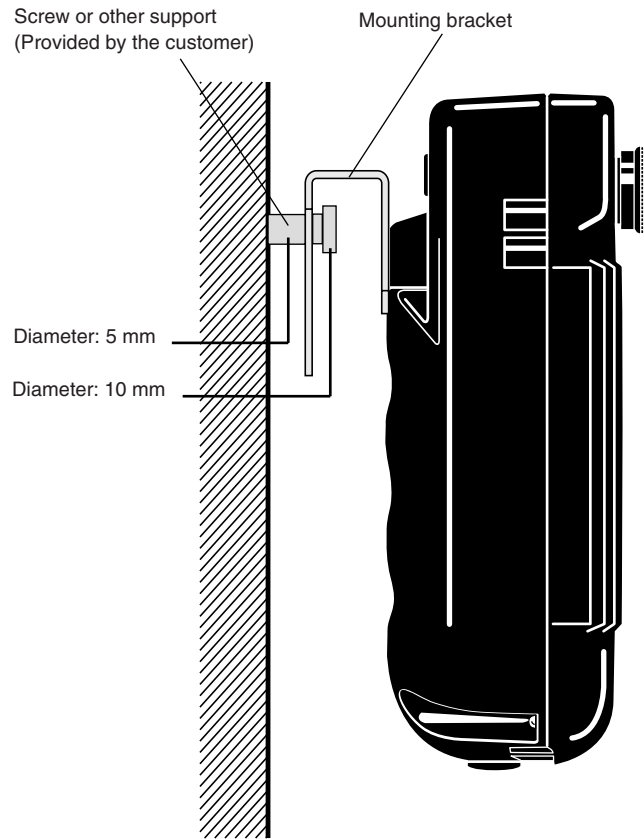

**Mounting the Visor**

The Visor prevents the emergency stop switch (or the stop switch) from turning ON should the PT fall forward when used in a non-mounted condition. Mount it as shown below, using screws on the top and rear surfaces.

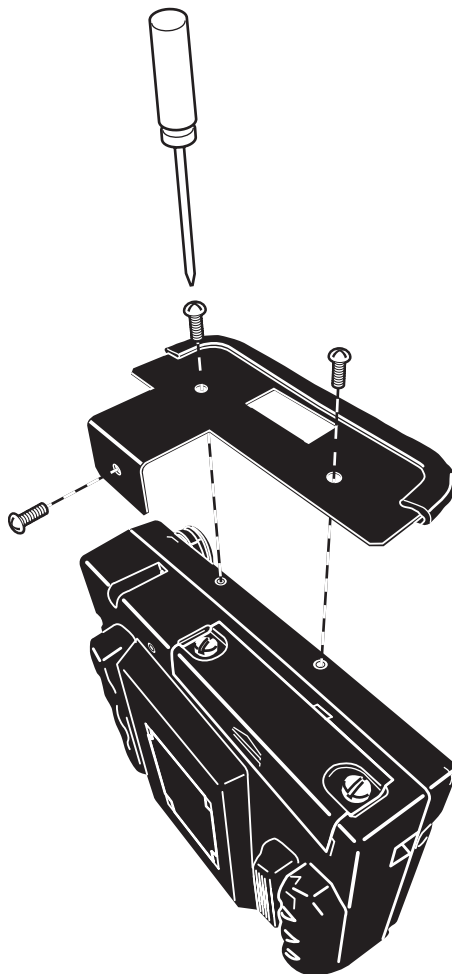

**Note** Tighten the screws to a force of 0.9 N.





# SECTION 3

## Functions

This section describes the functions that have been expanded or newly added to the NSH5 Programmable Terminal.

3-1	Creating Screen Projects . . . . .	38
3-2	Emergency Stop Switch . . . . .	38
3-3	Enabling Switch . . . . .	40
3-3-1	Overview . . . . .	40
3-4	Function Switches . . . . .	41
3-4-1	Overview . . . . .	41
3-5	Memory Cards . . . . .	42
3-5-1	Memory Card Applications . . . . .	42
3-5-2	Mounting and Removing Memory Cards . . . . .	43
3-5-3	Replacing the System Program . . . . .	44
3-5-4	Transferring Data with Memory Cards . . . . .	45
3-6	USB Port . . . . .	48
3-6-1	Connecting to the USB Port . . . . .	48
3-7	Screen Saver Prohibit Function . . . . .	48
3-8	Usable Host Connection Methods . . . . .	49
3-9	Station Detection Function . . . . .	50

### 3-1 Creating Screen Projects

Settings are required from the CX-Designer to use function keys with software notification (F3 to F5 and F8 to F10) or to obtain removable box station numbers. The settings for these functions are enabled when NSH5 screen projects are created using CX-Designer. To create new projects using CX-Designer, select the NSH5-SQ0□-V2 as the PT model.

An NSH5 screen project can be created using screen data created for an earlier PT. With the original screen project opened, it can be converted to an NSH5 screen project by selecting **Tool - Convert - Model** from the menu, and then selecting the NSH5-SQ0□-V2.

### 3-2 Emergency Stop Switch

The emergency stop switch can be used by workers to immediately stop the machine when an error occurs during operation or when a hazardous situation arises. The emergency stop switch has a DPST-NC contact structure for an external safety circuit. At the same time, a software condition (NO bit) can be used for internal or host notification, making the overall combined emergency stop switch a DPST-NC contact + NO bit switch.

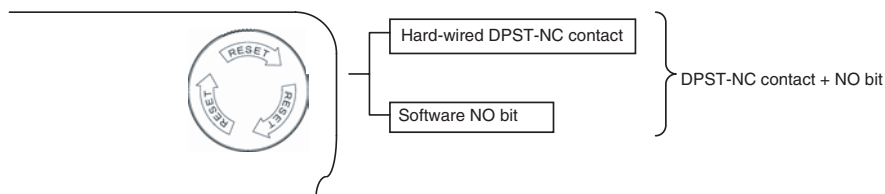

**Note** Use the software contact to monitor the emergency stop switch.

When the emergency stop switch is pressed to the lock position, as shown below, it will be turned OFF and locked. This prevents the switch from being turned OFF by being accidentally bumped, i.e., it will not operate unless it is pressed all the way to the lock position. An emergency stop can thus be executed only through a clear and intentional action. The lock is cleared by turning the button clockwise (in the direction of the RESET arrows).

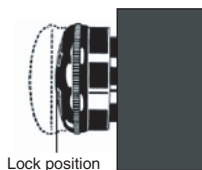

- Note**
- (1) When detaching and using the PT in a hand-held condition, use the NSH5-SQG00B-V2 (with grey switch). This functions as the stop switch and can be used in either the hand-held or mounted condition. When using the NSH5-SQR00B-V2 (with red switch), it functions as the emergency stop switch so the PT must be mounted and used on a control panel in a way that it cannot be detached. Both gray and red switches have the same switching function.
  - (2) The emergency stop must be enabled in all modes, and it must take highest priority over any other control operations. (ISO 13850, Item 4-1; IEC 60204-1, Item 9-2)
  - (3) An emergency stop switch must be located near each control panel or other operation site, and it must be accessible for rapid use in case of emergency. (ISO 12100-2, Item 3-7; ISO 13850, Item 4-4; and IEC 60204-1, Item 10-7)

(4) To ensure a secure stop, the stop category must be 0 or 1. (ISO 13850, Item 4-4; IEC 60204-1, Item 9-2)

**External Connection Diagram**

The status of the emergency stop switch's DPST-NC contact is output externally by hard-wired outputs via the Special Cable.

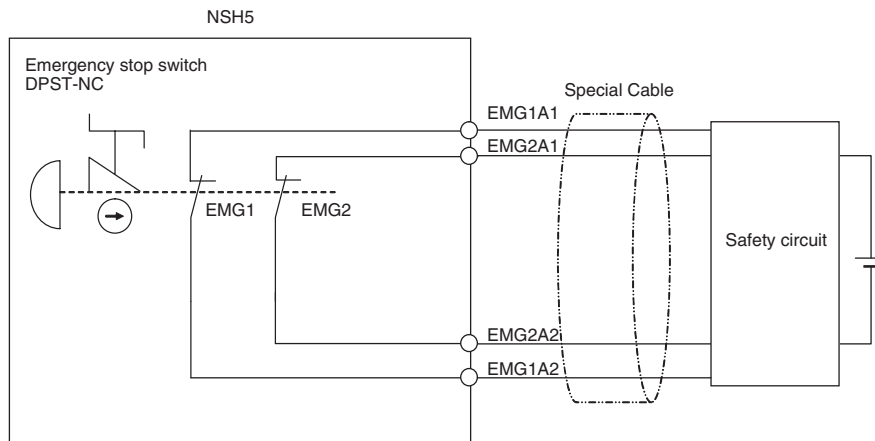

**Internal Memory or Host (PLC) Memory Allocation**

The emergency stop switch can be allocated any bit address in the internal memory or host (PLC) memory, and the ON/OFF status can be monitored at the allocated address.

To specify the address in internal memory or host (PLC) memory that is to be allocated to the emergency stop switch, first select **PT - System Setting** in CX-Designer and then click the **NS Handy Terminal** Tab. In the *Key Status Monitor Address* Field, click the **Set(1)** Button for *Emergency Stop (A)*, and specify the address to allocate.

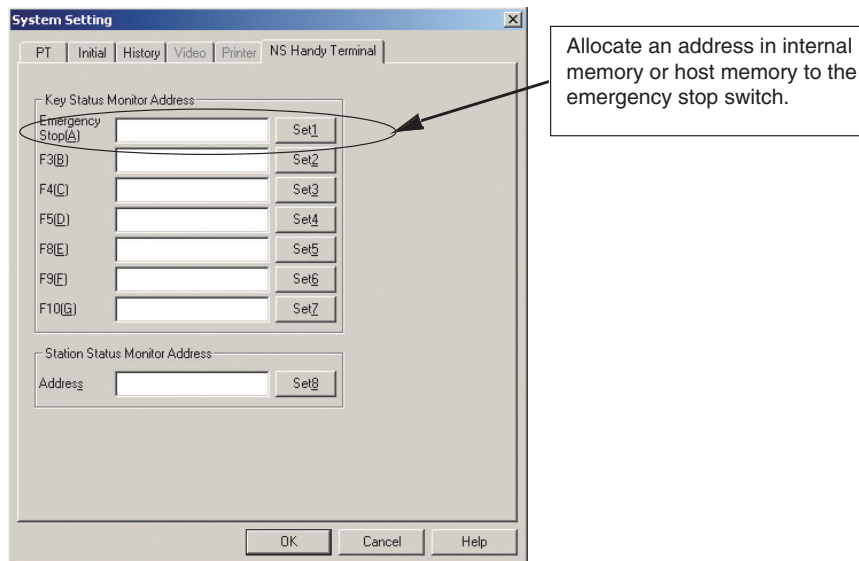

The following points apply to the emergency stop switch allocation.

- Only bit addresses can be set.
- Addresses can be set in either internal memory or host memory.
- System memory \$SB cannot be allocated.
- No address is allocated for the default setting.

The **NS Handy Terminal** Tab can be selected only when the PT model is set to the NSH5. It cannot be selected for any other PT model.

### 3-3 Enabling Switch

#### 3-3-1 Overview

In contrast to the emergency stop switch, which lets a worker intentionally stop the machine in case of an emergency, the enabling switch makes it easier to avoid danger with no conscious decision by a worker. When work is required in hazardous areas, e.g, during maintenance, devices with enabling switches provide an important safety measure by preventing unexpected operations from occurring while work is underway in the those areas.

Manual operation of devices is permitted while the enabling switch is lightly pressed. At soon as a hazardous situation arises, however, operation is stopped if the worker instinctively either lets go of the enabling switch or grasps it more tightly.

Some standards, such as the ANSI/RIA R15.06 and CSA/Z434-03 Industrial Robot Standards and the ANSI/B11.19 Machine Tool Standards, require the use of enabling switches. In EN 60204-1, enabling switches are not required but are recommended as auxiliary devices.

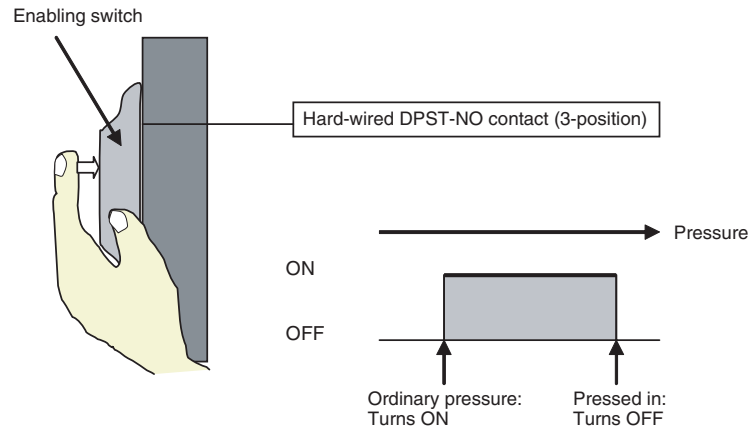

#### External Connection Diagram

The status of the enabling switch's DPST-NO contact is output externally using a hard-wired output from the Special Cable.

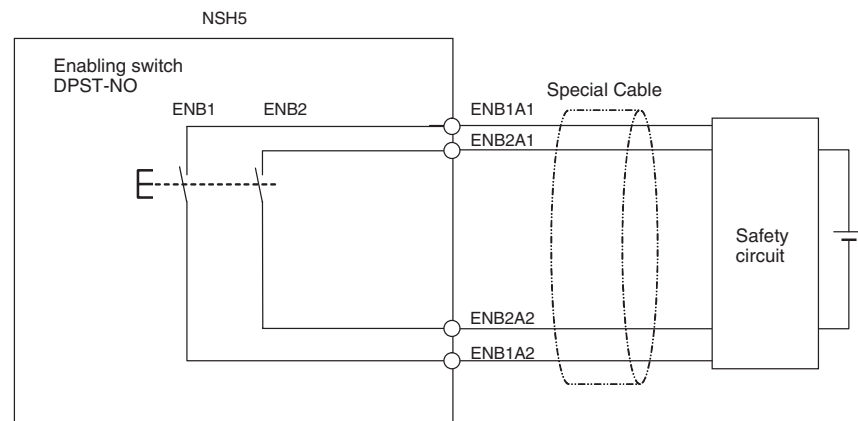

### 3-4 Function Switches

#### 3-4-1 Overview

The NSH5 has ten function switches, and the status of these switches can be sent to hard-wired outputs or to internal memory or host (PLC) memory.

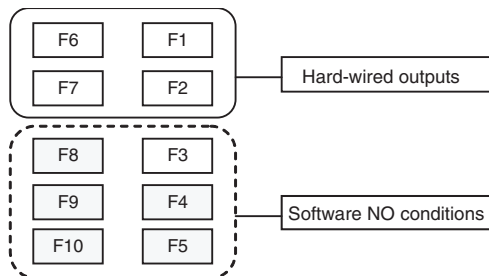

The status of function switches F1, F2, F6, and F7 is output externally by hard-wired outputs via the Special Cable. The status of the six remaining switches (F3, F4, F5, F8, F9, and F10) are output to internal memory or host (PLC) memory.

#### External Connection Diagram

The status of function switches F1, F2, F6, and F7 are output externally by hard-wired outputs via the Special Cable.

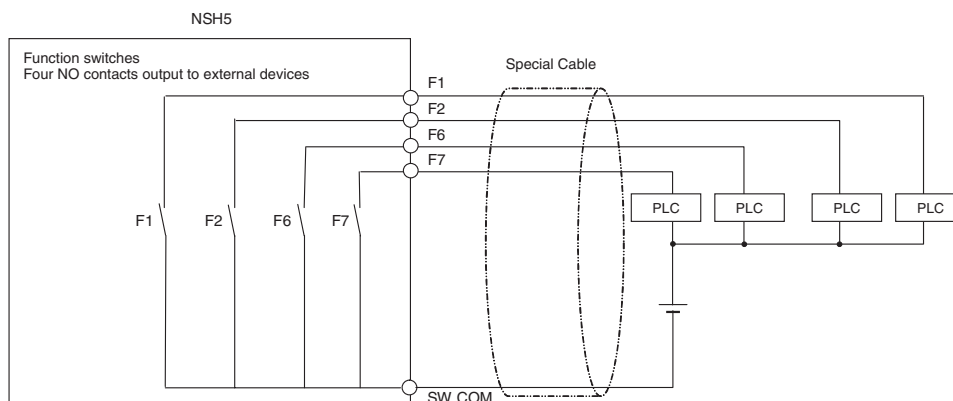

#### Internal Memory or Host (PLC) Memory Allocation

NSH5 function switches F3 to F5 and F8 to F10 can be allocated any bit addresses in the internal memory or host (PLC) memory, and their ON/OFF status can be monitored at the allocated address.

To specify the address in internal memory or host (PLC) memory that is to be allocated to a function switch, first select **PT - System Setting** in CX-Designer and then click the **NS Handy Terminal** Tab. In the *Key Status Monitor Address* Field, click the appropriate **Set** Button, and specify the address that is to be allocated.

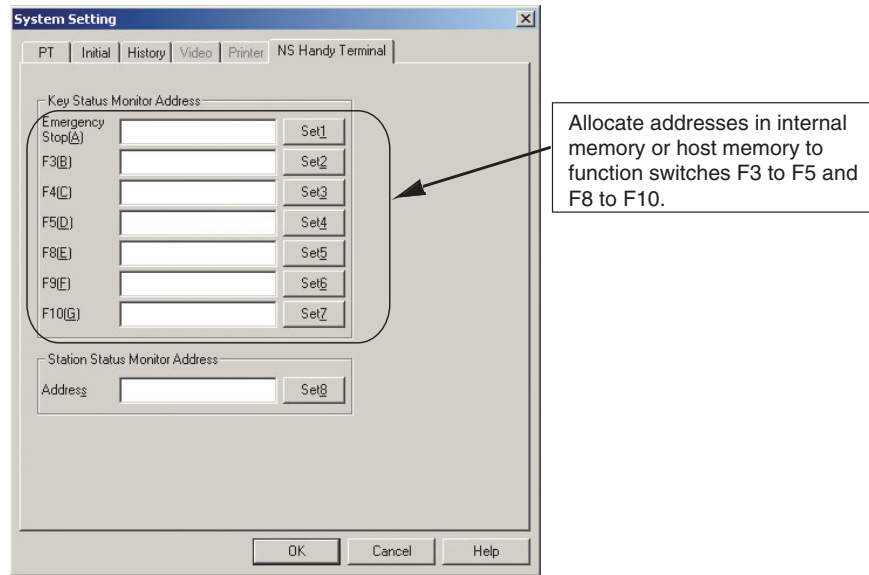

The following points apply to the function switch allocations.

- Only bit addresses can be set.
- Addresses can be set in either internal memory or host memory.
- System memory \$SB cannot be allocated.
- No address is allocated for the default setting.

The **NS Handy Terminal** Tab can be selected only when the PT model is set to the NSH5. It cannot be selected for any other PT model.

## 3-5 Memory Cards

Memory Cards are used for storing and transferring screen data, log data, and system programs. This section provides an overview of Memory Card functions. Refer to the *NS-Designer Operation Manual* (Cat. No. V074-E1) for details on Support Software transferring methods.

### 3-5-1 Memory Card Applications

Memory Cards can be used at the PT itself. Log files can be saved to a Memory Card as CSV files. There are four kinds of log files, as shown in the following table.

Alarm/event history	Stores alarm/event history data that has been registered by CX-Designer.
Data log	Stores trend data.
Operation log	Stores screen operation log data.
Error log	Stores error log data for when macros are executed.

Log data is normally saved in internal memory that is backed up in the PT, but can also be saved in CSV file format. When log data is saved as a CSV file, it is stored on the Memory Card. The CSV files containing log data are saved in the log folder created in the Memory Card.

The following data can be transferred using a Memory Card.

- System programs (programs required for operating the PT, such as for communications and fonts)

- Screen data (data used in the PT display)

The transfer method is manual transfer (i.e., the data to be transferred and the transfer direction are selected manually), and operations are specified from the System Menu.

**Note** There are four recommended Memory Card models, each of which, has a different capacity.

HMC-EF372	30 MB	Flash memory
HMC-EF672	64 MB	Flash memory
HMC-EF282	256 MB	Flash memory
HMC-EF582	512 MB	Flash memory

A Memory Card can be overwritten approximately 100,000 times. When using a PC card socket in devices such as notebook computers, use an HMC-AP001 Memory Card Adapter.

## 3-5-2 Mounting and Removing Memory Cards

### Mounting a Memory Card

- 1,2,3...**
1. As shown below, to mount the Memory Card to the Memory Card interface first loosen the two screws securing the cover on the top of the PT.

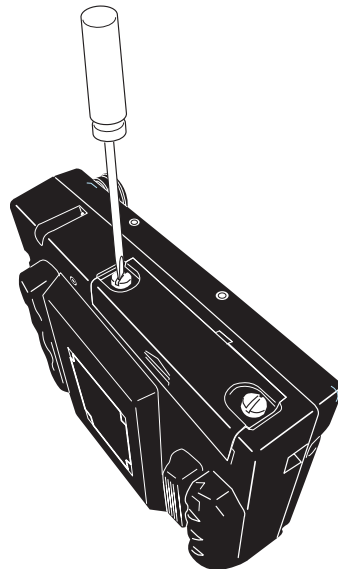

2. After the screws have been removed, open the cover by pulling it up and forward with a finger.

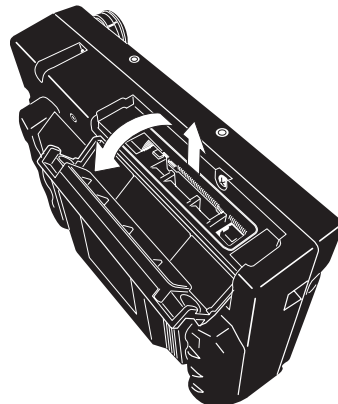



3. Insert the Memory Card all the way in. (As this is done, the eject button will pop out.)

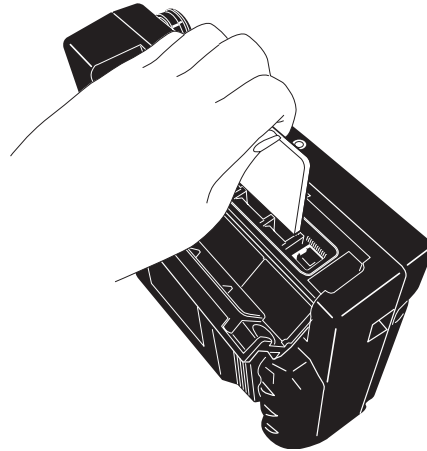

**Note** Tighten the cover to a force of 0.9 N.

**Removing a Memory Card** Press the eject button to remove the Memory Card. To prevent the Memory Card from popping out and falling, hold the Memory Card with your index finger while pushing the eject button with your middle finger.

### 3-5-3 Replacing the System Program

The system program in the PT can be replaced or upgraded to a higher version. There are two methods that can be used to replace the system program.

- Using a recovery/upgrade program
- Transferring system program data

#### Using a Recovery/Upgrade Program

Use the following procedure to replace the system program if the system program becomes corrupted and the PT will not start or to upgrade the system program in the PT.

- 1,2,3... 1. Copy all of the files and folders in the RecoverUpdate\_□\_□ folder inside the CX-Designer installation folder (default: C:\ProgramFiles\Omron\CX-One\CX-Designer) to a Memory Card. This program can be selected when installing the CX-Designer.  
(“□\_□” will be replaced by numbers indicating the system program version. For example “RecoverUpdate\_7\_0” is the file for version 7.0.)
2. Insert the Memory Card into the PT and turn ON the power supply. The recovery/update program will start automatically.
3. The indicator will flash green when the download has been completed normally.

**Note** For details on the recovery/update program, select **Start - Program - OMRON - CX-One - CX-Designer - How to recover the system prog Ver. 7.0.**

#### Transferring System Program Data

The System Program is stored under the CX-Designer's install folder (default location is C:\Program Files\Omron\CX-One\CX-Designer) in folders that are created for each type and version, as follows:

\SystemBackup\NSH5\V□\_□\bank1: NSH5 system program  
(“□\_□” will be replaced by numbers indicating the system program version. For example “RecoverUpdate\_7\_0” is the file for version 7.0.)

To replace a system program, use Windows Explorer or another method to copy each of the folders for the required system program under \bank1 to the route directory of the Memory Card.

For details on methods for transferring data from the Memory Card to the PT, refer to *3-5-4 Transferring Data with Memory Cards*.

The system backup folder can be created only if CX-Designer is installed from the stand-alone CD-ROM. If the CX-Designer is installed from CX-One, re-install the system program by following the procedure for using a recovery/update program described above.

### 3-5-4 Transferring Data with Memory Cards

Using a Memory Card with the PT allows system programs (programs required for operating the PT, such as programs for communications and fonts) and screen data to be transferred to and from the PT.

There are several types of data transfers, including manual transfers (in which the data to be transferred and the direction of transfer are selected manually), downloads (in which data is transferred automatically from the Memory Card to the PT), uploads (in which data is transferred automatically from the PT to the Memory Card), and bank specifications (four banks max.). The transfer method is specified using the System Menu.

- Note**
- (1) Before transferring data, check to be sure that the system programs and screen data types match those in the PT.
  - (2) Do not perform the following operations while accessing the Memory Card. The data may be damaged and the Memory Card may need to be formatted.
    - Turning OFF the power to the PT.
    - Removing the Memory Card.

Always follow the correct procedure for removing a Memory Card.

If the PT system has been damaged due to the power being turned OFF while a file is being written, it may not be possible to use normal downloading to replace a system program. If this situation occurs, refer to *Troubleshooting* below.

#### Manual Transfer

Use screen operations to select the transfer direction (download, upload), contents (project, project & system program, or system program), and banks. Use the following procedure to manually transfer data.

- 1,2,3...**
1. Turn ON the power to the PT.
  2. Insert the Memory Card into the PT.
  3. Simultaneously press two of the four corners of the PT touch panel to display the System Menu Screen.
  4. Display the Special Screen Tab Page under system settings, and execute Memory Card transfer on page 2-2 of the screen.

- Select the display language. The following screen will be displayed at the PT if English is the language selected.

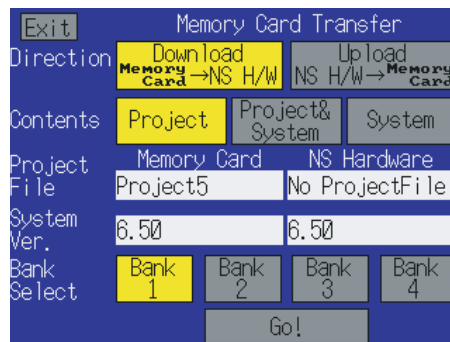

- Specify the transfer direction (download, upload), contents (project, project & system program, or system program), and bank. The IPP file name and system version that are stored in both the specified bank of the Memory Card and the PT will be displayed in the *Project File* and *System Version* fields.
- Check the contents, and press the **Go!** Button. A message asking for confirmation of the transfer will be displayed.
- Press the **Yes** Button to execute the specified data transfer operation. When data is downloaded, the screen data previously stored in the PT will be deleted.
- A warning message will be displayed if the PT model, system program, screen data version, or language for the language stored in the PT are different from that for the data stored in the Memory Card. Press the **Yes** Button to continue the data transfer.
- While the data is being transferred, an uploading or downloading screen will be displayed. A screen indicating that the transfer has been completed will be displayed when the data transfer is finished. (If an error occurs, a transfer error screen will be displayed. If that occurs, refer to *Troubleshooting* below.)
- The indicator will flash green when the data transfer has been completed. At this point the Memory Card can be removed.
- Press the **Reset** Button to reset the PT.

If the wrong data is downloaded, execute the transfer operation again.

The system settings (set in the *System Setting* using the CX-Designer) are not changed for the upload operation.

### Troubleshooting

If an error occurs while data is being transferred, a transfer error screen will be displayed. Check the following items for the messages that are displayed.

Error message	Items to check
Memory Card Error Could not recognize the Memory Card. Check the Memory Card and reset the PT.	Is a Memory Card inserted into the PT? Is the Memory Card damaged?
Project Transmission Error Transmission failed. Check the Memory Card and reset the PT.	Was the Memory Card removed during data transfer? Is there insufficient free space on the Memory Card?
System Transmission Error Transmission failed. Check the Memory Card and reset the PT.	Is the Memory Card damaged? Does the screen volume exceed the memory capacity of the PT?

Error message	Items to check
Project Transmission Error The project cannot be transferred because it does not match.	Do the NS-series, NSH-series, and NSJ-series projects, systems, and PT models match for the transmission source and destination?
System Transmission Error The system cannot be transferred because the hardware does not match.	
Cannot find source data. Continue downloading/uploading?	Does the transfer source directory or file exist? (Note: If the Yes Button is pressed and data is transferred, the previous data at the transfer destination will be deleted.)

After checking the message, reset the PT and transfer the data again. If the PT system has been damaged due to the power being turned OFF while a file is being written, it may not be possible to use normal downloading to replace a system program.

If the system program cannot be replaced or has been corrupted, and the PT will not start, refer to *3-5-3 Replacing the System Program* and replace the system program using the information provided there.

## 3-6 USB Port

The USB port can be used to transfer screens created by the CX-Designer. For details, refer to the *NS Series Setup Manual* (Cat. No. V083-E1).

### 3-6-1 Connecting to the USB Port

Open the cover on top of the PT, as shown in the following diagram, and connect a commercially available USB cable to the USB port. (For details on opening the cover, refer to *3-5 Memory Cards*.)

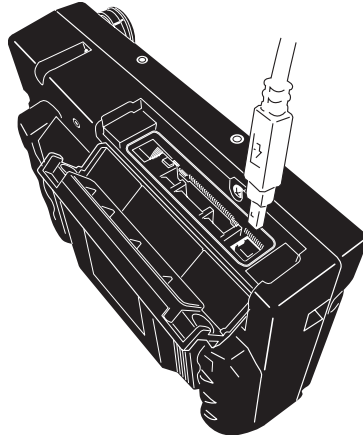

## 3-7 Screen Saver Prohibit Function

A screen saver must be set, but the screen saver prohibit function allows the screen saver to be prohibited by an external control. Adding this function has made it possible for screen saver operation to be prohibited by means of \$SB even when the screen saver has been set to operate.

### Setting Method

The screen saver will be disabled when \$SB53 is ON.

If the screen saver is set to operate, then the time count until the screen saver starts is reset when \$SB53 turns OFF (just as if the screen had been touched at that point). \$SB53 is displayed when the screen saver is turned OFF.

\$SB53 is included in the \$SB list (Expansion 2/2) under the **Initial** Tab in the System Setting Menu. The default for \$SB53 is OFF.

**Relationship between \$SB9 and \$SB53**

When the screen saver is set to operate, \$SB9 (Backlight Control) is linked to the screen saver function. Therefore, when the screen saver is prohibited by \$SB53 from starting, \$SB9 operation is affected as well. The relationship between \$SB9 and \$SB53 is shown in the following tables.

Conditions: Screen saver set to operate (starting time: 1 min)

\$SB53	\$SB9 change	Operation
OFF	OFF to ON	Screen saver starts after 3 s.
	ON to OFF	Screen saver cleared.
ON	OFF to ON	Screen continues to be displayed.
	ON to OFF	Screen continues to be displayed.

\$SB9	\$SB53 change	Operation
OFF	OFF to ON	Screen continues to be displayed.
	ON to OFF	Screen continues to be displayed. Screen saver starts after 1 m.
ON	OFF to ON	Screen saver cleared (screen displayed) to \$SB9 turns OFF.
	ON to OFF	Screen saver starts after 3 s.

- Note**
- (1) \$SB9 can be used to start the screen saver, so the backlight is not cleared by changes in \$SB9 ON/OFF status while \$SB53 is ON.
  - (2) When the screen saver is set not to operation, the screen saver will still start 3 seconds after \$SB9 is turned ON regardless of the ON/OFF status of \$SB53. While \$SB9 is ON (i.e., while the screen saver is operating), the screen saver will not be cleared even if \$SB53 is turned ON.

## 3-8 Usable Host Connection Methods

The NSH5 has one serial port corresponding to serial port A in the NS Series, for connecting to the PLC. Unlike with the NS Series, it is not possible to connect using serial port B, the Ethernet port, or Controller Link. When using CX-Designer to set the connection method, do not set any communications ports other than serial port A.

The communications methods shown in the following table can be set, using the serial port.

Host connection method	Usability
1:N NT Link	OK (See note 1.)
1:1 NT Link	OK
Host Link	OK (Host Link OK with restrictions) (See note 2.)

- Note**
- (1) Only one NSH5 can be connected to any one communications port on the PLC. More than one PT cannot be connected at the same time.
  - (2) Only PT memory can be allocated as the notification destination for the emergency stop switch and function switches F3 to F5 and F8 to F10. Host allocations are not possible.

### 3-9 Station Detection Function

The station detection function allows the NSH5 to read the box number switches (4-bit switches) for removable boxes. Thus, when a removable box is connected, the NSH5 is able to detect it.

By automatically displaying station screens, and by giving notification of which station the PLC is currently in, the stations that can be operated can be limited. To ensure safety, other forms of operation are disabled.

#### Internal Memory Allocation

The PT's station detection function can be allocated any address in the internal memory, and the ON/OFF status can be monitored at the allocated address.

To specify the address in internal memory that is to be allocated for the station status monitor address, first select **PT - System Setting** in CX-Designer version 6.5 or higher, and then click the **NS Handy Terminal** Tab. In the *Station Status Monitor Address* Field, click the appropriate **Set** Button, and specify the address that is to be allocated.

When removable boxes are used, the station numbers for the removable boxes are acquired and notification is provided to one word in either \$W or \$HW in PT memory. If function key status cannot be obtained due to a problem, such as a hardware error, or when a status error flag for an error, such as a communications error, is generated, notification is provided to the same word.

Bit allocations within the word is as follows:

Bit	Name	Status
Bit 15	Board Error Bit	ON: Error
Bit 14	Host Communications Error Bit	OFF: Normal
Bit 13	Reserved	---
Bit 12	Reserved	---
Bit 11	Reserved	---
Bit 10	Reserved	---
Bit 9	Reserved	---
Bit 8	Reserved	---
Bit 7	Reserved	---
Bit 6	Reserved	---
Bit 5	Reserved	---
Bit 4	Reserved	---
Bit 3	S4 (Station ID line 4 signal status)	0: Not connected 1 to 15 (binary format): Station number
Bit 2	S3 (Station ID line 3 signal status)	
Bit 1	S2 (Station ID line 2 signal status)	
Bit 0	S1 (Station ID line 1 signal status)	

Any number from 1 to 15 can be set for a station box. For station number switches, wire station ID line signals S1 to S4 in relation to the station numbers as shown in the following table.

	Not connected	Station number														
		1	2	3	4	5	6	7	8	9	10	11	12	13	14	15
S4	0	0	0	0	0	0	0	0	1	1	1	1	1	1	1	1
S3	0	0	0	0	1	1	1	1	0	0	0	0	1	1	1	1
S2	0	0	1	1	0	0	1	1	0	0	1	1	0	0	1	1
S1	0	1	0	1	0	1	0	1	0	1	0	1	0	1	0	1

1: Signal level ON, 0: Signal level OFF

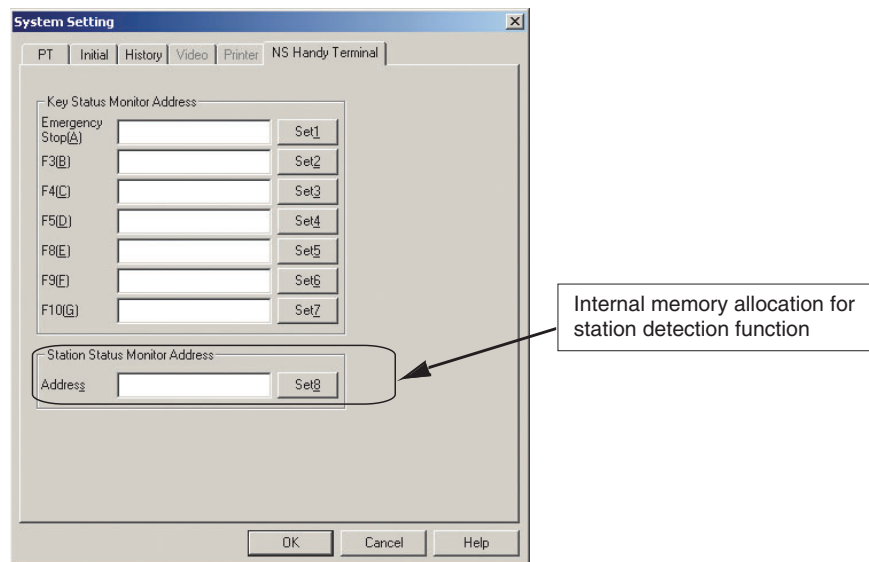

The following points apply to the allocation for the station detection function.

- Only word addresses can be set.
- Addresses can be set in either internal memory only.
- System memory \$SW cannot be allocated.
- No word address is allocated in the default setting.

The **NS Handy Terminal** Tab can be selected only when the PT model is set to the NSH5. It cannot be selected for any other PT model.





# SECTION 4

## Connecting to the Removable Box

This chapter describes the Removable Box, which is connected to the NSH5.

4-1	Overview of Removable Box .....	54
4-2	Nomenclature and Functions .....	54
4-3	Switch Settings .....	56
4-4	Installation .....	58
4-5	Connection Method .....	60

## 4-1 Overview of Removable Box

An NSH5-AL001 Removable Box can be connected between the NSH5-SQG00B-V2 PT (the model with a gray stop switch) and the host PLC to enable easily attaching and detaching the NSH5 without affecting the wiring to the PLC or safety circuits. The Removable Box also enables converting between RS-232C and RS-422A.

The Removable Box is equipped with a rotary switch to set the station number used to identify the Removable Box and a DIP switch for setting RS-422A communications conditions.

### System Configuration

The NSH5 PT is connected to a PLC through the Removable Box. Always use an NSH5-232CN-3M/10M Special Cable to connect the NSH5 PT to the Removable Box.

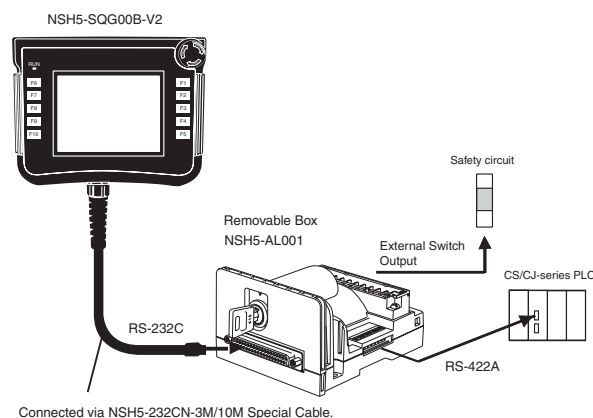

- Note**
- (1) Always turn OFF the key switch before connecting or disconnecting the Cable using the Removable Box.
  - (2) Always use the Removable Box connected to the NSH5-SQG00B-V2 PT (the model with a gray emergency switch).

## 4-2 Nomenclature and Functions

This section describes names and function of the components of the Removable Box.

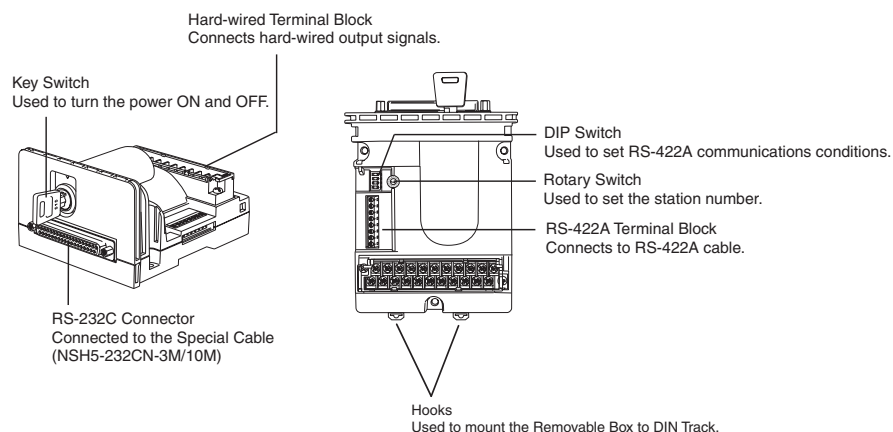

Terminal block and connector pin arrangement details are shown below.

RS-422A Connector

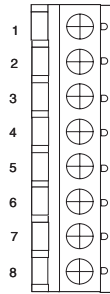

Pin No.	Signal	Contents
1	RDB+	Receive Data B
2	RDA-	Receive Data a
3	SDB+	Send Data B
4	SDA-	Send Data A
5	RSA-	Request Send A
6	RSB+	Request Send B
7	SG	0 V
8	FG	Frame ground

RS-232C Connector

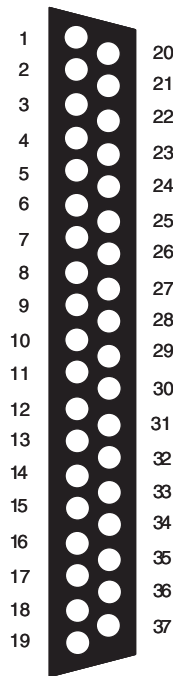

Pin No.	Signal	Contents
1	S1	Station ID line 1
2	S2	Station ID line 2
3	0 V (SG)	Station ID line 0 V
4	CONNECT1	Cable Connection Confirmation Line
5	NC	Not connected
6	RD	Receive Data
7	SD	Send Data
8	NC	Not connected
9	SWCOM	Function switch common
10	F6	Function switch F6
11	F1	Function switch F1
12	NC	Not connected
13	ENB1A1	Enabling switch line 1
14	ENB2A1	Enabling switch line 2
15	EMG1A1	Emergency stop switch line 1
16	EMG2A1	Emergency stop switch line 2
17	NC	Not connected
18	0 V	0-V Power Supply Input
19	24 V	+24-V Power Supply Input
20	S3	Station ID line 3
21	S4	Station ID line 4
22	CONNECT2	Cable Connection Confirmation Line
23	NC	Not connected
24	0 V (SG)	Secondary Ground
25	RS	Request Send
26	CS	Clear to Send
27	NC	Not connected
28	NC	Not connected
29	F7	Function switch F7
30	F2	Function switch F2
31	NC	Not connected
32	ENB1A2	Enabling switch line 1
33	ENB2A2	Enabling switch line 2
34	EMG1A2	Emergency stop switch line 1
35	EMG2A2	Emergency stop switch line 2
36	NC	Not connected
37	FG	Frame ground

**Hard-wired Terminal Block**

Be sure the wires connected to the hard-wired output terminals have a total length of no more than 3 meters.

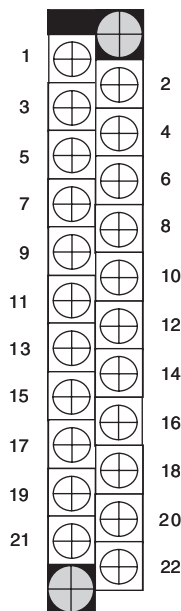

Pin No.	Signal	Contents
1	NC	Not connected
2	NC	Not connected
3	CONNECT1	Cable Connection Confirmation Line
4	CONNECT2	Cable Connection Confirmation Line
5	F1	Function switch F1
6	F2	Function switch F2
7	F6	Function switch F6
8	F7	Function switch F7
9	SWCOM	Function switch common
10	ENB1A1	Enabling switch line 1
11	ENB1A2	Enabling switch line 1
12	ENB2A1	Enabling switch line 2
13	ENB2A2	Enabling switch line 2
14	EMG1A1	Emergency stop switch line 1
15	EMG1A2	Emergency stop switch line 1
16	EMG2A1	Emergency stop switch line 2
17	EMG2A2	Emergency stop switch line 2
18	ENB-CH1	Key Switch Confirmation Signal Line
19	ENB-CH2	Key Switch Confirmation Signal Line
20	24 V	+24-V power supply input
21	0 V	0-V power supply input
22	FG	Frame ground

**CONNECT1/2:** These signal lines are used to confirm that the NSH5 Cable is connected to the Removable Box. Attaching the connector will short the CONNECT1 and CONNECT2 pins. When using a PLC I/O Unit, use these signal lines to confirm the connection.

**ENB-CH1/2:** These signal lines are used to confirm the key switch condition when using the NSH5 in Teaching Mode. If the key switch is turned ON, the internal relay is turned ON, which will short the ENB-CH1 and ENB-CH2 pins. Use these signal lines when using the enabling switch as described in *Appendix E Recommended Enabling Circuits*.

### 4-3 Switch Settings

**Key Switch**

Power to the Removable Box is turned ON and OFF with the key switch. The power is OFF when the key is in the vertical position. (Refer to the diagram below.)

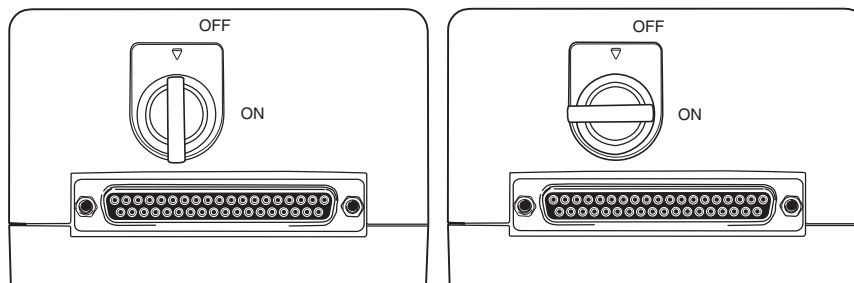

**Note** Always turn OFF the key switch before connecting or disconnecting the Cable using the Removable Box.

**DIP Switch**

The DIP switch is used to set RS-422A communications conditions. Set the DIP switch before connecting the cable to the Removable Box.

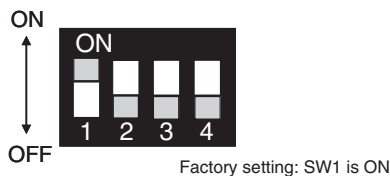

Pin No.	Description	ON	OFF
1	Built-in terminating resistance setting	Terminating resistance is connected.	Terminating resistance is not connected.
2, 3	Do not change these settings.	---	---
4	RS-422A transmission mode setting	RS-232C CS control	Always send

**Note** When using a single NSH5 PT, turn OFF pin 4 (always send). When using more than one NSH5 PT, turn ON pin 4 (RS-232C CS control).

In station detection mode, use the rotary switch to set a station number between 1 and 15 for the Removable Box. Set this switch before connecting any cables to the Removable Box. (Station number 0 means that the Removable Box is not connected.) For details on the station detection function, refer to 3-9 Station Detection Function.

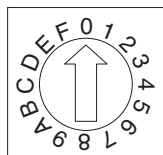

Station number	0	1	2	3	4	5	6	7	8	9	10	11	12	13	14	15
Rotary switch	0	1	2	3	4	5	6	7	8	9	A	b	C	D	E	F

**Note** Always turn OFF the Removable Box's key switch before setting the DIP switch or the rotary switch.

# 4-4 Installation

## Dimensions

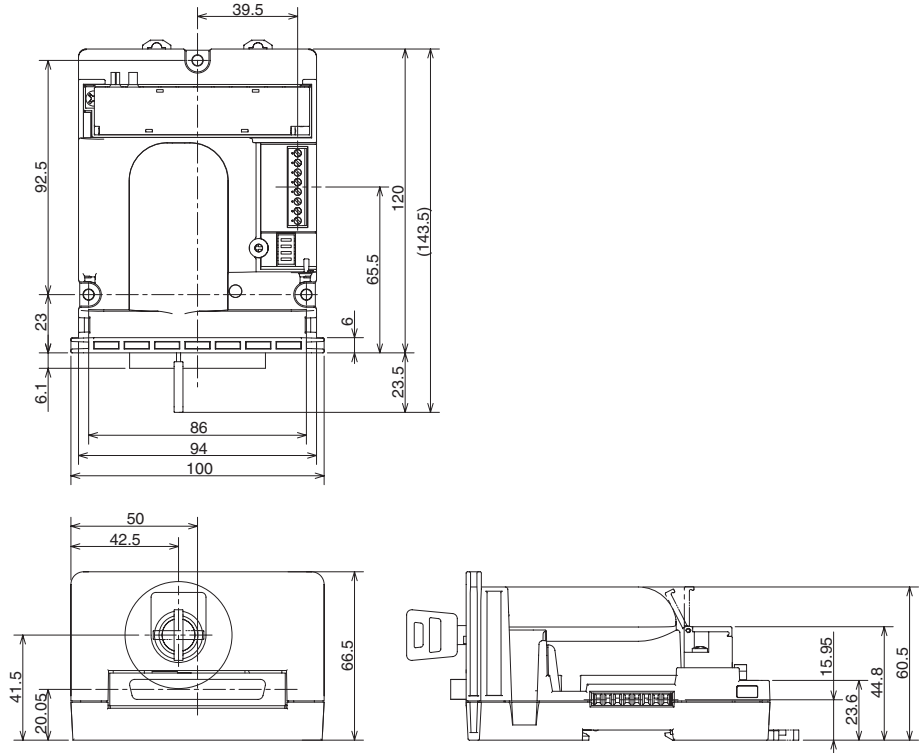

The Removable Box can be installed using any of the following three methods.

### Mounting to a Panel

To mount the Removable Box on a panel, use the mounting brackets and tool (Phillips screwdriver) that are included in the package.

**Note**

- (1) Do not allow metal particles to enter the Removable Box while work is being done on the panel.
  - (2) The mounting panel must be between 1.6 and 4.8 mm thick.
  - (3) Secure the mounting brackets with a uniform tightening torque of 0.5 to 0.6 N·m. Use a panel that is clean, undistorted, and strong enough to adequately support the Removable Box.
  - (4) Do not use the Removable Box in environments that require water resistance or oil resistance.
1. Refer to the cutout dimensions in the following diagram and cut out a hole for embedding the Removable Box, Then insert the Removable Box from the front side of the panel.

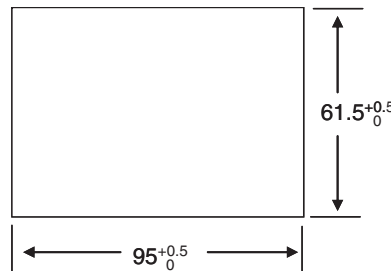

2. As shown in the following diagram, attach the mounting brackets to the Removable Box mounting holes or slots (3 places).

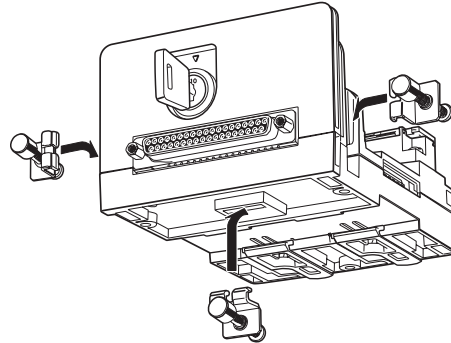

3. From the back of the panel, hold the Removable Box to pull the mounting brackets toward you and tighten the mounting bracket screws to secure the Removable Box.

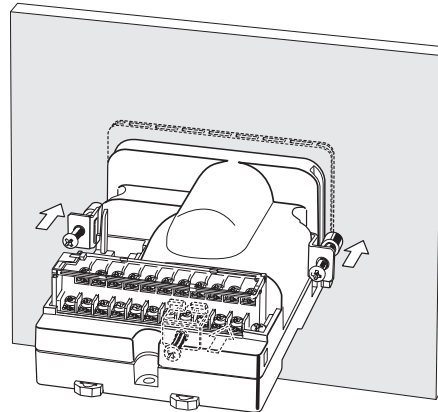

**Mounting to a DIN Track**

Catch the upper hook on the back of the Removable Box on the DIN Track, and push in the direction of the arrow and secure the Removable Box with the bottom latch. Attach End Plates to the right and left of the Removable Box so that it does not shift in either direction

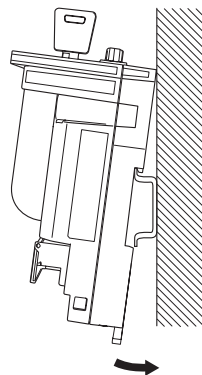

**Note** When mounting the Removable Box on a DIN Track, be sure to secure the cable so that no load is placed on the connector. The Removable Box or DIN Track may be damaged if the cable places a load on the connector.



**Removing from a DIN Track**

Remove the End Plates, and then insert a screwdriver in the hooks on the base of the Removable Box and pull down.

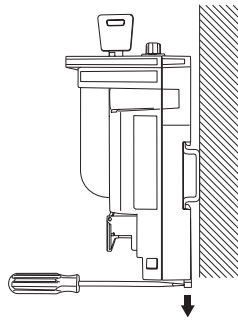

**Mounting to a Panel**

Referring to the dimensions in the following diagram, cut three holes in a panel with a minimum thickness of 2 mm. Secure the Removable Box to the panel with screws using the screw (4M × 14) mounting holes on the Removable Box.

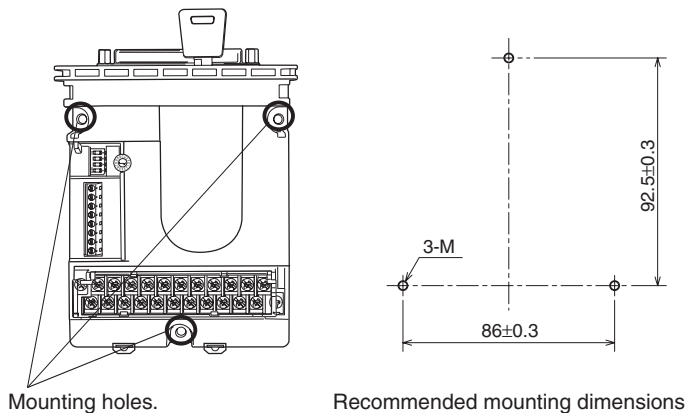

Mounting holes.

Recommended mounting dimensions

**Note** To ensure that the Removable Box is mounted securely, use a panel with a thickness of at least 2 mm.

## 4-5 Connection Method

The Removable Box is connected between the NSH5 PT and a PLC.

**Precautions Prior to Wiring**

Check the following items prior to wiring.

- Signal Lines  
Make sure that the PLC's I/O are correct.
- NSH5 Special Cable Connector  
Make sure that the NSH5 Special Cable connector screws and the Removable Box are securely locked.
- Hard-wired Terminal Block  
The hard-wired terminal block is removable. Make sure it is securely connected and that all screws are tight.
- RS-422A Terminal Block  
Make sure that all I/O lines between the PLC and the Removable Box are correct.
- NSH5 Unit Number Setting  
When using more than one NSH5 PT, make sure in advance that no unit numbers are used more than once. If duplicate numbers exist, a communications error will occur.

RS-422A Wiring

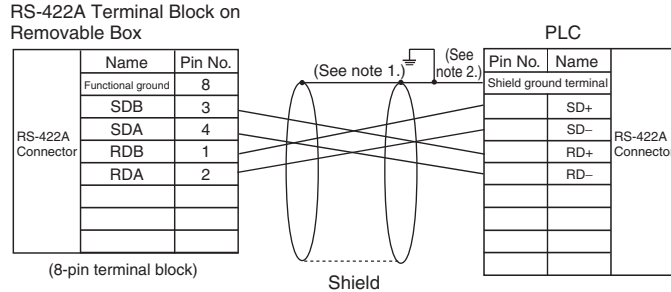

Use twisted-pair wires for SDB and SDA, and for RDB and RDA

- Note**
- (1) Ground the shield only to the host (PLC) to prevent malfunctions due to ground potential differences.
  - (2) Recommended cables: TKVBS4P-03 (100 m Tachii Electric Wire) or AWG22 shielded cable.

Ground and Shield Wiring

Perform the following connections, shield wiring, and grounding in any communications system using the Removable Box. Incorrect connections may cause a host communications error.

• **Connecting the Removable Box D-Sub Connector**

Be sure to fasten the screws on both sides of the D-Sub connector. If these screws are not fastened, the NSH5 PT's functional ground terminal and the Removable Box's FG will not be connected.

• **Ground Line Wiring**

The Removable Box is equipped with a functional ground (⏏).

1. Normally, ground the Removable Box as shown in *Figure A* on the following page.

- Connect the ground terminals on all Units and the functional ground, and ground the line at one location to 100 Ω or less.
- Short the PLC's LG terminal and the GR terminal.
- The ground wire must be 2 mm<sup>2</sup> or larger.
- For detailed grounding instructions, refer to the operation manual for the Communications Unit.

2. If a source of noise, such as a motor or inverter, is grounded to the same panel, do not ground the Removable Box's functional ground terminal (⏏), as shown in the *Figure B*.

• **RS-422A Cable Shield Wiring**

Be sure to connect the shield on the RS-422A cable. If the shield is not connected, a host communications error may occur.

When connecting the ground terminals on all Units and the functional ground, and grounding the line at one location to 100 Ω or less, connect the shield only at one end of each line, as shown in *Figure A*.

If the Removable Box's functional ground terminal is not grounded, connect the shield at both ends of each line, as shown in *Figure B*.

If a CJ1W-CIF11 is also connected in the system, connect the lines and shield as shown in *Figure B*.

Figure A

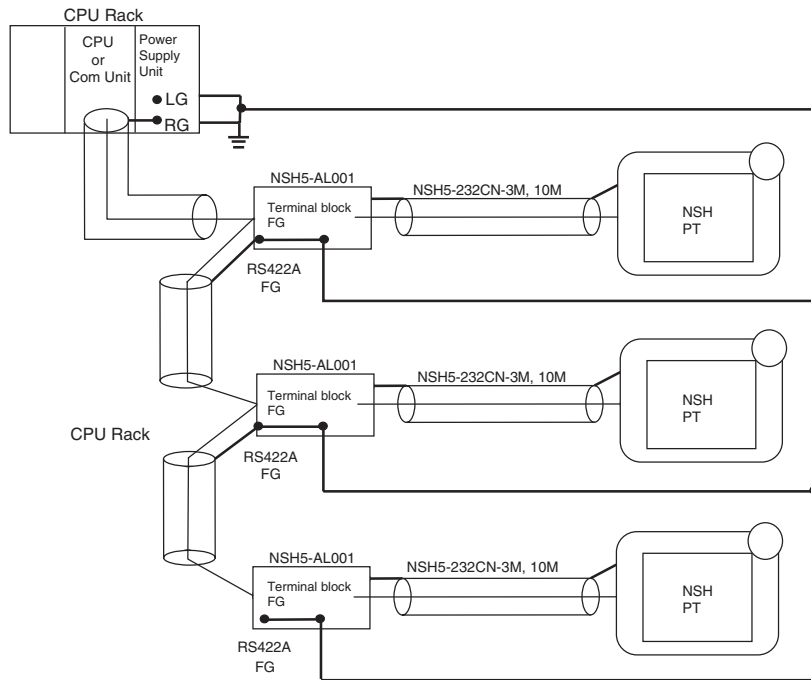
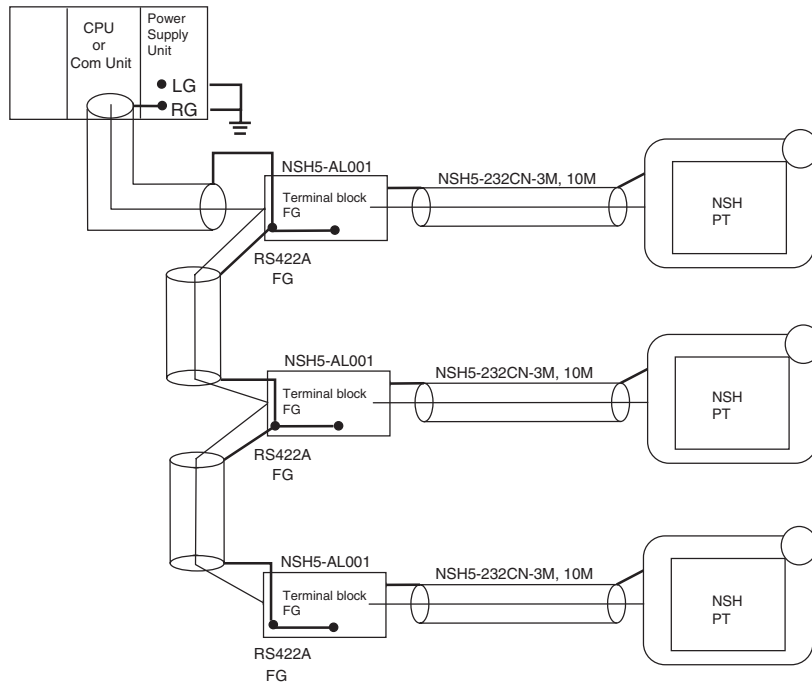
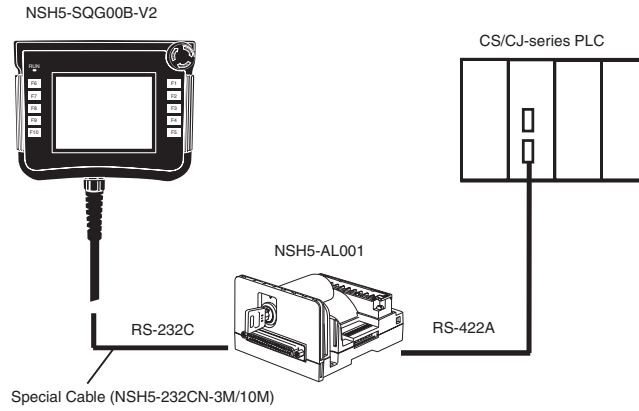

Figure B



Connection Formats

• Connection via a NSH5-AL001 Removable Box



• 1:N Connections via NSH5-AL001 Removable Box

The total communications distance can be up to a 500 m.

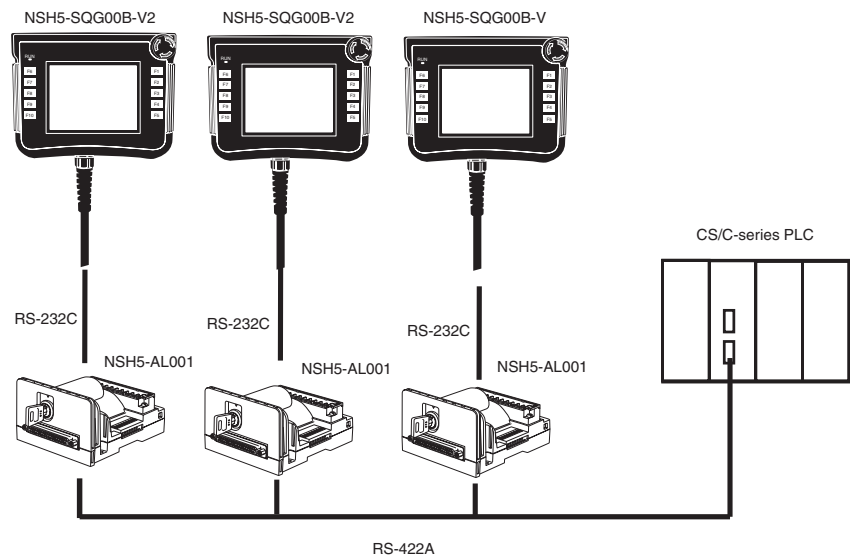

• 1:N Connections Including a Conversion Unit Other Than the NSH5-AL001

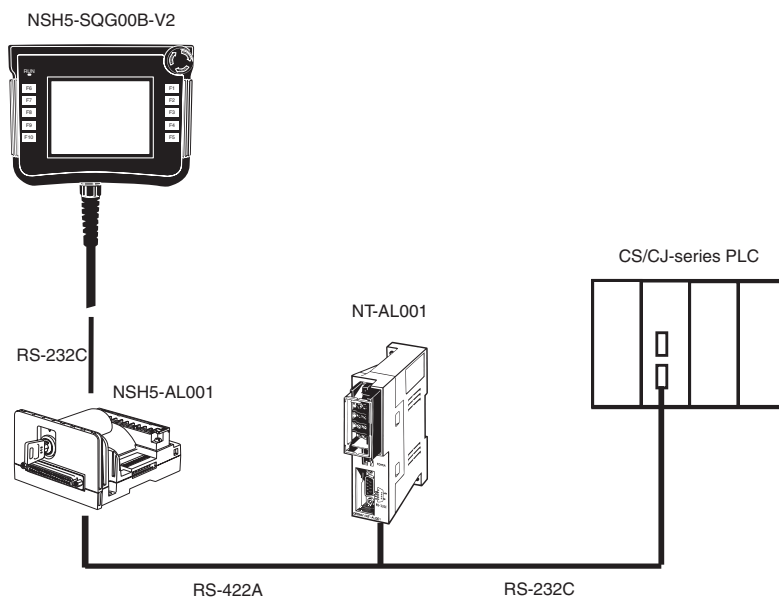

- Note**
- (1) When the CJ1W-CIF11 is included in the connections, the maximum communications distance is 50 m. When the CJ1W-CIF11 is not included in the connections, the maximum communications distance is 500 m.
  - (2) If ground potential differences or noise is a concern, the insulated NT-AL001 RS-232C/422A Conversion Unit is recommended for all connections.

# SECTION 5

## Inspection and Maintenance

This section describes inspection and maintenance and the contents of error messages for the NSH5 Programmable Terminal.

5-1	Maintenance .....	66
5-2	Inspection and Cleaning .....	67
5-3	Error Message Tables .....	69
5-4	Precautions When Replacing the PT.....	69

## 5-1 Maintenance

Perform maintenance operations to keep the NSH5-series PT in optimum condition.

 **WARNING** Do not disassemble the PT or touch the inside of the PT while the power is turned ON. Doing so may result in electrical shock.

**Backing Up Project Data** Be sure to back up project data and store it in a secure location, in case the PT should have to be sent out for repairs or be replaced.

**Keeping a Spare PT** It is recommended that a spare PT be kept on hand, in order to enable faster system recovery in case the original PT should be damaged or the screen cannot be read due to reaching the end of the backlight service.

**Replacing the Backlight** If the brightness of the backlight is diminished and the screen becomes difficult to read, the backlight must be replaced. A backlight cannot be replaced by the user. If this situation occurs, please contact an OMRON representative. Ordinarily a backlight would need to be replaced after approximately 75,000 hours at normal temperature and humidity. The service life is shortened in an extremely cold environment. Replace the backlight if the brightness diminishes and the screen becomes difficult to read.

**Replacing the Battery** Screen data such as calendars, clocks, and log data are backed up by a lithium battery. The battery service life is approximately five years when used in an environment with a temperature of 25°C. If the temperature at the location of use is higher than this, the battery life will be shortened. Change the battery at suitable intervals in accordance with the operating environment. It is recommended that a spare battery be kept on hand so that the battery can be quickly replaced when necessary.

### Replacement Battery

The replacement battery shown below is a lithium battery for backing up the memory contents.

Model	Specifications
CJ1W-BAT01	Replacement battery for the NSH5

### Replacement Criteria

Replace the battery under the following conditions.

- When five years have elapsed since a new battery was last installed
- Within five days of when the RUN indicator turns orange

**Note**

- (1) Never use a battery that has been subjected to any strong impact, such as being dropped on the floor, as the battery may lead fluid.
- (2) Before installing a battery, check the battery type and be sure to install it correctly.

**Replacement Procedure**

Use the following procedure to replace the battery.

- 1,2,3...**
1. Remove the back cover from the PT. The battery is located as shown in the diagram below. (For details on removing the back cover, refer to 2-3 *Connecting the Special Cable.*)

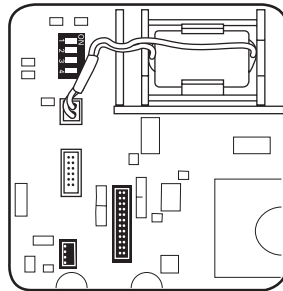

2. To replace the battery, remove the connector as shown below.

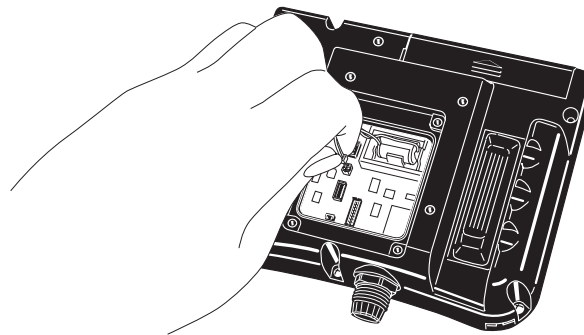

**Note** Replace the battery within five minutes of disconnecting it.

## 5-2 Inspection and Cleaning

Clean and inspect the NSH5-series PT regularly to ensure that it is always used under optimum conditions.

**Cleaning**

If the display gets dirty, the screen becomes difficult to read. Clean the screen periodically as follows:

- Wipe the display daily with a dry, soft cloth. If the soil is particularly heavy, attempting to remove it by wiping with a dry cloth may damage the front sheet of the PT. In that case, wipe it with a damp cloth.
- If the soiling cannot be wiped off with a dry cloth, wet the cloth with diluted neutral detergent (2%) and wring it out well before using it.
- If rubber or vinyl products, tape, etc., are left stuck to the display for long periods, they will cause staining. If such items are stuck to the display, remove them during cleaning.

**Note** Never use chemical dusters or volatile solvents such as benzenes or thinners.

**Inspection Interval**

In normal environments, inspect the PT at intervals of six months to one year. If the PT is used in an environment that is extremely hot and humid, or very dusty, shorten the inspection interval.



**Items to Inspect**

Inspect the following items to determine whether there is any divergence from the stated criteria. If there is, either improve the surrounding environment so that the values fall within the stated range, or adjust the PT by, for example, re-tightening screws.

Inspected item	Inspection details	Criteria	Method
Power supply voltage	Fluctuation in power supply terminal voltage	Allowable voltage fluctuation range (24 VDC $\pm$ 15%)	Tester
Ambient environmental conditions	Ambient temperature	0 to 40°C	Thermometer
	Ambient humidity	35% to 85%	Hygrometer
	Presence of dust	There must be no accumulated dust.	Visual
	Presence of oil	There must be no oil penetrating between the front-panel sheet and the plastic.	Visual
Mounting conditions	Looseness of mounting brackets	Must be tightened to the specified torque.	Phillips screwdriver
	Connecting cable connections	Must be fully inserted and locked, with no looseness.	Visual
	Looseness of screws in external wiring	There must be no looseness.	Phillips screwdriver
	Conditions of external connecting cables	Must not be starting to break or have other faults.	Visual, tester
Consumable parts	Brightness of backlight	Must be sufficiently bright. Backlight service life: 50,000 hours at 25°C	Visual
	Battery	5 years (at 25°C)	Replacement every five years

**Note**

- (1) Do not disassemble for repairs or modification.
- (2) Disposal of batteries may be regulated by local authorities. Dispose of them in accordance with the applicable laws and regulations.

## 5-3 Error Message Tables

### When a Project Is Newly Created

Error message	Contents	Countermeasure
The combination of the selected PT model and system version is invalid.	An attempt was made to select a version not supported by NSH5-SQ□-V2.	Select a version to match the PT.

### During System Setup

Error message	Contents	Countermeasure
There is an error in the communications address input format.	An illegal address or other than a bit address has been set for the key status monitor address (emergency stop, function switches F3, F4, F5, F8, F9, F10).	Check the key status monitor address and correct the address that was set.
	An illegal address or other than a word address has been set for the station status monitor address.	Check the station status monitor address and correct the address that was set.
\$SB cannot be specified.	\$SB was specified for the station status monitor address.	Set an address other than \$SB.
\$SW cannot be specified.	\$SW was specified for the station status monitor address.	Set an address other than \$SW.
Specify a PT memory address.	An address not in the PT memory was specified for the station status monitor address.	Check the station status monitor address and set an address in the PT memory.
The combination of the selected PT model and system version is invalid.	An attempt was made to convert a project that is being edited to a PT model that is not supported.	Select a version that matches the PT model.

## 5-4 Precautions When Replacing the PT

If a fault is discovered in the inspection and the PT must be replaced, observe the following precautions.

- Before replacing the PT, back up all of the PT's project data. If the PT is repaired by OMRON, the project data may be deleted.
- Before replacing the PT, be sure to turn OFF the power supply.
- After replacing the PT, check to be sure that there are no errors in the new PT.

If the PT is to be returned to OMRON for repair, attach a document to the PT describing the problem in as much detail as possible, and send the PT to an OMRON representative listed at the end of the manual.



# Appendix A

## General Specifications

### General Specifications

Item	Specifications
Rated power supply voltage	24 VDC
Allowable power supply voltage range	20.4 to 27.6 VDC (24 VDC $\pm$ 15%)
Power consumption	10 W max.
Ambient operating temperature (See note 1.)	0 to 40°C
Ambient storage temperature (See note 1.)	-20 to 60°C
Ambient operating humidity	35% to 85% max. (with no condensation)
Ambient operating environment	No corrosive gases
Noise resistance	Conforming to IEC 61000-4-4: 2 kV (power supply line)
Vibration resistance (during operation)	10 to 57 Hz with double amplitude of 0.075 mm, 57 to 150 Hz with acceleration of 9.8 m/s <sup>2</sup> thirty minutes each in X, Y, and Z directions
Shock resistance (during operation)	147 m/s <sup>2</sup> three times each in X, Y, and Z directions
Drop test (See note 2.)	Dropped from 1 m. Conforming to JIS B 3502/IEC61131-2.
External dimensions	223 × 179 × 70.5 mm (W × L × H)
Weight	1.1 kg max.
Enclosure rating (See note 3.)	IP65
Ground	100 $\Omega$ or less
Battery life	Battery life: 5 years (25°C) Low battery: Replace within five days of the indicator turning orange. SRAM, RTC backup possible. The SRAM and RTC can be backed up by a super capacitor for five minutes after the old battery is removed (after the power has been turned ON for five minutes).
Applicable standards	EC Directives and UL508

**Note** (1) Use the PT within the ambient operating and storage temperature ranges shown below.

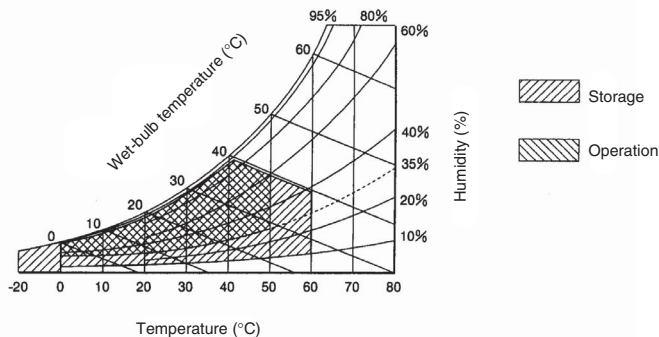

- (2) Conformance is evaluated under applicable test conditions, and it may not be possible to use the PT in every environment.
- (3) Conformance is evaluated under applicable test conditions, and it may not be possible to use the PT in every environment. When used over a long period of time, the drip-proof packing may become damaged or dirty and lose its effectiveness.

## Display Specifications

Item		Specifications
Display panel	Display device	Color STN LCD (with backlight)
	Number of dots	320 horizontal × 240 vertical dots
	Display colors	256 colors (4,096 colors for BMP/JPG images)
	Effective display area	115.18 horizontal mm × 86.38 mm vertical (5.7 inches)
	View angle	Left/right ±50°; down 50°; up 45°
	Contrast adjustment	100 levels
Backlight (See note 4.)	Service life	75,000 hours min. (See note 1.)
	User replacement	Not possible.
	Brightness adjustment	There are three levels of adjustment by operating the touch panel. (See note 2.)
	Automatic backlight-OFF function	Screen-saver function: 1 to 255 min, in units of 1 min, turned ON/OFF by system memory operation.
	Backlight error detection	Error is detected automatically at startup, and the RUN indicator flashes green as notification. (See note 3.)
Front-panel indicator	RUN	<p>Lit green: PT is operating normally.</p> <p>Flashing green: The Memory Card transfer has ended normally or a backlight error was detected immediately after the power was turned ON.</p> <p>Lit orange: Immediately after power is turned ON, indicates file system check in progress, battery low, or disconnected and operating normally.</p> <p>Flashing orange: Memory Card transfer in progress.</p> <p>Lit red: Memory Card transfer has ended abnormally.</p>

- Note**
- (1) This is the estimated time until brightness is reduced by half at room temperature and humidity. It is only a reference value. The service life will be drastically shortened if the PT is used at low temperatures. For example, using the PT at 0°C will reduce the service life to approximately 10,000 hours (reference value).
  - (2) The brightness cannot be greatly adjusted.
  - (3) This function does not detect the end of service life. It detects when the backlight is not lit due to a disconnection or other error. Backlight error detection indicates that all backlights are OFF.
  - (4) Contact your nearest OMRON representative to replace the backlight.
  - (5) There may be some defective pixels in the display. This is not a fault as long as the numbers of defective light and dark pixels fall within the following standard range.

Model	Standard range
NSH5-SQR00B-V2 NSH5-SQG00B-V2	Number of light and dark pixels: 4 or fewer defects the size of $0.2 < (\text{minor axis} + \text{major axis}) \leq 0.55$ mm (within 1 per 20 mm)

## Operating Area Specifications

Item		Specifications
Touch panel (matrix type)	Method	Resistive membrane
	Number of switches	300 (20 horizontal × 15 vertical), 1 switch: 16 × 16 dots
	Inputs	Pressure-sensitive
	Service life	1,000,000 touch operations, min.
Enabling switch	Mechanical durability	OFF to ON: 1,000,000 min. OFF to ON to OFF (direct circuit breaking): 100,000 min.
	Electrical durability	100,000 min.
Emergency stop switch	Mechanical durability	100,000 min.
	Electrical durability	100,000 min.

## User Memory Specifications

Item	Specifications
Standard screen data capacity	20 MB (No expansion structure)

## USB Interface Specifications

Item		Specifications
Slave	Applicable standards	USB version 1
	Baud rate	Full speed: 12 Mbps Low speed: 1.2 Mbps
	Number of ports	1 port
	Support transfer modes	Controlled transfer, batch transfer, interrupt transfer
	Power consumption	1 mA (for host connection detection circuit)

## External Output Interface Specifications

Item	Specifications
Function switches	SPST-NO Rated voltage: 24 V Max. rated current: 50 mA
Emergency stop switch	DPST-NC contact + NO bit Rated voltage: 24 V Max. rated current: 100 mA Min. applicable load: 1 mA at 5 VDC
Enabling switch	DPST-NO Rated voltage: 24 V Max. rated current: 100 mA Min. applicable load: 4 mA at 24 VDC

## DIP Switch Settings

Pin No.	Description	ON	OFF
SW1	Built-in terminating resistance setting	Terminating resistance is connected.	Terminating resistance is not connected.
SW2	---		Always OFF
SW3	---		Always OFF
SW4	---		Always OFF

## Removable Box Specifications

Item	Specifications
Rated power supply voltage	24 VDC
Allowable power supply voltage range	20.4 to 27.6 VDC(24 VDC $\pm$ 15%)
Power consumption	10 W max.
Ambient operating temperature	0 to 55°C
Ambient storage temperature	-20 to 70°C
Ambient operating humidity	10% to 90% (with no condensation)
Ambient operating environment	No corrosive gases
Noise resistance	Conforms to IEC 61000-4-4: 2 kV (power supply line).
Vibration resistance (during operation)	5 to 9.1 Hz with 4.5-mm single amplitude, 9.1 to 150 Hz with acceleration of 14.7 m/s <sup>2</sup> for 60 minutes each in X, Y, and Z directions
Insulation resistance	20 M $\Omega$ between all RS-422A signals and functional ground
Dielectric strength	720 VDC for 1 min between all RS-422A signals and functional ground, leakage current: 5 mA max.
Shock resistance (during operation)	147 m/s <sup>2</sup> three times each in X, Y, and Z directions
Weight	300 g max.
Degree of protection	None (See note.)
Ground	100 $\Omega$ or less
Applicable standards	EC Directives, no UL certification

**Note** Do not use the Removable Box in environments that require water resistance or oil resistance.

## Terminal Block Specifications

Item	Specifications
Rated voltage	250 VAC
Rated current	10 A (Use wires that are 1.25 mm <sup>2</sup> or larger.)
No. of terminals	22

## RS-232C Specifications

Item	Specifications
Communications standard	EIA RS-232C
Communications distance	10 m max.
Connector	37-pin D-sub connector

## RS-422A Specifications

Item	Specifications
Communications standard	EIA RS-422A
Communications distance	500 m max.
Connector	8-pin





# Appendix B

## Dimensions

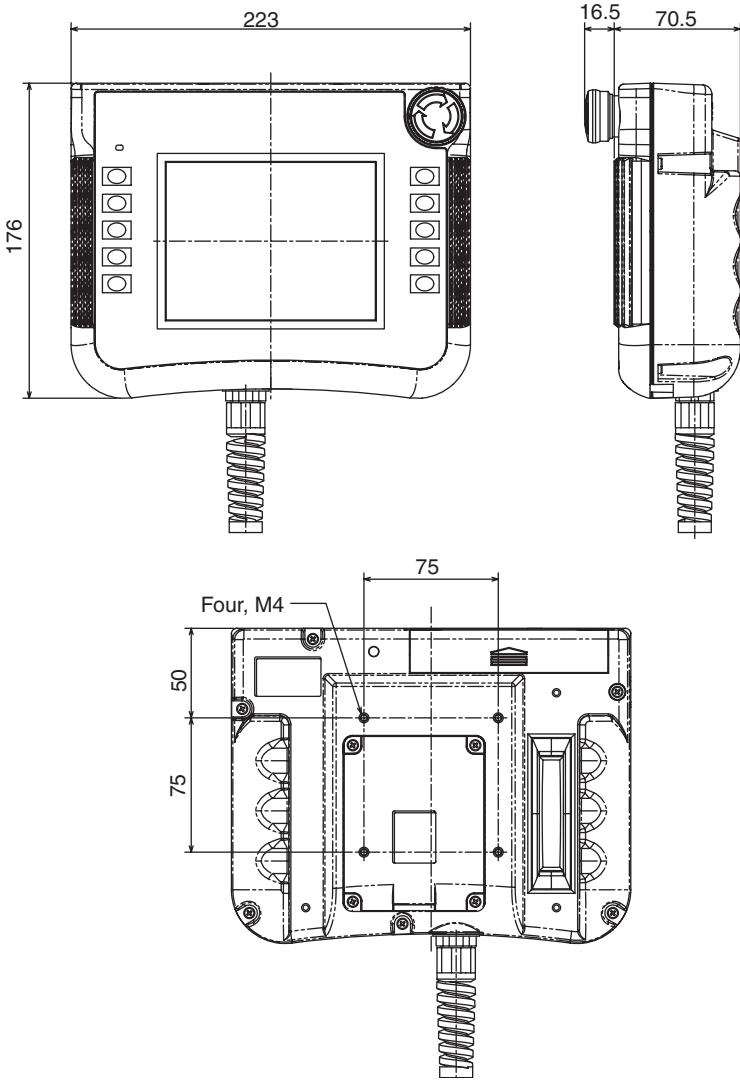

Mounting Bracket Dimensions (Unit: mm)

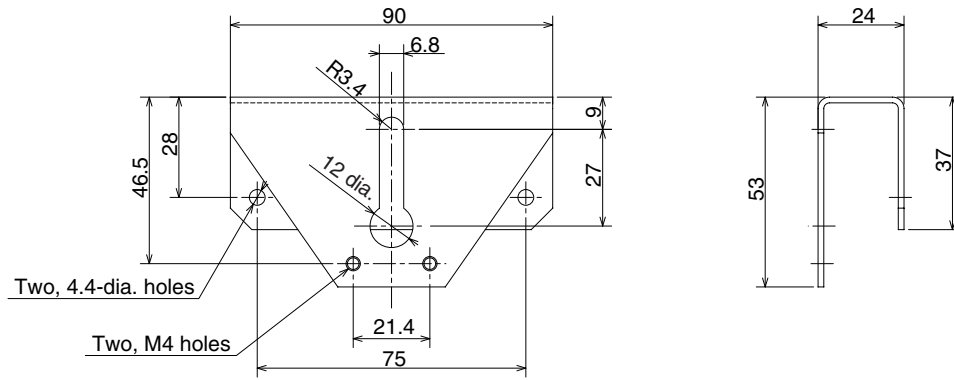

Visor Dimensions

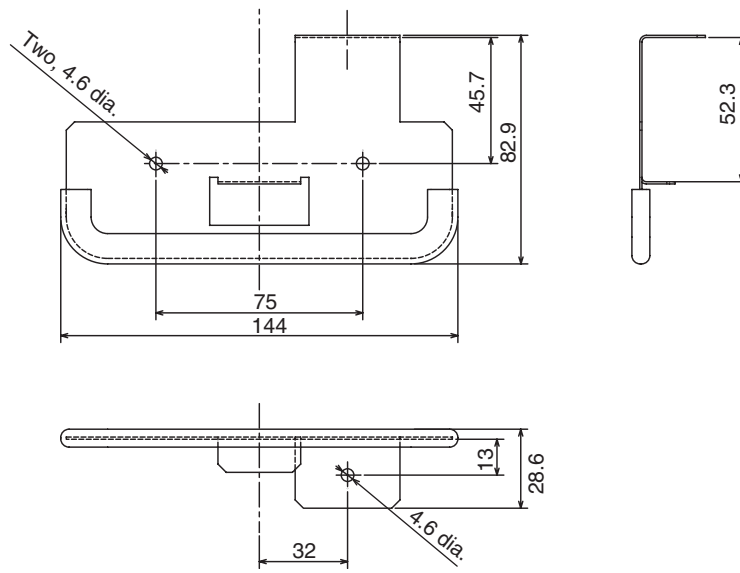

# Appendix C

## Types of Memory

### Function Switch and Emergency Stop Switch Notification Destinations

#### PT Memory

Symbol	PT Memory	Allocation
\$B	Internal bit memory	Yes
\$W	Internal word memory	---
\$HB	Internal holding bit memory	Yes
\$HW	Internal holding word memory	---
\$SB	System bit memory	---
\$SW	System word memory	---

#### Host (PLC) Memory

Symbol	C-series PLC	Allocation	CVM1/CV-series PLC	Allocation	CS-CJ-series PLC	Allocation
None	IR Area	Yes	CIO Area	Yes	CIO Area	Yes
H	Holding Area	Yes	---	---	Holding Area	Yes
A	Auxiliary Area	Yes	Auxiliary Area	No	Auxiliary Area	Yes
L	Link Area	Yes	---	---	Link Area	Yes
T	Timer PV	No	Timer PV	No	Timer PV	No
TU	---	---	---	---	Timer Completion Flag	No
C	Counter PV	No	Counter PV	No	Counter PV	No
CU	---	---	---	---	Counter Completion Flag	No
W	---	---	---	---	Work Area	Yes
TK	---	---	---	---	Task Flag	No
D	DM Area	No	DM Area	No	DM Area	Yes
E	EM Area	---	EM Area	No	EM Area	Yes
E0_	---	---	---	---	EM Bank	Yes
EC_	---	---	---	---	EM Bank	Yes

### Station Status Monitor Address Allocation Destinations

#### PT Memory

Symbol	PT Memory	Allocation
\$W	Internal word memory	Yes
\$HW	Internal holding word memory	Yes
\$SW	System word memory	---



# Appendix D

## Comparison of Functions with NS-Designer

The following tables show the CX-Designer menus, commands, and functions that correspond to NS-Designer menus.

Menu	CX-Designer menu/function	NS-Designer menu command
File	File - New Project	New Project
	File - Open Project	Open Project
	File - Save Project	Save Project
	File - Save Project As	Save Project As
	---	Template
	---	Project Maintenance
	File - New Screen	New Screen
	File - Open Screen	Open Screen
	---	Close Screen
	File - Save Screen/Sheet	Save Screen
	File - Save All	Save All
	Project Workspace - Screen/Sheet Tab Page	Open Sheet
	File - Apply Sheet	Apply Sheet
	File - Import CSV File	Import CSV File
	File - Export CSV File	Export CSV File
	PT - Transfer	Transfer Data
	File - Print	Print
	File - Recent Projects	Recent Projects
	File - Exit	Exit
Edit	Edit - Undo	Undo
	Edit - Redo	Redo
	Edit - Cut	Cut
	Edit - Copy	Copy
	Edit - Paste	Paste
	Edit - Repeat	Offset Paste
	Edit - Delete	Delete
	Edit - Find	Find
	Edit - Replace	Replace
	Edit - Select All	Select All
	Edit - Repeat	Repeat

Menu	CX-Designer menu/function	NS-Designer menu command
View	View - Toolbar	Toolbar
	View - Status Bar	Status Bar
	View - Previous Label	Switch Label
	View - Next Label	
	View - Previous Screen	Previous Screen
	View - Next Screen	Next Screen
	View - Previous Frame Page	Previous Frame Page
	View - Next Frame Page	Next Frame Page
	View - Simulate ON/OFF	Simulate ON/OFF
	View - Show ID	Show ID
	View - Show Address - Show Address	Show Address
	Output Window - Data Check Results Tab Page	Show Error Object
	View - Show Sheet Object	Show Sheet Object
	View - Show Touch Points	Show Touch Points
	View - Zoom	Zoom
	View - Refresh	Refresh
Functional Object	Functional Object - ON/OFF Button	ON/OFF Button
	Functional Object - Word Button	Word Button
	Functional Object - Command Button	Command Button
	Functional Object - Bit Lamp	Bit Lamp
	Functional Object - Word Lamp	Word Lamp
	Functional Object - Label	Label
	Functional Object - Numeral Display & Input	Numeral Display & Input
	Functional Object - String Display & Input	String Display & Input
	Functional Object - List Selection	List Selection
	Functional Object - Thumbwheel Switch	Thumbwheel Switch
	Functional Object - Analog Meter	Analog Meter
	Functional Object - Level Meter	Level Meter
	Functional Object - Broken-line Graph	Broken-line Graph
	Functional Object - Bitmap	Bitmap
	Functional Object - Alarm/Event Display	Alarm/Event Display
	Functional Object - Alarm/Event Summary & History	Alarm/Event Summary & History
	Functional Object - Date	Date
	Functional Object - Time	Time
	Functional Object - Data Log Graph	Data Log Graph
	Functional Object - Data Log Table	Data Log Table
Functional Object - Video Display	Video Display	
Functional Object - Frame	Frame	
Functional Object - Table	Table	
Functional Object - Temporary Input	Temporary Input	
Fixed Object	Fixed Object - Rectangle	Rectangle
	Fixed Object - Circle/Oval	Circle/Oval
	Fixed Object - Straight Line	Straight Line
	Fixed Object - Polyline	Polyline
	Fixed Object - Polygon	Polygon
	Fixed Object - Sector	Sector
	Fixed Object - Arc	Arc

Menu	CX-Designer menu/function	NS-Designer menu command
Settings	PT - Object Properties	Object Properties
	PT - Edit Label	Edit Label
	Edit - Edit Properties	Change Settings at Once
	PT - Flicker	Flicker
	PT - Password	Password
	PT - Unit/Scale	Unit/Scale Setting
	PT - Alarm/Event Setting	Alarm/Event Setting
	PT - Data Log Setting	Data Log Setting
	PT - Data Block Setting	Data Block Setting
	PT - Change Input Order	Change Input Order
	PT - Project Properties	Project Properties
	PT - Screen/Sheet Properties	Screen Properties
	PT - System Setting	System Setting
	PT - Communication Setting	
	Tool - Reset Defined Default	Reset Defined Default
	Tool - Convert	Convert
	PT - Communication Setting	Register Hosts
Layout	Edit - Align/Distribute	Align/Distribute
	Edit - Make Same Size	Make Same Size
	Edit - Order	Order
	Edit - Nudge	Nudge
	Edit - Rotate/Flip	Rotate/Flip
	Edit - Edit Node	Modify
	Edit - Group - Group	Group
	Edit - Group - Ungroup	Ungroup
	View - Grid	Grid
Tool	Project Workspace - Screen/Sheet Tab Page	Screen Maintenance
	Project Workspace - Screen/Sheet Tab Page	Sheet Maintenance
	Tool - Validation	Error Check
	Output Window - Data Check Results Tab Page	Validation Result
	Edit - Edit Properties	Functional Object List
	View - Window - Select Object	List Up Functional Objects Used
	View - Window - Address in Use List	List Up Addresses Used
	Find - Address Cross Reference	Address Cross Reference
	---	Edit Background Bitmap
	Tool - Library	Register Library
	Tool - Library	Use Library
	Tool - Test	Test
	Tool - Resource Report	Resource Report
	Tool - Options	Option
Window	Window - Cascade	Cascade
	Window - Tile	Tile
	Window - Arrange Icons	Arrange Icons
Help	Help - Contents	Contents
	Help - Search Topic	Search Topic
	Help - About CX-Designer	About NS-Designer





# Appendix E

## Recommended Enabling Circuits

### Example: Using the Enabling Switch in an Assembly Robot Line

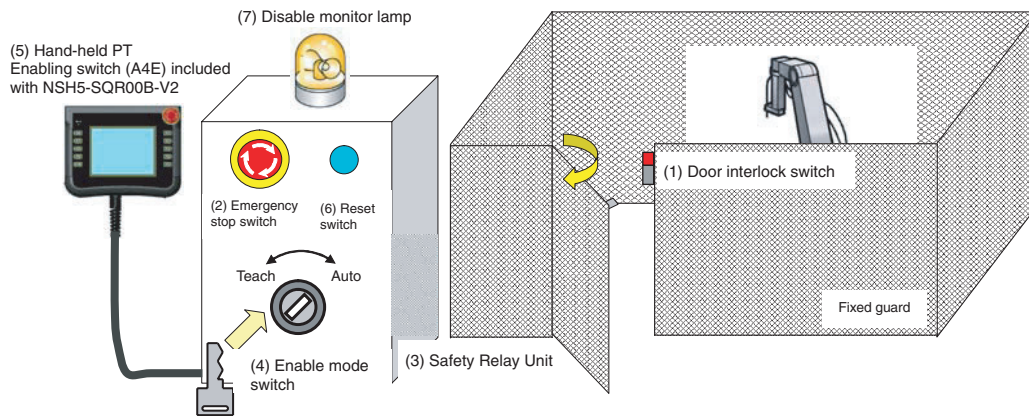

To ensure safe operation in an assembly robot line, be sure to establish an overall equipment safety policy in line with the ISO 13849 safety category.

Assuring safe operation involves installing various safety equipment, and robots must be taught at the time that production lines are set up. Humans must also sometimes perform tasks in hazardous areas. The procedure below describes how to use the enabling switch when bringing a device such as the NSH5 close to a robot to perform operations.

1. Hold the NSH5 (5 in the diagram) enabling switch in the middle position.
2. Turn the enable mode switch (4) from normal mode to enable mode. While teaching, the door interlock switch (1) is disabled and the disable monitor lamp (7) lights.  
The reasons for installing the switch are as follows:
  - It restricts the personnel doing the teaching to those who have a key.
  - It makes personnel conscious of teaching and entering a hazardous area.
  - Operations from outside are disabled while teaching is in progress.
  - The door interlock switch signal (1) can be controlled by the enabling switch.
  - The disable monitor lamp is lit to let other personnel in the area know that teaching is in progress.
3. Carry the NSH5 into the hazardous area and perform the operation.
4. If either the enabling switch or the emergency stop switch is actuated during operation, use the reset switch (6) to manually reset the equipment.
5. The emergency stop switch (2) is always enabled.

### **Block Diagram When a Relay Unit Is Used**

1. In normal mode, safety line 1 is enabled, and the door interlock switch (1) is enabled by the Safety Relay Unit.
2. Enable Safety Relay Unit 2 by holding the NSH5's enabling switch in the middle position.
3. Turn the enable mode switch (4) from normal mode to enable mode, and switch from safety line 1 to safety line 2.
4. Always keep the emergency stop switch (2) ready to operate.
5. If either the enabling switch or the emergency stop switch is actuated during operation, use the reset switch (6) to manually reset the equipment.

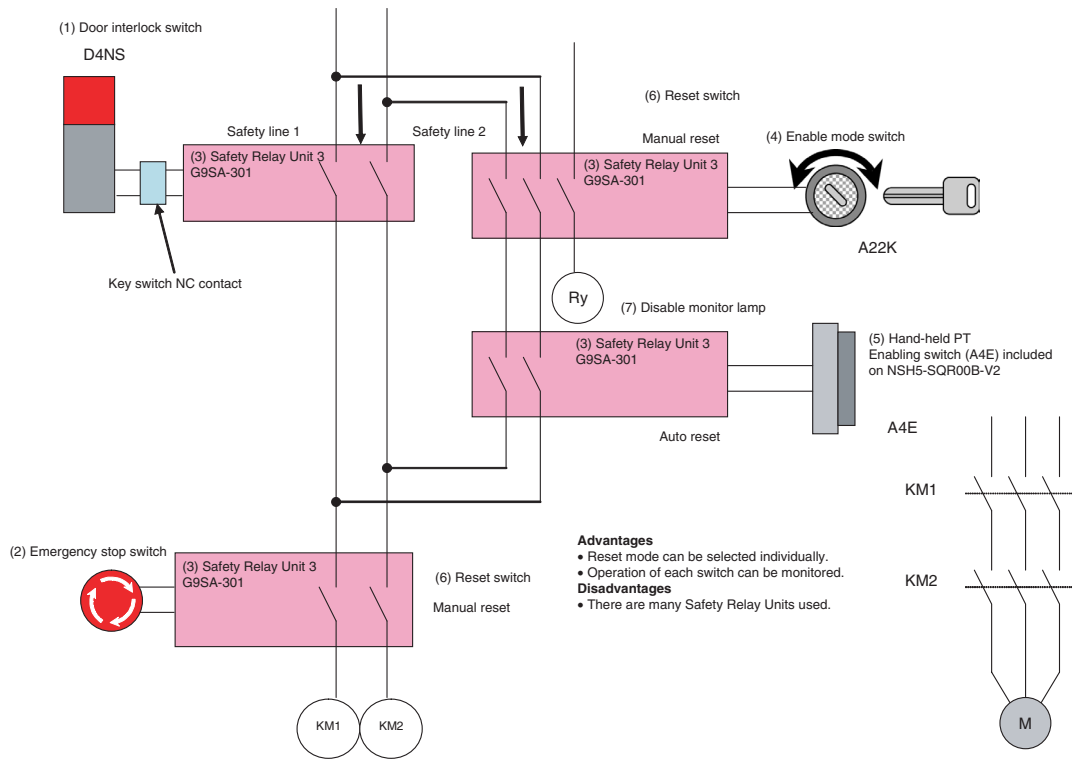

### Circuit Diagram

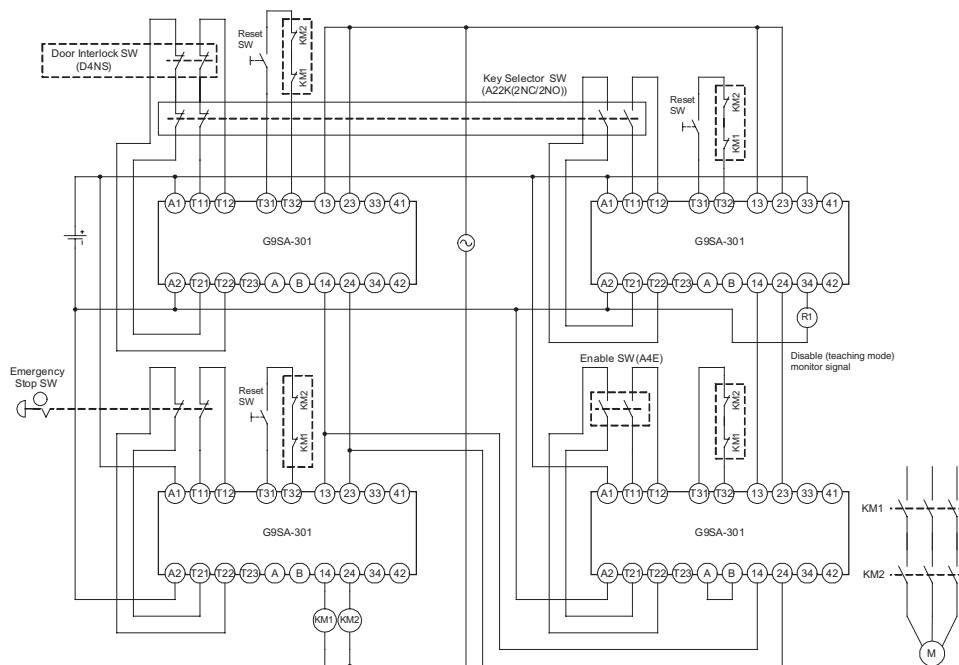

### Block Diagram When an SNC Unit Is Used

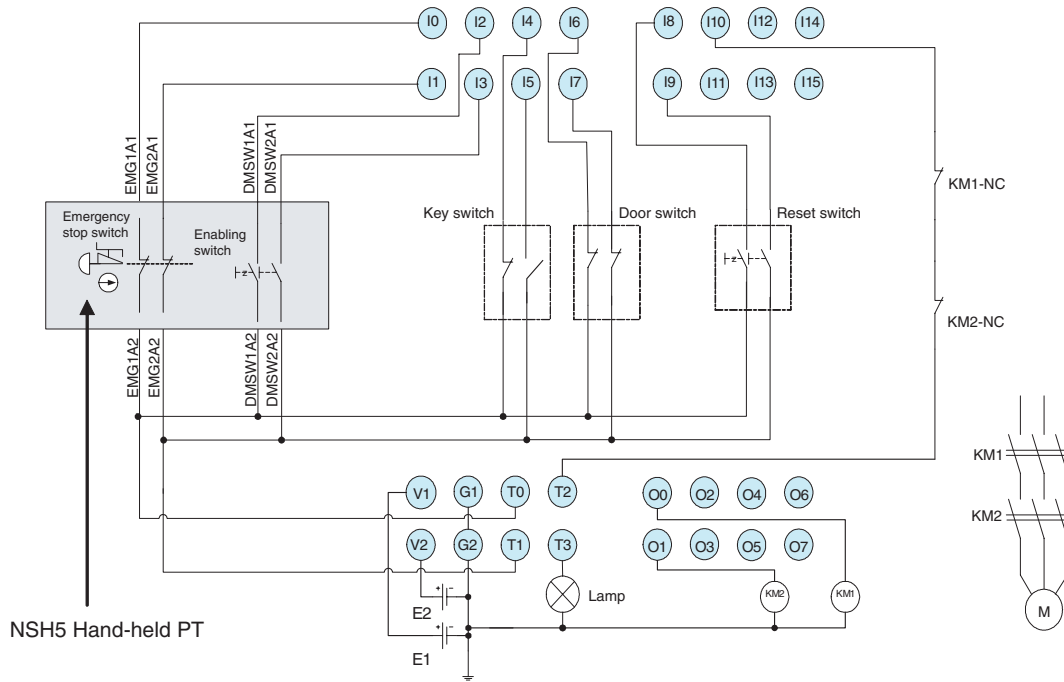

E1, E2: 24-VDC power supply

S1, S2: Reset switch

KM1, KM2: Contactor

V1/G1, V2/G2, I0 to I15, O0 to O7, T0 to T1: NE1A terminals. Connect a 24-VDC power supply to the V0/G0 power supply terminals for the NE1A internal circuit.

## Local Inputs, Test Outputs,

Terminal name	Mode	Test source	Terminal tag name	Application
IN0	Test Pulse from Test Output	T0	E-Stop 2NC-1	Emergency stop switch
IN1	Test Pulse from Test Output	T1	E-Stop 2NC-2	
IN2	Test Pulse from Test Output	T0	Enable Switch 2NO-1	Enabling switch
IN3	Test Pulse from Test Output	T1	Enable Switch 2NO-2	
IN4	Test Pulse from Test Output	T0	Key Switch NC	Key switch for changing modes
IN5	Test Pulse from Test Output	T1	Key Switch NO	
IN6	Test Pulse from Test Output	T0	Door Switch 2NC-1	Door switch
IN7	Test Pulse from Test Output	T1	Door Switch 2NC-2	
IN8	Test Pulse from Test Output	T0	Reset Switch 2NO-1	Reset switch
IN9	Test Pulse from Test Output	T1	Reset Switch 2NO-2	
IN10	Test Pulse from Test Output	T2	EDM Feedback	Feedback for KM1, 2
T0	Test Pulse	---	---	---
T1	Test Pulse	---	---	---
T2	Test Pulse	---	---	---
T3	Standard Output	---	Mode Indicator	Mode indicator
Out0	Safety Pulse Test	---	KM1	Safety output
Out1	Safety Pulse Test	---	KM2	Safety output

## Operation Chart

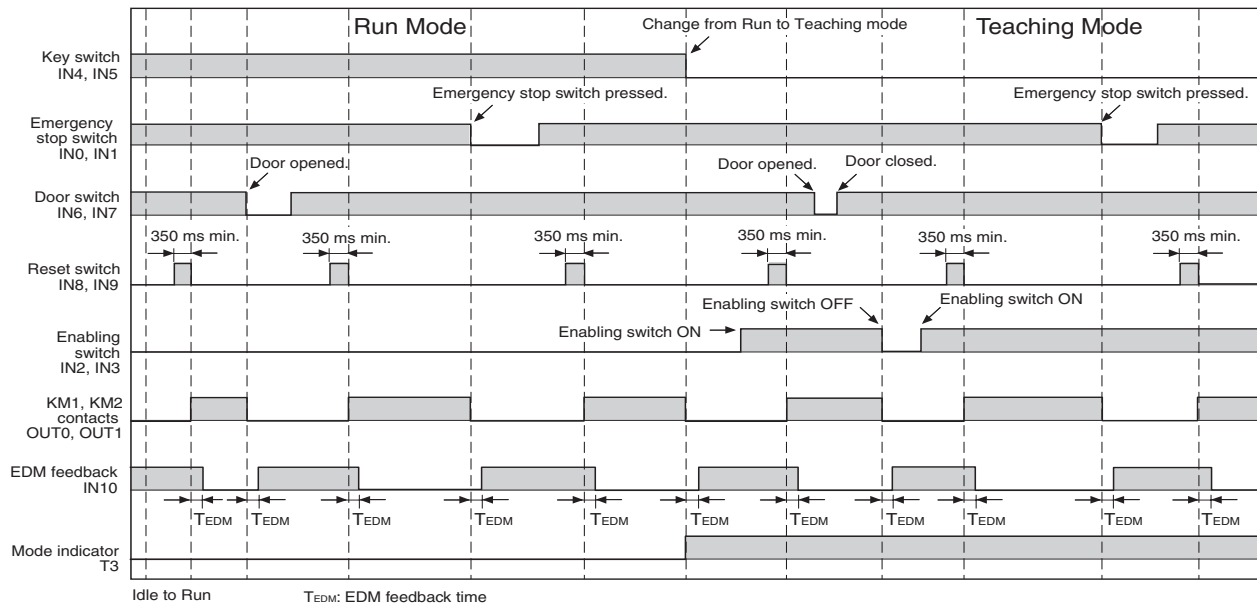

# Program Example

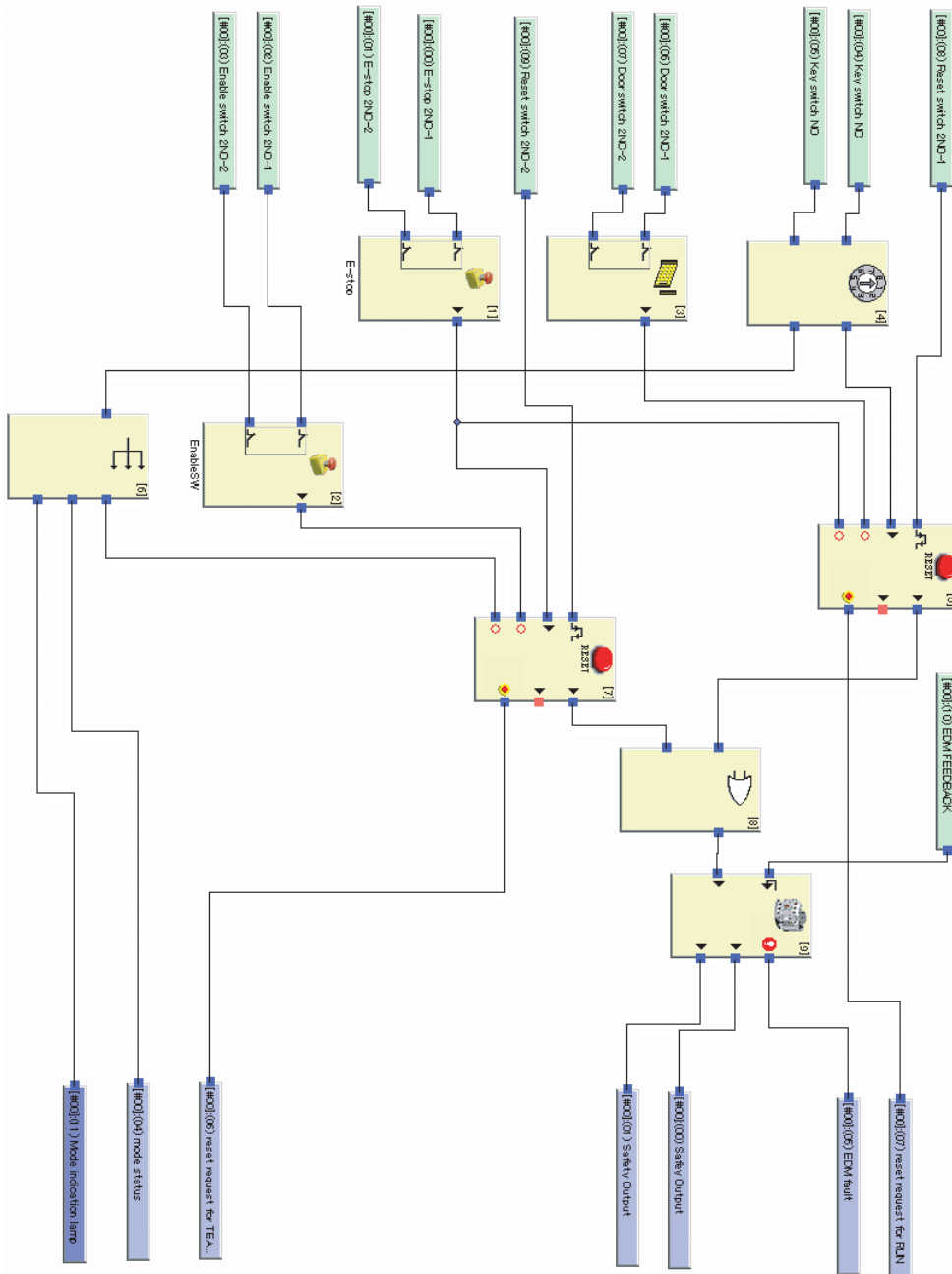



# Appendix F

## Removable Box Application Examples

Installing NSH5-AL001 Removable Boxes enables using the station status monitor address function to create an application like the one described in this section.

In this section, actual examples are given for creating applications, including the required CX-Designer settings. The communications address and set values used in the following descriptions are only examples. The user must adjust these examples to suit their own actual application conditions.

1. The screen that is displayed will change depending on the station number of the Removable Box connected to the NSH5.
2. The PLC is notified of the station number of the Removable Box attached to the NSH5. (The method for clearing the station number sent to the PLC when the NSH5 is not connected is also described.)

### Connecting a Single NSH5 PT

The following description is for connecting a single NSH5. Use the following steps to set up the system.

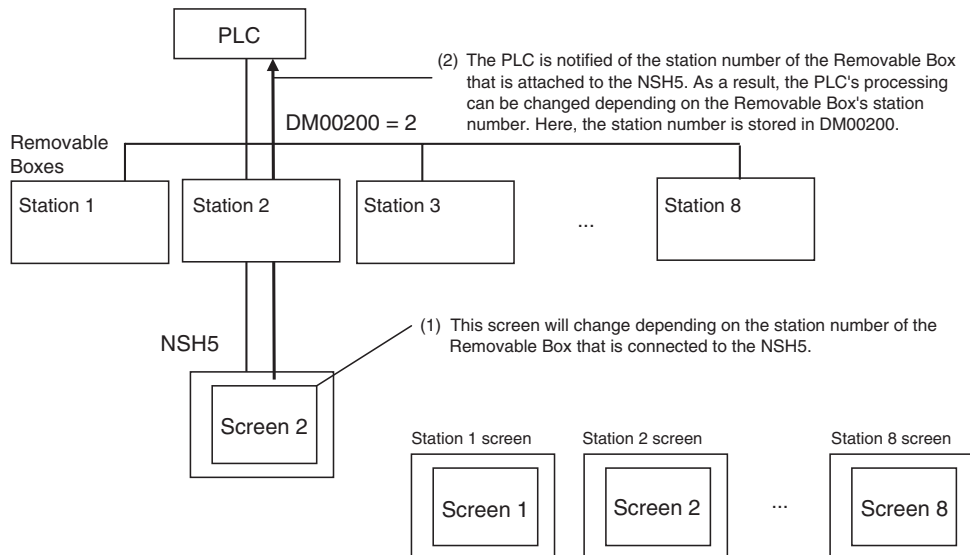

1. **Removable Box Setting**  
The station number for the Removable Box is set using the rotary switch. For setting details, refer to 4-2 *Nomenclature and Functions* and Functions and 4-3 *Switch Settings*.
2. **Station Status Monitor Address Settings**  
Use the following procedure to enter settings in the CX-Designer.
  - (1) Select **System Setting** from the CX-Designer's PT Menu.
  - (2) Click the **NS Handy Terminal** Tab in the System Setting Dialog Box.
  - (3) Enter  $\$W1000$  in the Station Status Monitor Address Field



(4) Click the **OK** Button to close the System Setting Dialog Box.

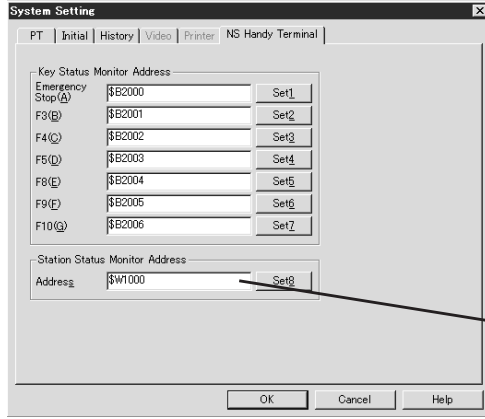

(3) Enter \$W1000 for the Station Status Monitor Address.

3. Creating a Screen for Each Station

Create screens for stations so that the station numbers and the screen numbers match.

Screen number	Application
0	Initial screen (Displayed when NSH5 is started.)
1	Screen for Station 1
2	Screen for Station 2
---	---
8	Screen for Station 8

4. Macro Settings

Use the following steps to change the screen and notify the PLC of the NSH5's station number based on changes to the Station Status Monitor Address.

- (1) Select **Project Properties** from CX-Designer's PT Menu.
- (2) Click the **Macro** Tab in the Project Property Dialog Box.
- (3) Click the **Set** Button for the *When a bit changed* Option.
- (4) Perform the following in the When a Bit Changed Dialog Box.
  - Select the *When a bit changed* option.
  - Enter *\$SB1* in the Address Field
  - Select the *Execute when ON* Option in the Action Timing Area.

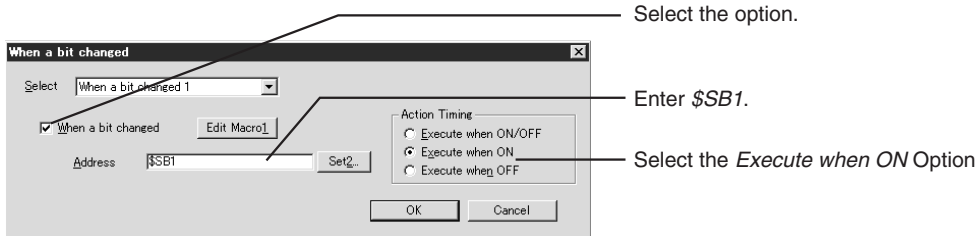

(5) Click the **Edit Macro** Button next to the *When a bit changed* Option.

(6) Enter the following macro and the click the **OK** Button.

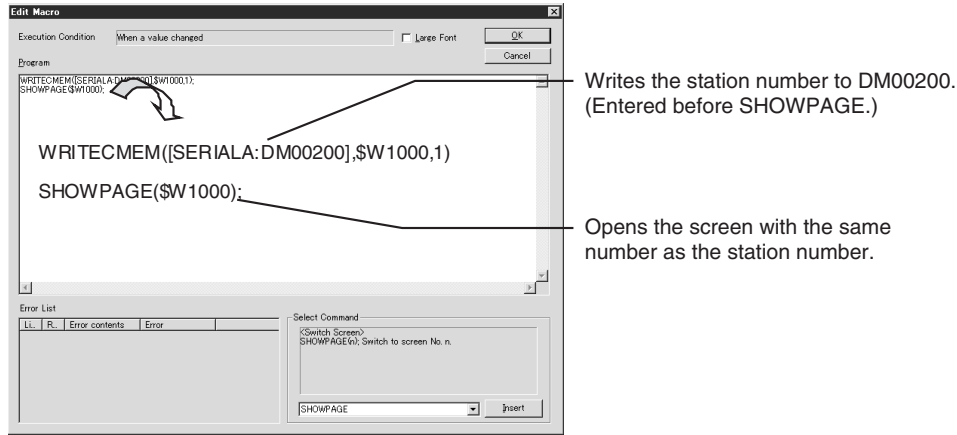

(7) After all settings have been entered, click the **OK** Button in the Edit Macro Dialog Box, in the When a Bit Changed Dialog Box, and in the Project Property Dialog Box to close them.

**Note** For detailed information on the macro function, refer to the *NS Series Macro Reference*.

5. Transferring Project Data

Connect the personal computer running CX-Designer to the NSH5 and transfer the project data (station number screen data and other items) to the NSH5.

6. Operation Check

Perform the following steps to check if the project data settings have been correctly entered.

(1) Connect the NSH5 to Removable Box 2 and turn ON the Removable Box key switch. The NSH5 will start.

When the NSH5 starts, the initial screen (screen 0) will be displayed. The number 2 will be stored in Station Status Monitor Address, \$W1000.

(2) Next, \$SB1 is turned ON, and the “When a bit changed” macro is executed.

The code “WRITEMEM(SERIALA:DM00200,\$W1000,1);” writes 2 to PLC address DM00200.

The code “SHOWPAGE(\$W1000);” changes the PT display to the screen for station 2 (screen 2).

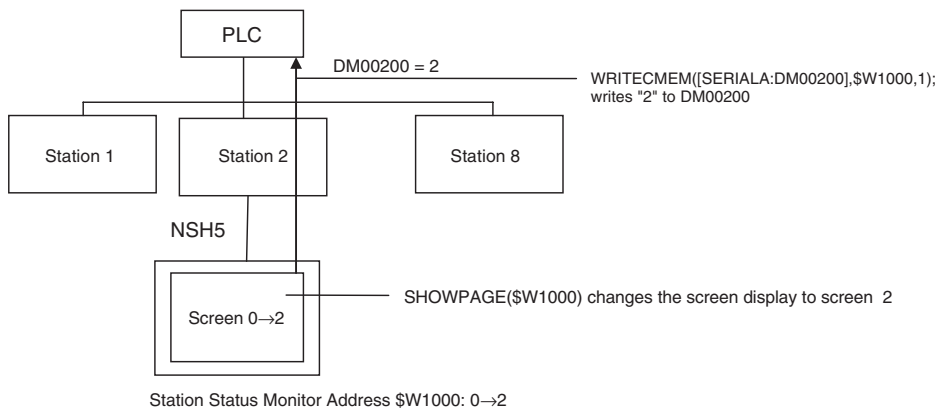

(3) Disconnect the NSH5 from Removable Box 2 and turn OFF the Removable Box's key switch. The power to the NSH5 will be turned OFF.

(4) The NSH5 is no longer connected, so DM00200 changes to 0.

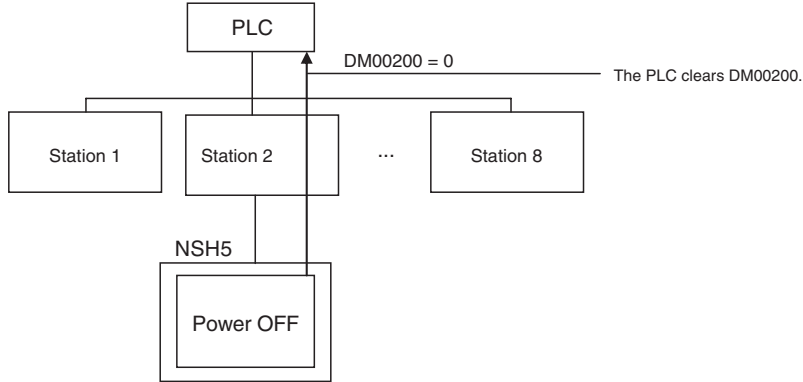

(5) Connect the NSH5 to Removable Box 1 and turn ON the Removable Box's key switch. The NSH5 will start. The number 1 is stored in Station Status Monitor Address, \$W1000.

(6) Next, \$SB1 is turned ON, and the "When a bit changed" macro is executed. The code "WRITECMEM(SERIALA:DM00200,\$W1000,1);" writes 1 to PLC address DM00200. The code "SHOWPAGE(\$W1000);" changes the PT display to the screen for station 1 (screen number 1).

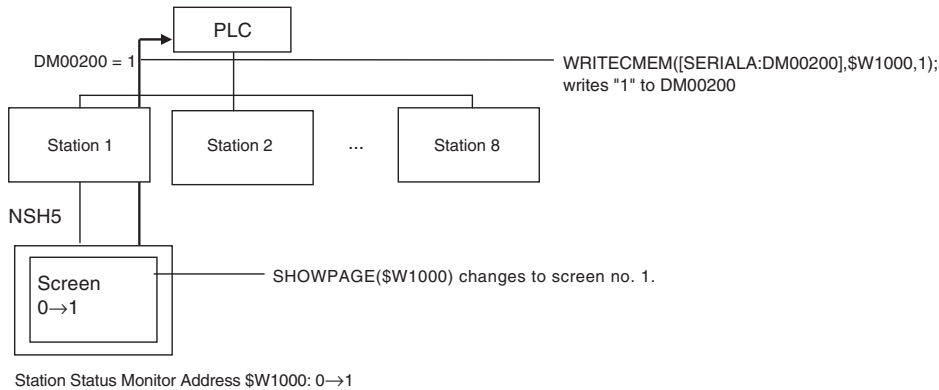

## Detection Method for NSH5 Disconnected Status

When the NSH5 is not connected to any Removable Box, the station number sent to the PLC must be cleared. Use one of the following methods to clear the station number.

- Monitoring the signal from the terminal block
- Monitoring \$SB0 and \$SB1 in NSH5 system memory
- Monitoring the Signal from the Terminal Block  
I/O connected to the Removable Box's terminal block terminals CONECT1 and CONECT2 turn ON while the NSH5 is connected to the Removable Box and turn OFF while the NSH5 is not connected. Therefore, add programming to the ladder diagram so that the PLC clears the station number stored in DM00200 when the I/O turns OFF.
- Monitoring \$SB0 and \$SB1 in NSH5 System Memory  
While the NSH5 is operating, \$SB0 in system memory is periodically turned ON and OFF and \$SB1 is always ON. As a result, if the NSH5 and PLC are connected, the PLC address allocated to \$SB0 is also periodically turned ON and OFF. Therefore, add programming to the ladder diagram so that the PLC clears the station number stored in DM00200 when the PLC address allocated to \$SB0 does not change for a specified period of time (indicating that the NSH5 and Removable Box are not connected).

## Connecting Multiple NSH5 PTs

The following description describes how to connect multiple NSH5 PTs. In this example, three NSH5 PTs are connected - stations No. 1 to No. 3. Use the following procedures to set up these units.

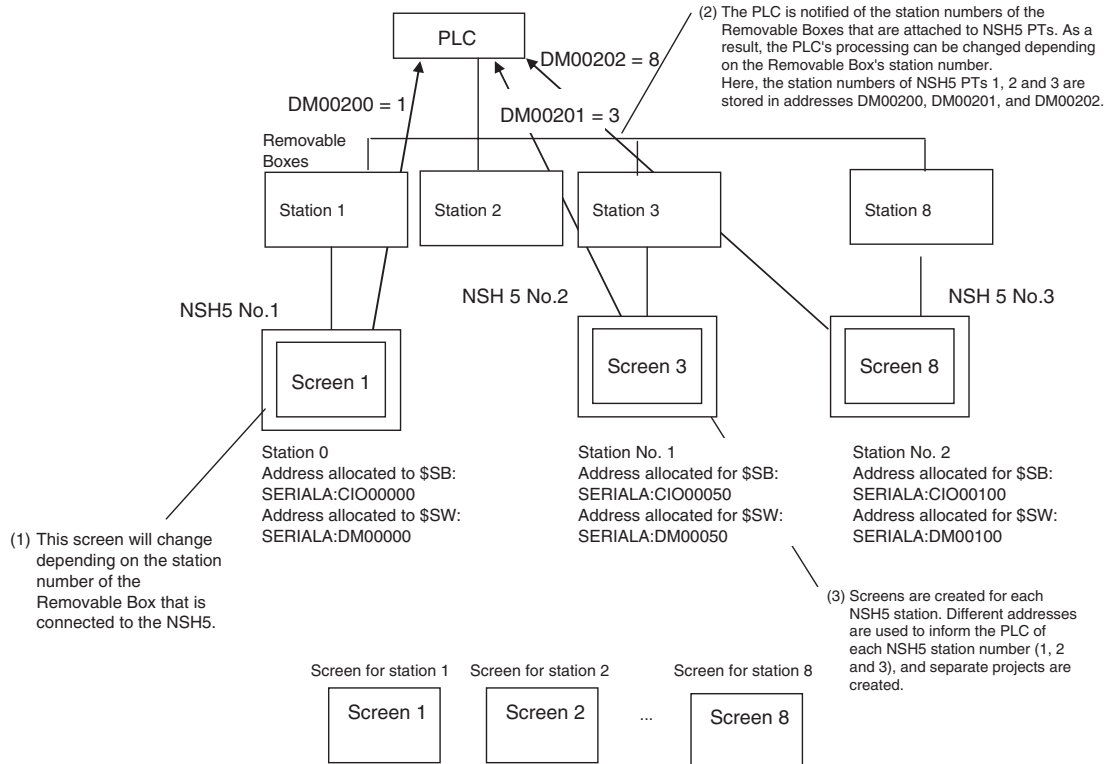

### 1. Removable Box Settings

The station number for each Removable Box is set using the rotary switch. For setting details, refer to 4-2 *Nomenclature and Functions* and Functions and 4-3 *Switch Settings*.

### 2. Station Status Monitor Address Settings

Use the following procedure to enter settings in the CX-Designer. These settings are for NSH5 No. 1.

- (1) Select **System Setting** from the CX-Designer's PT Menu.
- (2) Click the **NS Handy Terminal** Tab in the System Setting Dialog Box.
- (3) Enter **\$W1000** in the Station Status Monitor Address Field
- (4) Click the **OK** Button to close the System Setting Dialog Box.

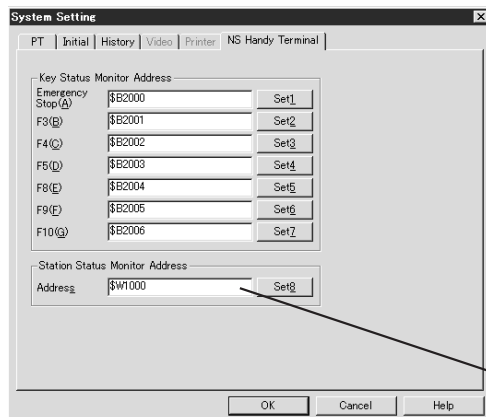

(3) Enter \$W1000 for the Station Status Monitor Address.

3. Creating Screens for Each Station

Create screens for stations so that the station numbers and the screen numbers match.

Screen number	Application
0	Initial screen (Displayed when NSH5 is started.)
1	Screen for Station 1
2	Screen for Station 2
---	---
8	Screen for Station 8

4. Macro Settings

Use the following steps to change screens depending on value changes of the Station Status Monitor Address and notify the PLC of the station number.

- (1) Select **Project Properties** from CX-Designer's PT Menu.
- (2) Click the **Macro** Tab in the Project Property Dialog Box.
- (3) Click the **Set** Button for the *When a bit changed* Option.
- (4) Perform the following in the When a Bit Changed Dialog Box.
  - Select the *When a bit changed* option.
  - Enter **\$SB1** in the Address Field
  - Select the *Execute when ON* Option in the *Action Timing Area*.

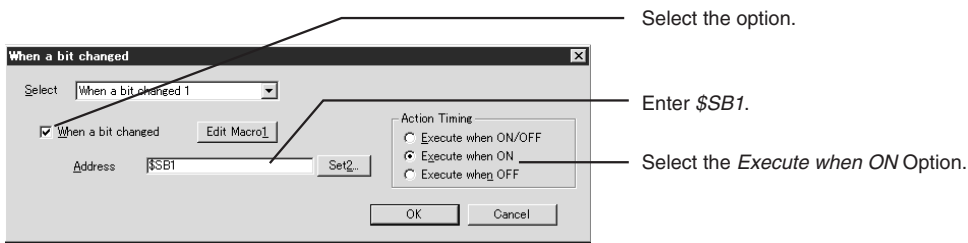

- (5) Click the **Edit Macro** Button next to the *When a bit changed* Option.
- (6) Enter the following macro and the click the **OK** Button.

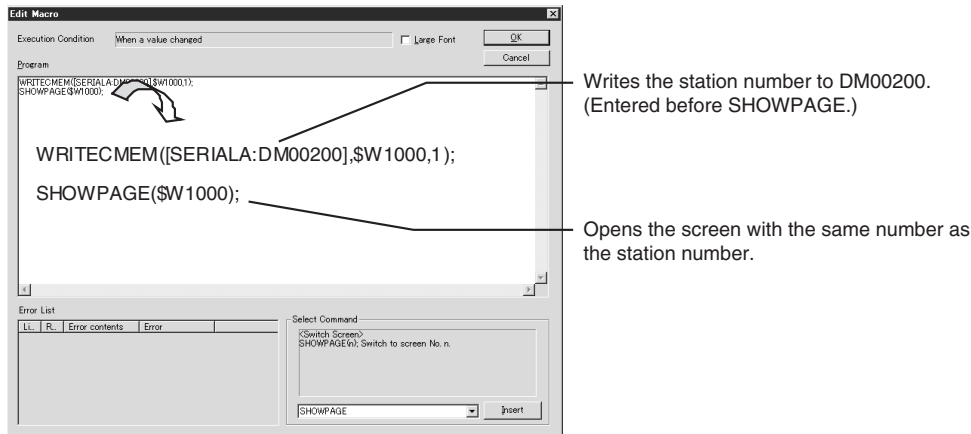

- (7) After all settings have been entered, click the **OK** Button in the Edit Macro Dialog Box, in the When a Bit Changed Dialog Box, and in the Project Property Dialog Box to close them.

**Note** For detailed information on the macro function, refer to the *NS Series Macro Reference*.

- (8) Select **System Setting** from the PT Menu.
- (9) Click the **Initial** Tab in the System Setting Dialog Box.

- (10) Enter *SERIALA:00000* in the *\$SB Allocation Address* Field and *SERIALA:DM00000* in the *\$SW Allocation Address* Field. Click the **OK** Button to close the dialog box.

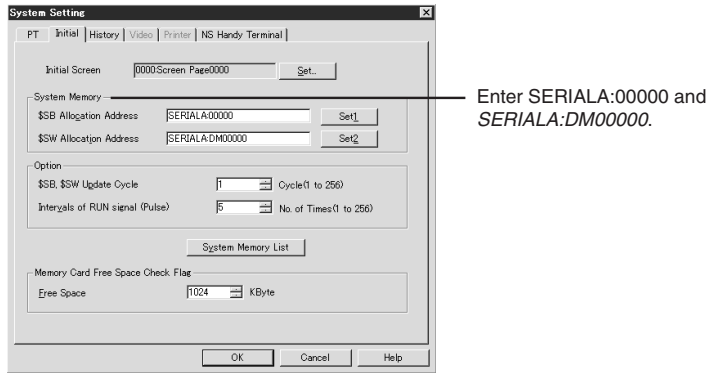

- (11) Select **Communication Setting** from the PT Menu.  
 (12) Double-click the **Serial Port A** Icon in the Comm. Setting Dialog Box.  
 (13) Enter *0* in the *NT Link(1:N) Unit No.* Field. Click the **OK** Button to close the dialog box.

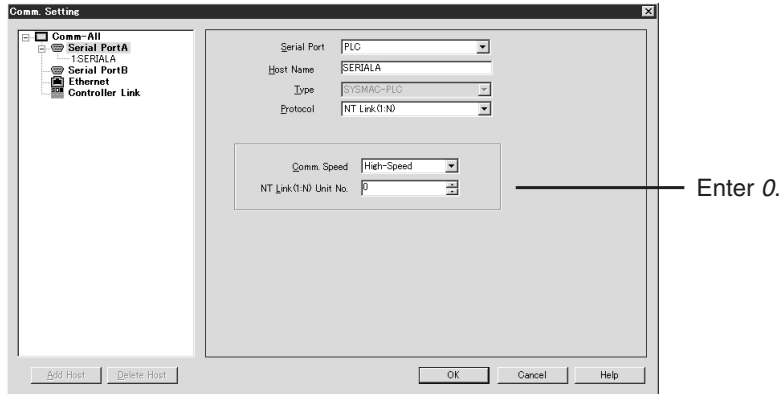

Use **Save Project As** on the CX-Designer File Menu to save the project data created so far for NSH5 No. 1 as separate projects for NSH5 No. 2 and NSH5 No. 3.

For each of the newly created project, use the following procedure to designate the PLC address that the station number will be sent to.

- (1) Select **Project Properties** from CX-Designer's PT Menu.
- (2) Click the **Macro** Tab in the Project Property Dialog Box.
- (3) Click the **Set** Button for the *When a bit changed* Option.
- (4) Click the **Edit Macro** Button next to the *When a bit changed* Option

(5) Edit the macro.

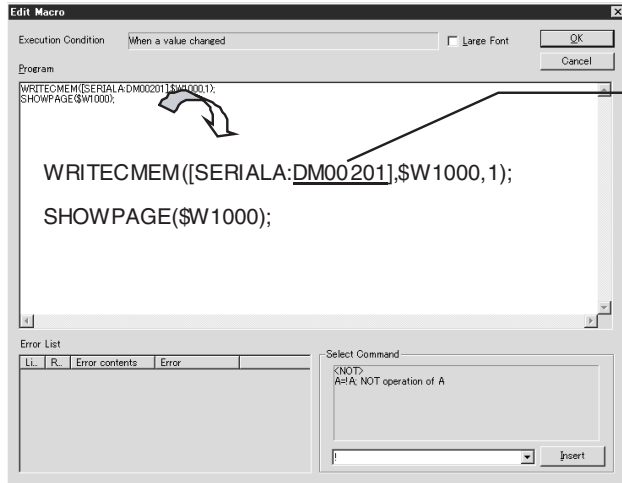

Change the station no. write destination.  
(For project No. 2 enter *DM00201*, and  
for No. 3 enter *DM00202*.)

PLC addresses are use for the following applications.

Address	Application
DM00200	Stores the station number of the Removable Box that is connected to NSH5 No. 1.
DM00201	Stores the station number of the Removable Box that is connected to NSH5 No. 2.
DM00202	Stores the station number of the Removable Box that is connected to NSH5 No. 3.

**Note** When entering the above macro for each NSH5 project, be sure the PLC write address is not used by any other project. Duplicate project addresses will result in the PLC not being able to correctly judge which NSH5 PT is connected to which Removable Box.

- (6) After all settings have been entered, click the **OK** Button in the Edit Macro Dialog Box, in the When a Bit Changed Dialog Box, and in the Project Property Dialog Box to close them.
- (7) Select **PT** from the System Setting Menu.
- (8) Click the **Initial** Tab in the System Setting Dialog Box.
- (9) Change the *\$SB Allocation Address* and the *\$SW Allocation Address* Fields. After entering the new data, click the **OK** Button to close the dialog box.

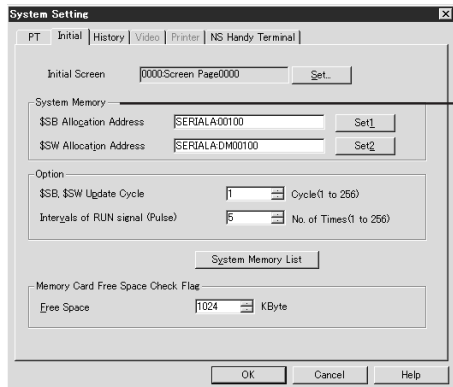

For NSH5 No. 2, enter *SERIALA:00050* and *SERIALA:DM00050*.  
For NSH5 No. 3, enter *SERIALA:00100* and *SERIALA:DM00100* in each of these addresses.

The settings entered for each NSH5 PT are as follows:

NSH5	System Memory Allocation
No.1	\$SB Allocation Address: SERIALA:CIO00000 \$SW Allocation Address: SERIALA:DM00000
No.2	\$SB Allocation Address: SERIALA:CIO00050 \$SW Allocation Address: SERIALA:DM00050
No.3	\$SB Allocation Address: SERIALA:CIO00100 \$SW Allocation Address: SERIALA:DM00100

- (10) Select **Communication Setting** from the PT Menu.
- (11) Double-click the **Serial Port A** Icon in the Comm. Setting Dialog Box.
- (12) Enter the desired setting in the *NT Link(1:N) Unit No.* Field. Click the **OK** Button to close the dialog box.

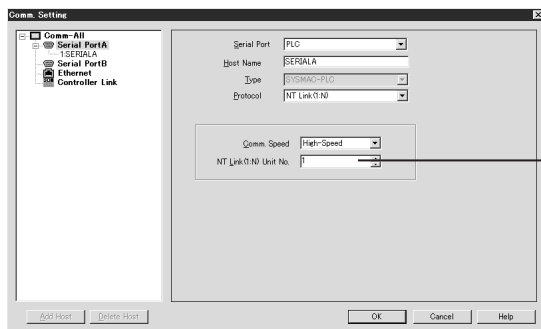

For NSH5 No. 2, enter "1".  
For NSH5 No. 3, enter "2".

Enter the following numbers for each NSH5 PT.

NSH5	Station number
No.1	0
No.2	1
No.3	2

**Note** If more than one NSH5 PT is connected at the same time, be sure not to set the system memory addresses or station numbers for more than one PT. If system memory addresses are duplicated, operation problems can occur, such as all NSH5 PTs displaying the same screen.

- 5. Transferring Project Data  
Connect the personal computer running CX-Designer to the NSH5 and transfer the project data (station number screen data and other items) to the NSH5.
- 6. Operation Check  
Perform the following steps to check if the project data settings have been correctly entered.
  - (1) Connect NSH5 PTs 1, 2, and 3 to Removable Boxes 1, 3, and 8, respectively, and turn ON each Removable Box key switches. The NSH5 PTs will start. After each NSH5 PT starts, the initial display screen (screen 0) will appear. Also, the numbers 1, 3, and 8 will be stored in the Station Status Monitor Address, \$W1000, for NSH5 PTs 1, 2, and 3, respectively.
  - (2) After \$SB1 is turned ON in each NSH5 PT, the "When a bit changed" macro is executed. In NSH5 No. 1, the code "WRITECMEM(SERIALA:DM00200, \$W1000,1);" writes 2 to DM00200, and the code "SHOWPAGE(\$W1000);" changes the screen to the screen for station number 2 (screen 2). Similarly, NSH5 No. 2 writes 3 to DM00201, which displays screen 3. Finally, NSH5 No. 3 writes 8 to DM00202, which displays screen 8.



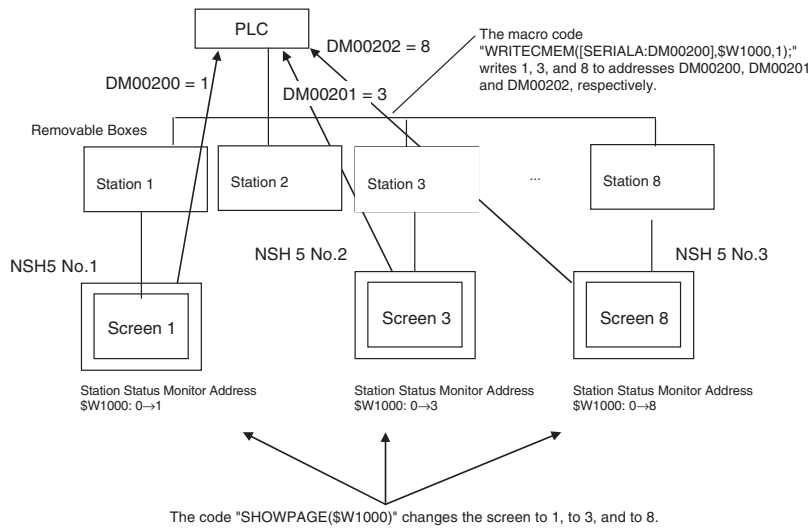

**Note** The operation for disconnecting and re-connecting any of the NSH5 PTs is the same as with a single NSH5 PT.

## Detection Method for NSH5 Disconnected Status

When the NSH5 is not connected to any Removable Box, the station number sent to the PLC must be cleared. Use one of the following methods to clear the station number.

- Monitoring the signal from the terminal block
- Monitoring \$SB0 and \$SB1 in NSH5 system memory
- Monitoring the Signal from the Terminal Block  
I/O connected to the Removable Box's terminal block terminals CONECT1 and CONECT2 turn ON while the NSH5 is connected to the Removable Box and turn OFF while the NSH5 is not connected. Therefore, add programming to the ladder diagram so that the PLC clears the station number stored in DM00200, DM00201, and DM00202 when the I/O turns OFF.
- Monitoring \$SB0 and \$SB1 in NSH5 System Memory  
While the NSH5 is operating, \$SB0 in system memory is periodically turned ON and OFF and \$SB1 is always ON. As a result, if the NSH5 and PLC are connected, the PLC address allocated to \$SB0 is also periodically turned ON and OFF. Therefore, add programming to the ladder diagram so that the PLC clears the station number stored in DM00200, DM00201, and DM00202 when the PLC address allocated to \$SB0 does not change for a specified period of time (indicating that the NSH5 and Removable Box are not connected).

## Revision History

A manual revision code appears as a suffix to the catalog number on the front cover of the manual.

Cat. No. V090-E1-06

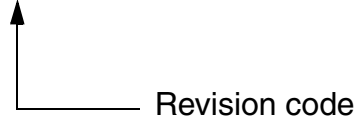

The following table outlines the changes made to the manual during each revision. Page numbers refer to the previous version.

Revision code	Date	Revised content
01	December 2005	Original production
02	January 2006	<b>Page 25:</b> Step 3 added at bottom of page. <b>Page 38:</b> Tables replaced at bottom of page. <b>Page 51:</b> Mounting bracket dimensions added.
03	April 2006	Revised to reflect UL standard certification, Special Cable model added, and new PT model added.
04	May 2006	<b>Cover:</b> "NSH5-SQG00B-V2" added. <b>Pages 3, 4, 5, 9, 36, and 57:</b> Emergency stop switch contact structure corrected.
05	August 2006	Revised to add Removable Box.
06	July 2007	<b>Page 44:</b> Rewrote <i>Replacing System Programs</i> section. <b>Page 46:</b> Removed procedure at bottom of page and replace paragraph above it. <b>Page 47:</b> Removed second paragraph in <i>3-7 Screen Saver Prohibit Function</i> and replaced paragraph after it. <b>Page 48:</b> Added note 2.

---

*Revision History*

---