

General-Purpose Rotary Encoder Withstands Large Shaft Loads

- Wide variety of supply voltages and output forms
- Easy-to-adjust zero index (phase Z) with origin indicating function
- High resolution models (2000 pulses per revolution) substantially improves measuring accuracy
- Rugged construction: 6 mm (0.24 inch) diameter shaft with radial load ratings of 3 kgf (21.7 ft.-lbs.) and axial load rating of 2 kgf (14.5 ft.-lbs.)
- Protected against short-circuit and reversed connections for highly reliable operation
- Replaces Omron E6B encoders
- Available with Line Driver output



Ordering Information

■ ENCODERS

When ordering, add the resolution (pulses per revolution) between the part number and cable length. For example, **E6B2-CWZ3E 360 P/R 0.5M**. Standard stock products are shown in bold in the Part Number Index.

Resolution (pulses per revolution)	Output phases	Output form	Supply voltage	Part number
10, 20, 30, 40, 50, 60, 100, 200, 300, 360, 400, 500, 600, 1000, 1200, 1500, 1800, 2000	A, B, Z (reversible)	Open collector	5 to 24 VDC	E6B2-CWZ6C □□□P/R 0.5M
	A, B, Z (reversible)	Voltage	5 to 12 VDC	E6B2-CWZ3E □□□P/R 0.5M
	A, \bar{A} , B, \bar{B} , Z, \bar{Z} (reversible)	Line driver	5 VDC	E6B2-CWZ1X □□□P/R 0.5M

■ ACCESSORIES

Description	Part number	
Shaft coupler	Fits one 6 mm (0.24 in.) and 8 mm (0.32 in.) dia. shaft	E69-C68B
	Fits one 6 mm (0.24 in.) and 10 mm (0.39 in.) dia. shaft	E69-C610B
Mounting flange	E69-FBA	
Mounting bracket, set of three	E69-FBA-02	

■ REPLACEMENT PARTS

Description	Part number	
Shaft coupler	Fits two 6 mm (0.24 in.) dia. shafts; supplied with each encoder.	E69-C06B

Specifications

Part number	E6B2-CWZ3E	E6B2-CWZ6C	E6B2-CWZ1X
Supply voltage	5 VDC -5% to 12 VDC +10%; max. 5% ripple peak-to-peak	12 VDC -10% to 24 VDC +15%; max. 5% ripple	5 VDC ±5%
Current consumption	100 mA max.	80 mA max.	160 mA max.
Resolution (pulses per revolution)	10, 20, 30, 40, 50, 60, 100, 200, 300, 360, 400, 500, 600, 1000, 1200, 1500, 1800, 2000		
Output phases	A, B, Z (reversible)	A, B, Z (reversible)	A, \bar{A} , B, \bar{B} , Z, \bar{Z} (reversible)
Output form	Voltage output	Open collector output	Line driver output
Output capacity	Output resistance: 2 k Ω Residual voltage: 0.4 V max. Sink current: 20 mA max.	Applied voltage: 30 VDC max. Residual voltage: 0.4 V max. Sink current: 35 mA max.	AM26LS31 Output current: High level: -20 mA Low level: +20 mA Output voltage: High voltage: 2.5 V minimum Low voltage: 0.5 V maximum
Maximum response frequency	100 kHz		
Rotation direction	Reversible, CW + CCW		
Phase difference of output	90° ±45° between A and B (1/4T ±1/8T)		
Output rise and fall times	1 μ s max. with cable length: 0.5 m (1.64 ft.) sink current: 10 mA max.	1 μ s max. with control output voltage: 5 V load resistance: 1 k Ω cable length: 0.5 m (1.64 ft.)	0.1 μ s max. with cable length: 0.5 m (1.64 ft.) output current high: -20 mA output current low: +20 mA
Starting torque	10 g-cm (0.14 oz.-inch) max.		
Shaft loading	Radial	3 kgf (21.7 ft.-lbs.)	
	Axial	2 kgf (14.5 ft.-lb.)	
Moment of inertia	10 g-cm ² (0.055 oz.-inch ²) max.; 3 g-cm ² (0.0165 oz.-inch ²) max. at 600 pulses/revolution		
Maximum rpm	6,000 rpm		
Electrical connection	Prewired with 0.5 m (1.64 ft.) length cable		
Weight	Approx. 100 g (3.5 oz.) with cable		
Enclosure rating	IEC: IP50 (The E6B2 encoder is not watertight or oil resistant.)		
Ambient temperature	Operating	-10° to 70°C (14° to 158°F)	
	Storage	-25° to 80°C (-13° to 176°F)	
Ambient humidity	35 to 85% RH		
Vibration resistance	Mechanical durability: 10 to 500 Hz, 15 G or 2-m double amplitude, in X, Y, and Z directions for 11 minutes, three times each		
Shock resistance	Mechanical durability: 1000 m/s ² (approx. 100 G) in X, Y, and Z directions, 3 times each		
Insulation resistance	1000 M Ω minimum at 500 VDC between current-carrying part and housing		
Dielectric strength	500 VAC, 50/60 Hz for 1 minute between current-carrying part and housing		

Note:

The maximum electrical response revolution is determined by the resolution and maximum response frequency as follows:

Maximum electrical response frequency (rpm) = Maximum response frequency ÷ resolution × 60

This means that the E6B2 encoder will not operate electrically if its shaft speed exceeds the maximum electrical response revolution.

■ OUTPUT CIRCUIT DIAGRAMS

Open Collector Output E6B2-CWZ6C

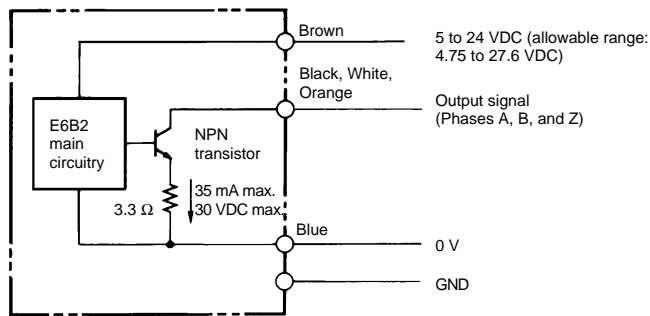

Wire Color Code

IEC colors are shown.

Color	Terminal
Brown	Power supply (+V)
Black	Output phase A
White	Output phase B
Orange	Output phase Z
Blue	0 V (common)

Voltage Output E6B2-CWZ3E

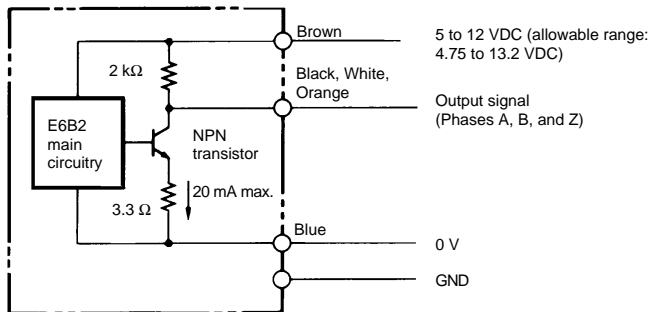

Wire Color Code

IEC colors are shown.

Color	Terminal
Brown	Power supply (+V)
Black	Output phase A
White	Output phase B
Orange	Output phase Z
Blue	0 V (common)

Line Driver Output E6B2-CWZ1X

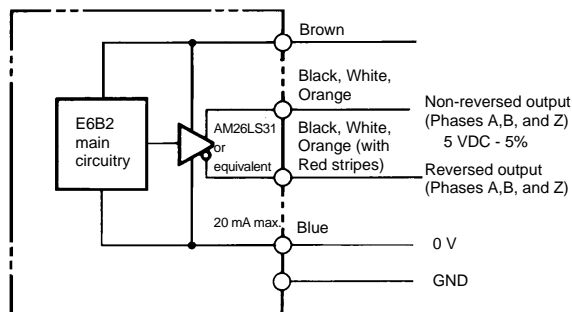

Wire Color Code

IEC colors are shown.

Color	Terminal
Brown	Power supply (+V)
Black	Output phase A
White	Output phase B
Orange	Output phase Z
Black/red stripes	Output phase \bar{A}
White/red stripes	Output phase \bar{B}
Orange/red stripes	Output phase \bar{Z}
Blue	0 V (common)

Note:

Both open collector and voltage output models of E6B2 have a circuit to prevent damage from a short-circuited load and reversed connection.

■ TIMING CHARTS

Open Collector Output E6B2-CWZ6C

Direction of rotation: CW
Clockwise as viewed from the shaft → CW direction

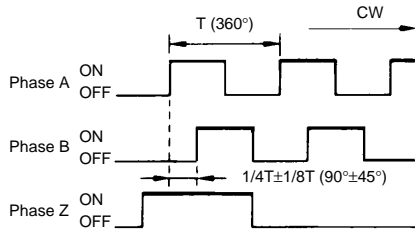

Note:
Phase A is $1/4T \pm 1/8T$ faster than phase B. The ONs in the above timing chart mean that the output transistor is ON and the OFFs mean that the output transistor is OFF.

Direction of rotation: CCW
Counterclockwise as viewed from the shaft → CCW direction

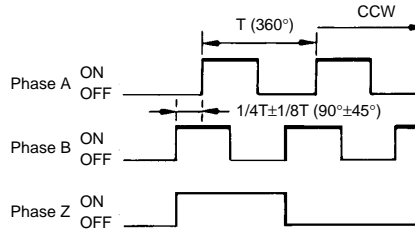

Note: Phase A is $1/4T \pm 1/8T$ slower than phase B.

Voltage Output E6B2-CWZ3E

Direction of rotation: CW
Clockwise as viewed from the shaft → CW direction

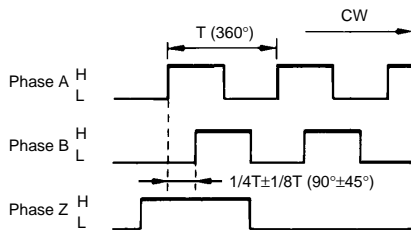

Note: Phase A is $1/4T \pm 1/8T$ faster than phase B

Direction of rotation: CCW
Counterclockwise as viewed from the shaft → CCW direction

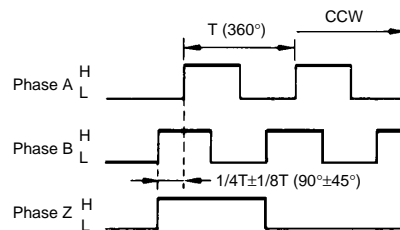

Note: Phase A is $1/4T \pm 1/8T$ slower than phase B.

Line Driver Output E6B2-CWZ1X

Direction of rotation: CW
Clockwise as viewed from the shaft → CW direction

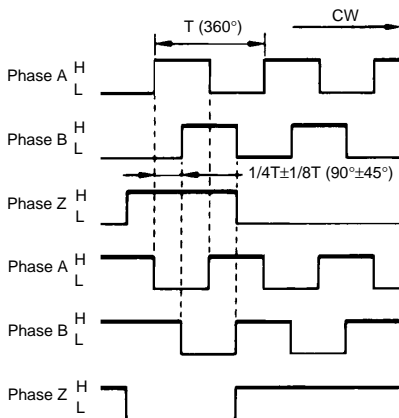

Note:
The line driver output circuit is an RS-422A data transmission circuit consisting of two balanced output lines. The relationship between the two output lines is on an equal status. This means that if the level of the signal on a line is H, the level of the signal on the other line is L. The noise-resistant line driver output circuit assures high-speed data transmission.

Direction of rotation: CCW
Counterclockwise as viewed from the shaft → CCW direction

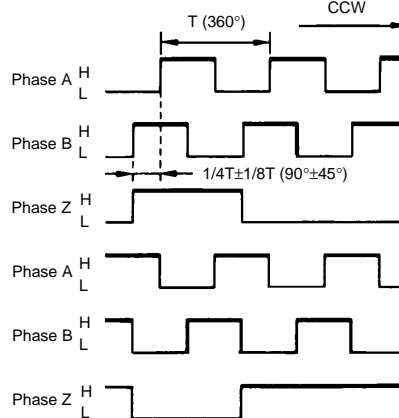

Dimensions

Unit: mm (inch)

ENCODERS

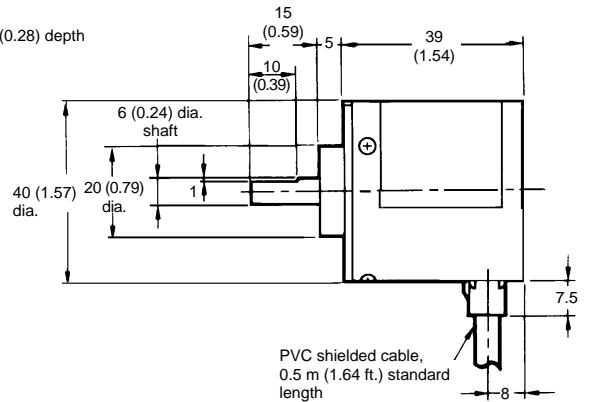
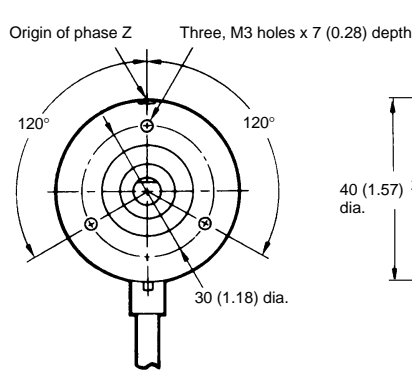
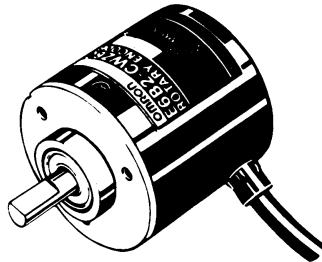

ACCESSORIES

Shaft Coupler E69-C06B (included) for two 6 mm diameter shafts

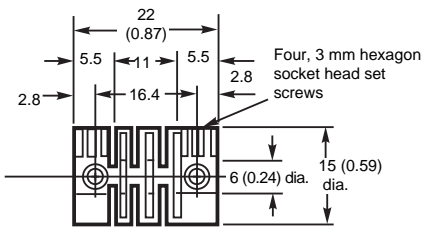

Shaft Coupler E69-C68B for one 6 mm and one 8 mm diameter shaft

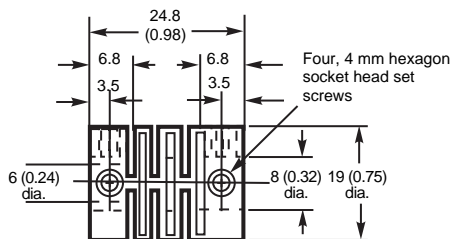

Shaft Coupler E69-C610B for one 6 mm and one 10 mm diameter shaft

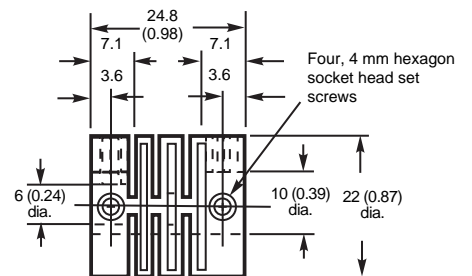

Note:

1. Material: Glass-filled polybutadiene terephthalate (PBT).
2. An E69-C06B coupler is supplied with each E6B2 encoder.
3. Each set screw must be tightened to 2.5 kg-cm (2.17 in-lbs.).

Mounting Flange E69-FBA

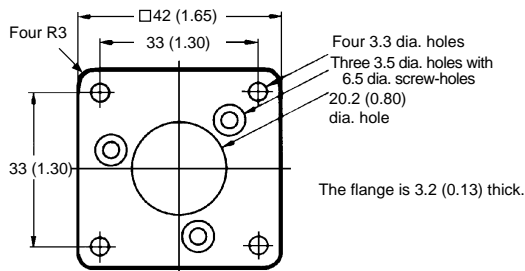

Dimensions with Encoder

Three, 3.5 dia. holes with 6.5 dia. countersink

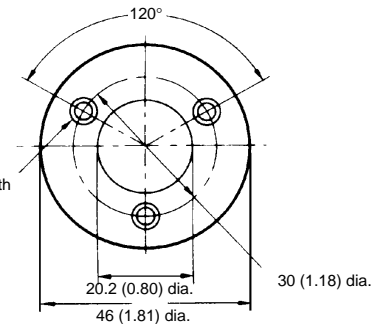

Mounting Bracket E69-FBA-02

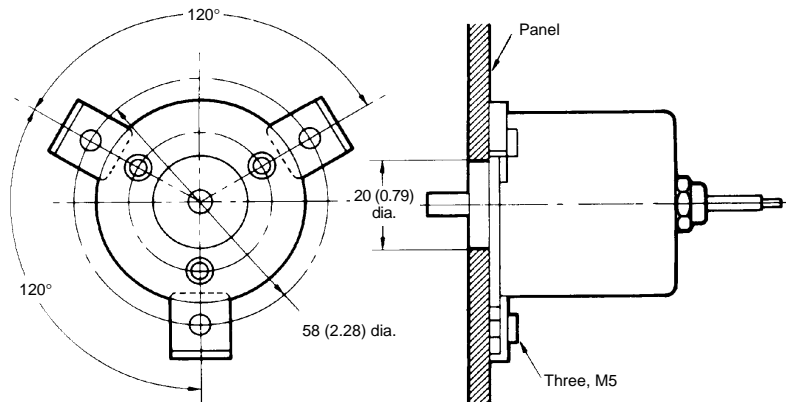
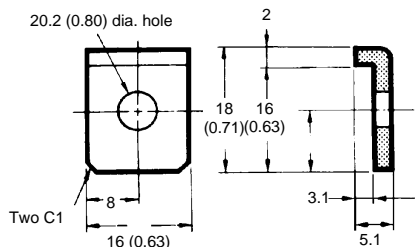

Installation

INPUT TO MORE THAN ONE COUNTER FROM ENCODER WITH VOLTAGE OUTPUT

Use the following formula to obtain the number of counters to be connected to a single E6B2

$$\text{Number of counters (N)} = \frac{R1 (E-V)}{V \times R2}$$

- E: Voltage supplied to Rotary Encoder
 V: Minimum input voltage of the counter
 R2: Output resistance of the Rotary Encoder
 R1: Input resistance of the Rotary Encoder

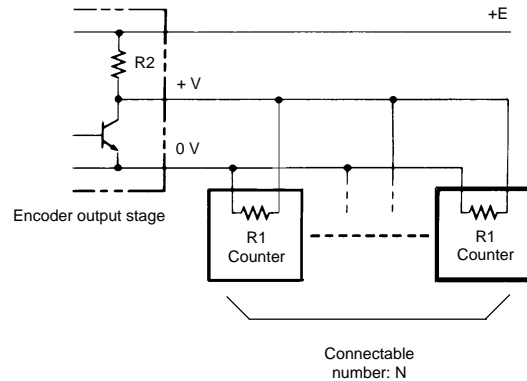

ORIGIN INDICATION

It is easy to adjust the position of phase Z with the origin indication function. The following illustration (on the left-hand side) shows the relationship between phase Z and the origin. Set cut face D to the origin as shown in the illustration (on the right-hand side).

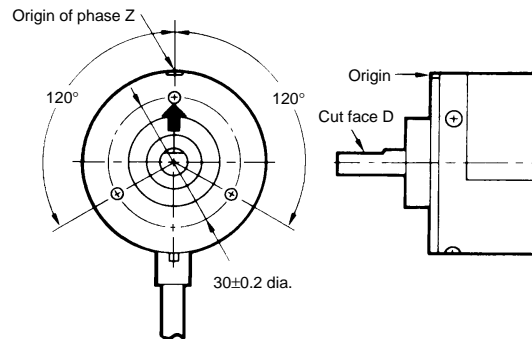

CONNECTION WITH PERIPHERAL DEVICES

Encoder	E6B2-CWZ3E	E6B2-CWZ6C	E6B2-CWZ1X
Digital Counter (H7BR, H7CR)	A	A	C
Digital Tachometer (H7ER)	A	A	C
Intelligent Digital Panel Meter (K3TR-NB□□□□)	B	B	C
Line receiver IC	C	C	A
SYSMAC High-speed Counter Module	A	A	A
SYSMAC Position Control Module	B	B	A
TTL, LSTTL	A	A	C
CMOS	A	A	C
Sensor Controller, S3D8	B	A	C
Sensor, Controller, S3D2	A	A	C
Direction Sensor Unit, E63-WF5C	A	A	C

Legend:

- A: Possible to connect directly in most cases.
 B: Possible to connect, but an independent power supply or pull-up resistor will be required.
 C: Impossible to connect.

NOTE: DIMENSIONS ARE IN MILLIMETERS. To convert millimeters to inches, divide by 25.4.

OMRON

Omron Europe B.V. EMA-ISD, tel:+31 23 5681390, fax:+31 23 5681397, <http://www.eu.omron.com/ema>