

YK250~400XP

Dust-proof & drip proof Type

Arm length 250•350•400mm/Maximum payload 3kg

Robot ordering method

YK250XP - 150 - 3L - RCX142 - E - N1 - CC - S

Model: YK250XP, 350, 400
 Z axis stroke: 150:150mm
 Cable length: 3L:3.5m, 5L:5m, 10L:10m
 Controller: RCX142
 CE: Blank/Standard, E/CE specification
 Expansion I/O: N1
 Network: CC
 Battery: S

Controller type: Refer to the Controller Catalog for further details.
 * Built-to-order product. Contact us for the delivery period.

Basic specifications

Model		YK250XP	YK350XP	YK400XP
Axis specifications	X axis	Arm length	125mm	225mm
		Rotation range	± 115°	
	Y axis	Arm length	125mm	175mm
		Rotation range	± 130°	± 140°
	Z axis	Stroke	150mm	
R axis	Rotation range	± 180°		
Motor	X axis	200W		
	Y axis	100W		
	Z axis	100W		
	R axis	100W		
Maximum speed	X, Y combined	4.0m / s	5.0m / s	6.0m / s
	Z axis	1.0m / s		
	R axis	1020° / s		
Repeatability*1	X, Y axis	± 0.01mm		
	Z axis	± 0.01mm		
	R axis	± 0.005°		
Max. payload		3kg		
Standard cycle time (with 2kg payload)		0.54 sec.	0.66 sec.	
R axis allowable moment inertia*2		0.049kgm ² (0.5kgfcm ²)		
User wiring		0.2sq × 10 wires		
User tubing		ø4 × 3		
Movement limit setting		1. Soft limit, 2. Mechanical limit (X, Y, Z axes)		
Robot cable		Standard 3.5m Option: 5m, 10m		
Controller, Power supply capacity		RCX142, 1000VA		
Weight		15kg		

*1: This is the value at a constant ambient temperature. (X, Y axes)
 *2: There are limits to the setting of the acceleration coefficient.



YK400XP

YK250XP

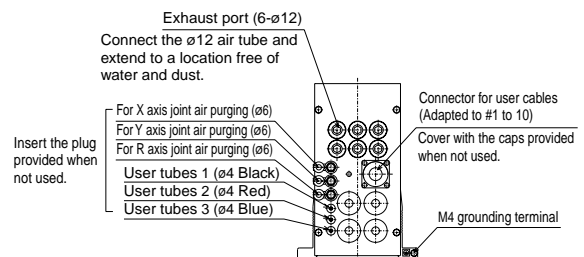
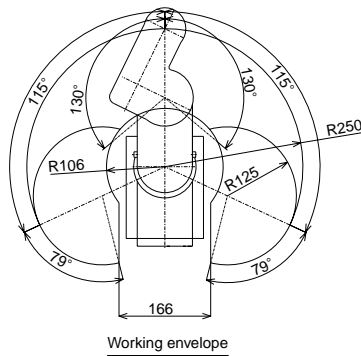
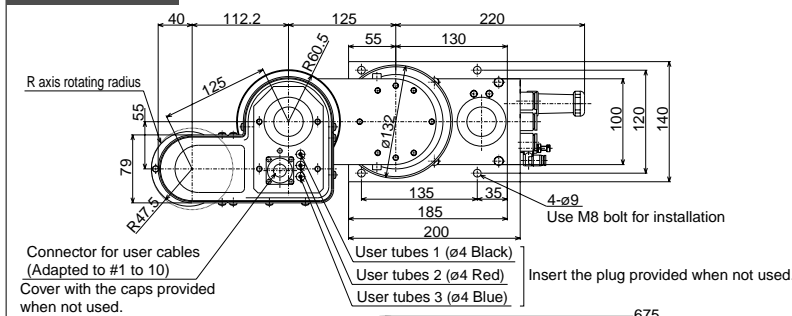

YK350XP

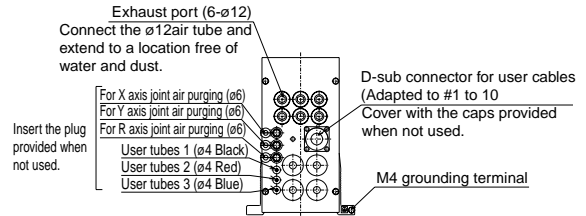
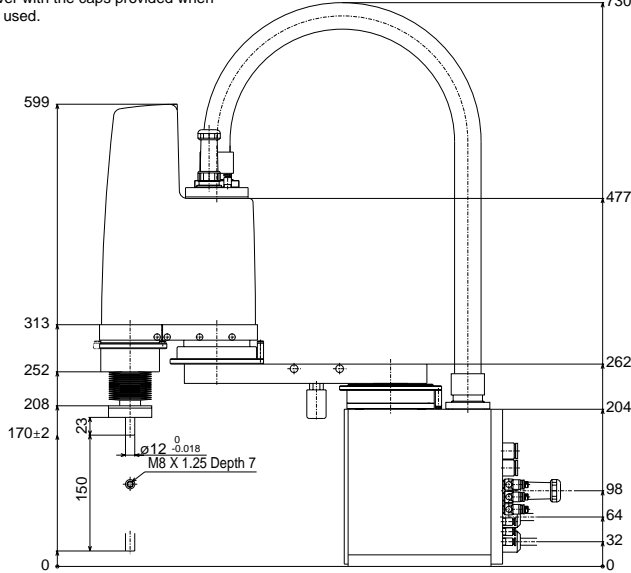
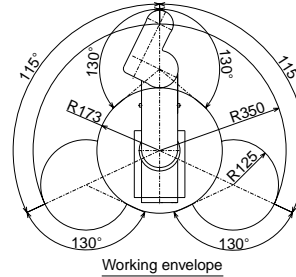
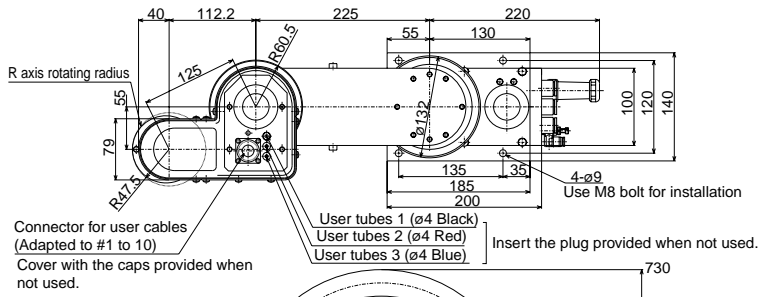

YK400XP

