

Compact Count or Time Totalizers  
with Easy-to-Read Display and  
NEMA 4 Protection

- High-visibility, 8.5 mm negative transmissive LCD.
- NEMA 4 protection when used in conjunction with Y92S-32 rubber gasket supplied with each unit.
- Short (80 mm) body.
- Switch between NPN and PNP operation.
- Both external and manual resets provided.



### Ordering Information

Supply voltage	6-digit totalizing counter		6-digit time totalizer	
	Light gray	Black	Light gray	Black
100 to 240 VAC	<b>H7GP-C</b>	<b>H7GP-CB</b>	<b>H7GP-T</b>	<b>H7GP-TB</b>
12 to 24 VDC	<b>H7GP-CD</b>	<b>H7GP-CDB</b>	<b>H7GP-TD</b>	<b>H7GP-TDB</b>

#### MODEL NUMBER LEGEND:

H7GP-□□□

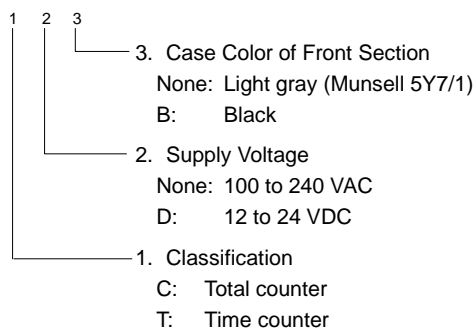

#### REPLACEMENTS

Model	Part number
Rubber gasket (supplied)	<b>Y92S-32</b>
Panel mount adapter	<b>Y92F-32</b>

Note: See panel mounting note on page 7.

# Specifications

## ■ GENERAL CAPABILITIES

Model	H7GP-C	H7GP-CD	H7GP-T	H7GP-TD
Classification	6-digit total counter		6-digit time counter	
Mounting method	Flush mounting			
External connections	Screw terminals			
Enclosure ratings	Panel surface: JEM IP66G and NEMA Type 4 (indoors) when used with Y92S-32 rubber gasket.			
Input mode	Up (increment)		Accumulative	
Reset system	External and manual resets			
External power supply	50 mA at 12 VDC	---	50 mA at 12 VDC	---
Input signals	Count, reset, and key protection		Start, reset, and key protection	
Input method	No-voltage input (NPN transistor input) or voltage input (PNP transistor input) (selectable)			
Display	7-segment, negative transmissive LCD (with red backlight)			
Digits	6 digits (8.5 mm characters)			
Memory backup	EEPROM: 200,000 operations min.			

## ■ RATINGS

Supply voltage	100 to 240 VAC 50/60 Hz	12 to 24 VDC permissible ripple 20% (p-p) max.	100 to 240 VAC 50/60 Hz	12 to 24 VDC permissible ripple 20% (p-p) max.	
Operating voltage range	85% to 110% of rated supply voltage				
Power consumption	100 to 240 VAC: 6.5 VA max., 12 to 24 VDC: 0.6 W max.				
Max. counting speeds	30 cps or 5 Kcps (selectable)		---		
Inputs	Reset	20 or 1 ms (automatic according to count speed)		20 ms	
	Start	---		20 ms	
	Key protection	Approx. 1 s (see note 1)		Approx. 1 s (see note 1)	
	Count, reset, start	No-voltage input (NPN transistor input) Short-circuit (ON) impedance: 1 K $\Omega$ max. Short-circuit (ON) residual voltage: 2 VDC max. Open (OFF) impedance: 100 k $\Omega$ min.  Voltage input (PNP transistor input) Short-circuit (ON) impedance: 1 K $\Omega$ max. ON voltage: 9 to 24 VDC OFF voltage: 5 VDC max. Open (OFF) impedance: 100 k $\Omega$ min.			
	Key protection	No-voltage input (NPN transistor input) Short-circuit (ON) impedance: 1 K $\Omega$ max. Short-circuit (ON) residual voltage: 0.5 VDC max. Open (OFF) impedance: 100 k $\Omega$ min.			

Note: 1. Only a non-voltage input (NPN transistor) is possible for the key protection input. Switching between NPN and PNP inputs does not affect key protection function. A PNP input cannot be used.

## ■ CHARACTERISTICS

Insulation resistance		100 M $\Omega$ min. (at 500 VDC)	
Dielectric strength		2,000 VAC, 50/60 Hz for 1 min between current-carrying terminal and exposed non-current-carrying metal parts (AC model) 1,000 VAC, 50/60 Hz for 1 min between current-carrying terminal and exposed non-current-carrying metal parts (DC model) 2,000 VAC, 50/60 Hz for 1 min between power terminals and control input terminals (AC model)	
Impulse withstand voltage		3 kV (between power terminals) (1 kV for 12-to-24-VDC models) 4.5 kV (between current-carrying terminal and exposed non-current-carrying metal parts) (1.5 kV for 12-to-24-VDC models)	
Noise immunity		$\pm$ 1.5 kV (between AC power terminals), $\pm$ 480 V (between DC power terminals), $\pm$ 480 V (between input terminals); square-wave noise by noise simulator (pulse width: 100 ns/1 $\mu$ s, 1-ns rise)	
Static immunity	Display	Malfunction	8 kV
		Destruction	15 kV
	Dip switch	Malfunction	4 kV
		Destruction	8 kV
Vibration resistance		Malfunction	10 to 55 Hz with 0.5-mm single amplitude each in three directions
		Destruction	10 to 55 Hz with 0.75-mm single amplitude each in three directions
Shock resistance		Malfunction	196 m/s <sup>2</sup> (20G) each in three directions
		Destruction	294 m/s <sup>2</sup> (30G) each in three directions
Ambient temperature		Operating: -10 to 55°C (14 to 131°F) with no icing Storage: -25 to 65°C (-13 to 149°F) with no icing	
Ambient humidity		Operating: 35% to 85%	
Approved standards		UL508, CSA22.2 No.14	
Case color		Rear section: Gray smoke; Front section: 5Y7/1 (light gray) or N1.5 (black)	
Weight		Approx. 76 g (2.68 Oz)	

## Nomenclature

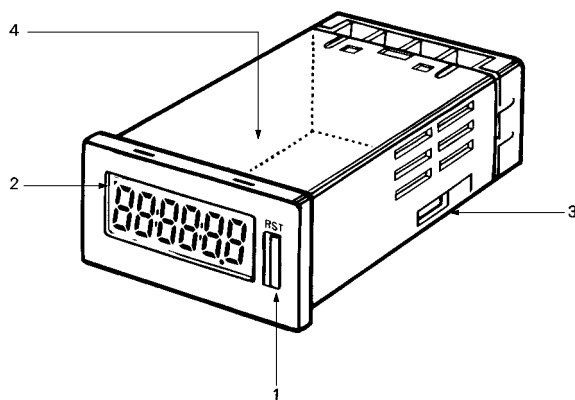

1. **Reset Key**  
Resets the count value, but will not operate while the keys are protected.
2. **Key Protection Indicator**  
Lit while the keys are protected.
3. **NPN/PNP DIP Switch**  
(Count or start with reset)  
When setting is changed, cycle power to continue.  
Display reads "0" when power is applied.
4. **Counting Speed DIP Switch (H7GP-C)**  
**Time Range DIP Switch (H7GP-T)**  
When setting is changed, cycle power to continue.  
Display reads "0" when power is applied. Refer to DIP switch settings for details.

# Operation

## ■ DIP SWITCH SETTINGS

Set all DIP switches before mounting the Counter to a control panel. All switches are set toward the display panel before shipping.

### H7GP-C

Switch	Item	Function	
		Display side	NPN
3 (On right side from front)	Input mode (note 1)	Terminal side	PNP
		Display side	NPN
4 (On left side from front)	Counting speed (note 1)	Terminal side	5 kHz
		Display side	30 Hz

Note: 1. When setting is changed cycle power to continue. Display reads "0" when power is applied.

### H7GP-T

Switch	Item	Function	
		Display side	NPN
3 (On right side from front)	Input mode (note 1)	Terminal side	PNP
		Display side	NPN
4 (On left side from front)	Time range	Terminal side	99 h 59 m 59 s
		Display side	99999.9h (note 2)

Note: 1. When setting is changed cycle power to continue. Display reads "0" when power is applied.

2. The decimal point will flash every second when "99999.9 h" is set.

## ■ OPERATING MODES

### Total Counters

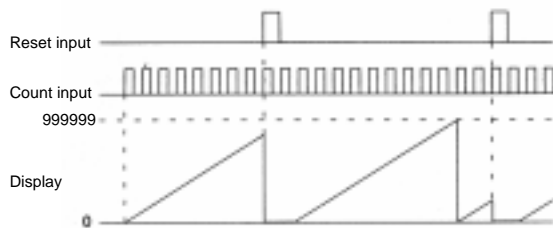

### Time Counters

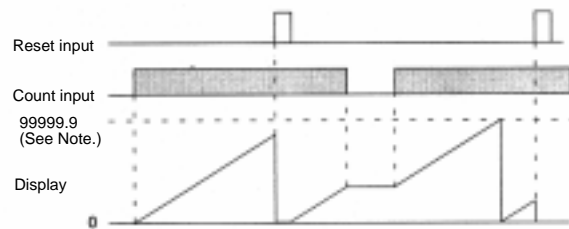

Note: Display values are shown for full scale set to 99999.9 h.

# Dimensions

Unit: mm (inch)

### H7GP-C H7GP-T

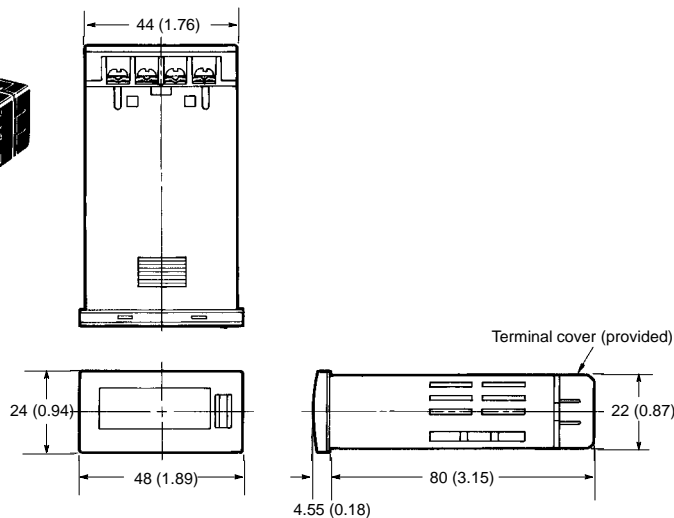
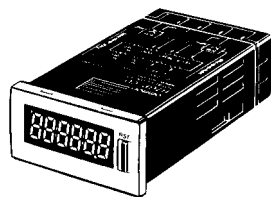

### Panel Cutouts

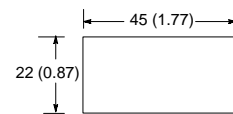

- Note: 1. Recommended panel thickness is 1 to 6 mm (0.4 to 0.24 inch) panel cutout conforms to DIN 43700.
2. NEMA 4 protection lost if mounted side by side.

### With Flush Mounting Adaptor

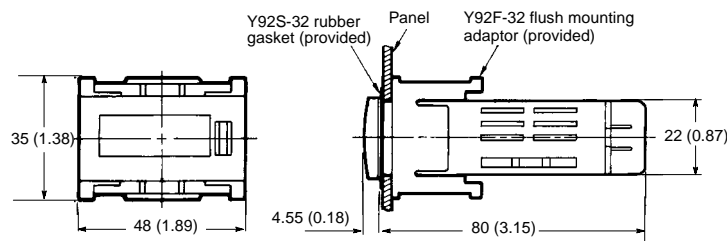
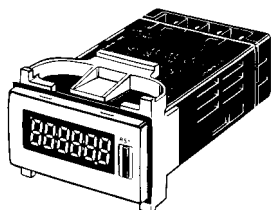

# Installation

## ■ TERMINAL ARRANGEMENT

### AC Models

#### H7GP-C

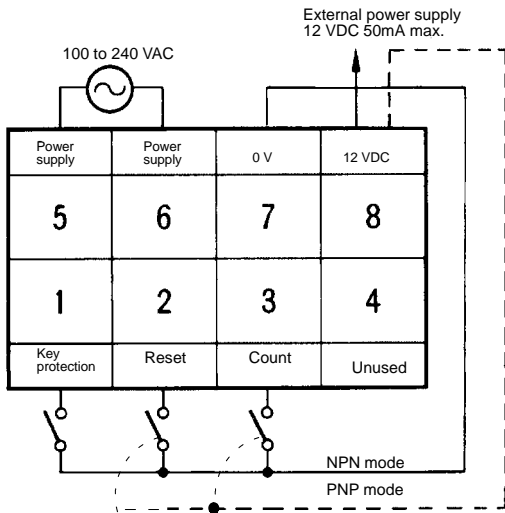

#### H7GP-T

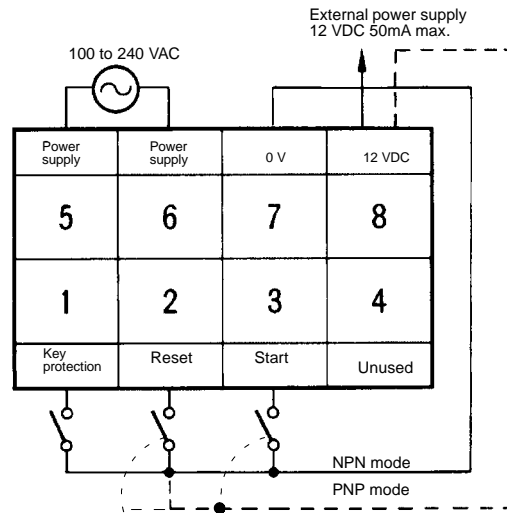

### DC Models

#### H7GP-CD

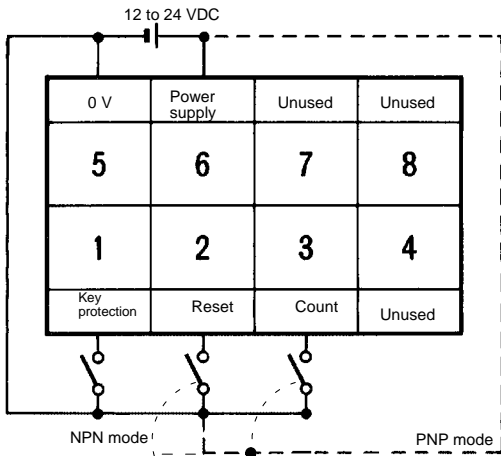

#### H7GP-TD

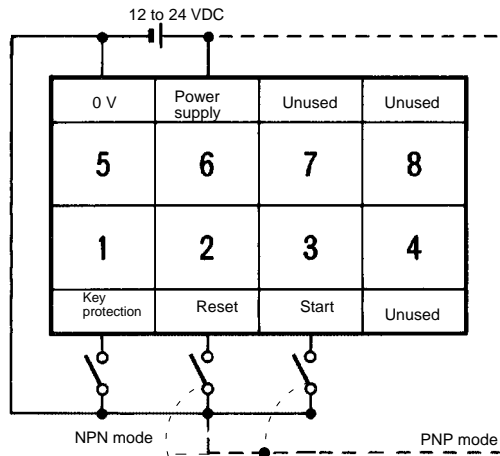

## INPUT CONNECTIONS

### No-voltage Input (NPN Input Mode)

#### Reset, Count 1, Count 2, and Count Inputs

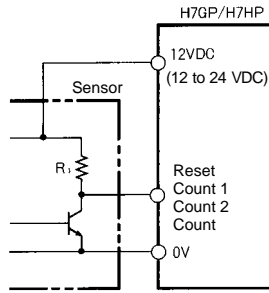

#### Reset, Count 1, Count 2, and Count Inputs Specification

Short-circuit (ON) impedance:	1 k $\Omega$ max.
Short-circuit (ON) residual voltage:	2 VDC max.
Current flow for 0- $\Omega$ short-circuit:	Approx. 2 mA
Open (OFF) impedance:	100 k $\Omega$ min.

### Key Protection Input

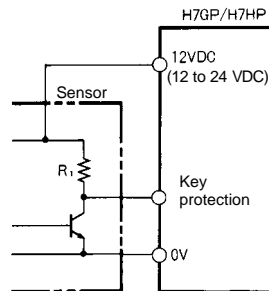

#### Key Protection Inputs Specification

Short-circuit (ON) impedance:	1 k $\Omega$ max.
Short-circuit (ON) residual voltage:	0.5 VDC max.
Current flow for 0- $\Omega$ short-circuit:	Approx. 0.5 mA
Open (OFF) impedance:	100 k $\Omega$ min.

### Voltage Input (PNP Input Mode)

#### Reset, Count 1, Count 2, and Count Inputs

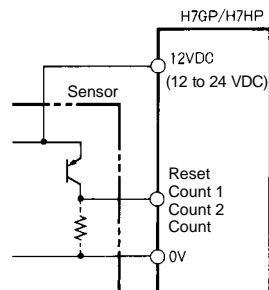

#### Reset, Count 1, Count 2, and Count Inputs Specification

Short-circuit (ON) impedance:	1 k $\Omega$ max.
ON voltage:	9 to 24 VDC
OFF voltage:	5 VDC max.
Open (OFF) impedance:	100 k $\Omega$ min.

## Precautions

### ■ POWER SUPPLIES

When turning the power ON and OFF, input signal reception is possible, unstable, or impossible as shown in the diagram below.

Apply the power supply voltage through a relay or switch in such a way that the voltage reaches a fixed value immediately.

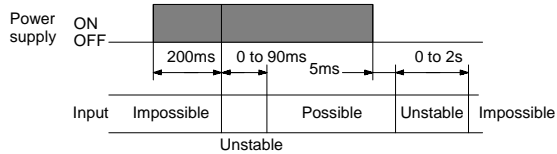

Although the H7GP power supply (primary side) is isolated from control circuits (secondary side) by a transformer, the primary and secondary sides of the transformer are linked by a capacitor, making it possible for high-frequency components to leak to the secondary side. Take precautions against electrical shock when the input circuits are connected to exposed parts.

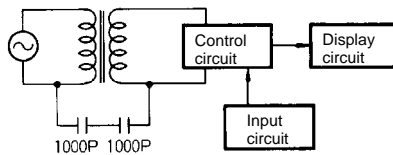

### ■ SELF-DIAGNOSTIC FUNCTION

The following displays will appear if an error occurs.

Display	Error	Correction
—	-99999 max.	Press RST Key or reset input
e1	CPU	Press RST Key or turn power OFF and then ON
e2	Memory	

### ■ PANEL MOUNTING

The panel surface is water-resistant (conforming to NEMA 4 (indoors) and IP66). In order to prevent the internal circuit from water penetration through the space between the counter and operating panel, secure the Y92S-32 rubber gasket between the counter and operating panel with the Y92F-32 panel mounting adapter.

### ■ OTHER

Water resistance may deteriorate depending on the environment. Periodically check water resistance.

Oil resistance is not applicable to all types of oil. Be sure to test any specific oils before actual application.

### ■ LABELS

There are labels included with the Counter for your convenience. These can be attached and used as necessary.

#### H7GP

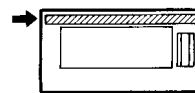

**NOTE: DIMENSIONS SHOWN ARE IN MILLIMETERS. To convert millimeters to inches divide by 25.4.**

# OMRON®

Omron Europe B.V. EMA-ISD, tel:+31 23 5681390, fax:+31 23 5681397, <http://www.eu.omron.com/ema>