

### Stable Detection Background-Suppression-Type

- Background influences are eliminated by a unique optical system for setting the detection distance
- Small black-/white-error
- Independant against ambient light
- Sensing distance mechanically adjustable:  
BGS setting distance: 150... 900 mm  
Detecting distance: 0 -750 mm
- Small housing-case specially designed for conveyer-application (only 8 mm of thickness on the top of the housing)
- Nearly no blind-zone by using additional receiver
- Easy BGS-adjustment by 6-turn-knob
- Sensitivity adjustment for near side detector
- Stability function indication by blinking LED
- Integrated jamming control unit (Only F3C-AA42-3J)
- Confirms to relevant EN/IEC standards, CE

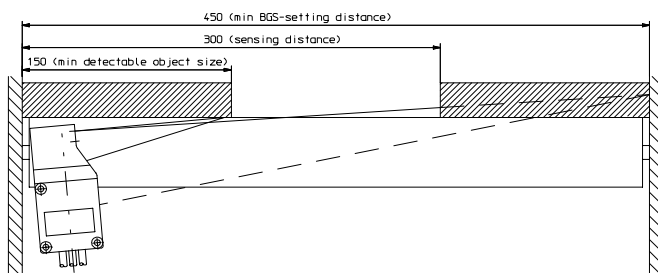

Example for sensing characteristics (detection area) in conveyer application and description of setting the minimum and maximum Background Suppression (BGS) function

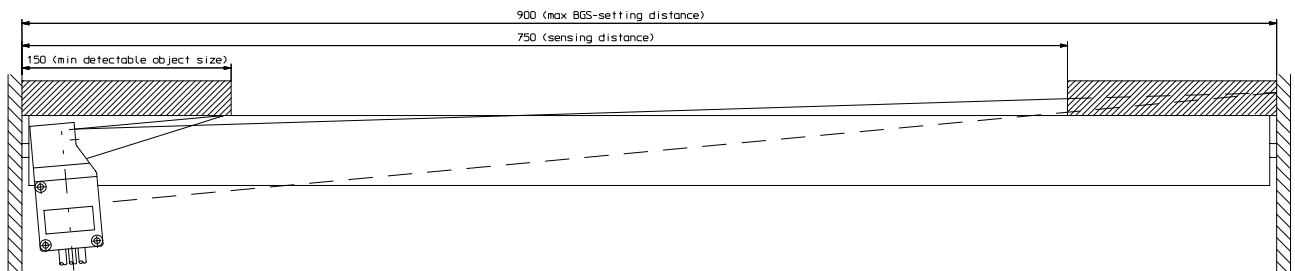

## Distance settable Photoelectric Sensor

F3C-AA42-1
F3C-AA42-3J

### Specifications

Item	F3C-AA42-1 / F3C-AA42-3J
LED for emitter	Infrared LED (wavelength 880 nm)
Sensitivity adjustment for BGS	6-turn endless adjustor
Sensitivity adjustment for near side detector	1-turn potentiometer
Typical adjustment range	0 ... 200 mm (Kod.-Gry./90 % refl.)
Connecting method/cable length	Prewired Power supply (M12 plug) / 30 cm (4 x 0,34 mm <sup>2</sup> ) Neighbg. sens. (M12 socket) / 150 cm (4 x 0,34 mm <sup>2</sup> ) Valve output (without socket) / 200 cm (2 x 0,35 mm <sup>2</sup> )
(Only F3C-AA42-3J)	
(Only F3C-AA42-3J)	
Output configuration	PNP
Control output	Dark-on Jamming control output/input via M12 moulded plug/socket, prewired valve control output
(Only F3C-AA42-3J)	
Circuit protection	Load short-circuit protection and mutual interference suppression
LED stability-/function indication	Permanent light = Object detected/stable function Blinking light = Object detected/instable function
Materials	Case: ABS plastic Lenses: Acrylic, PMMA
Weight	60g (F3C-AA42-1) / 180 g (F3C-AA42-3J)
Attachment	Screwdriver for adjustment, instruction manual

### Ratings/Characteristics

Item	F3C-AA42-1 / F3C-AA42-3J
Power supply voltage	10 to 30 VDC; ripple 10 % max.
Current consumption	40 mA max.
Settable distance for background suppression	150... 900 mm (Kod. -Gray-Cd., 90 % refl., 200 x 200 mm)
Detecting distance (recommended)	0 ... 750 mm (Kodak-Gray-Cd., 90 % refl., 200 x 200 mm)
Hysteresis	BGS-receiver: Max. 2 % of adjusted distance Energetic receiver: Max. 20 % of adjusted distance
Reflectivity (Black-/white-error)	max. 10 % of detection distance (Smax. 750 mm)
Spot size	40 mm diameter at 750 mm detection distance
Response time	max. 10 ms for both operation and release
Control/Valve output current (Only F3C-AA42-3J)	150 mA max. at 30 VDC (voltage drop max. 2,0V)
Jamming supply current (Only F3C-AA42-3J)	5 A max. at 30 VDC (max. 30 sensor may be connected for jamming control)
Ambient illumination	Incandescent lamp: Illumination on optical spot: max.5.000 lx Sunlight: Illumination on optical spot: max. 5.000 lx Fluorescent lamps: max. 5.000 lx
Ambient temperature	Operating: -5°C to +55°C (no icing)
Insulation resistance	20 MΩ min. (at 500 VDC)
Dielectric strength	1.000 VAC, 50/60 Hz for 1min.
Vibration resistance	10 ... 55 Hz, amplitude = +/-1,5 mm (or 300 m/s <sup>2</sup> ) for 2 hrs. each in X, Y and Z-direction
Shock resistance	Pulse shape: half-sine, peak acceleration: 300 m /s <sup>2</sup> , duration of pulse: 18 ms
Enclosure rating	IP 54

## Engineering Data

F3C- Spotdiameter via detection distance

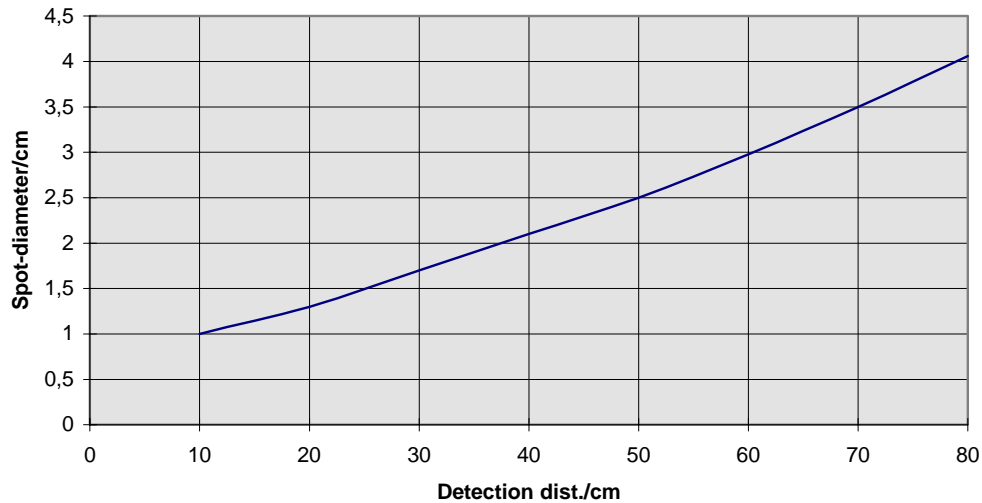

Operating range ( Sn = 20 cm / 45 cm / 60 cm / 75 cm)

F3C - Operating characteristics

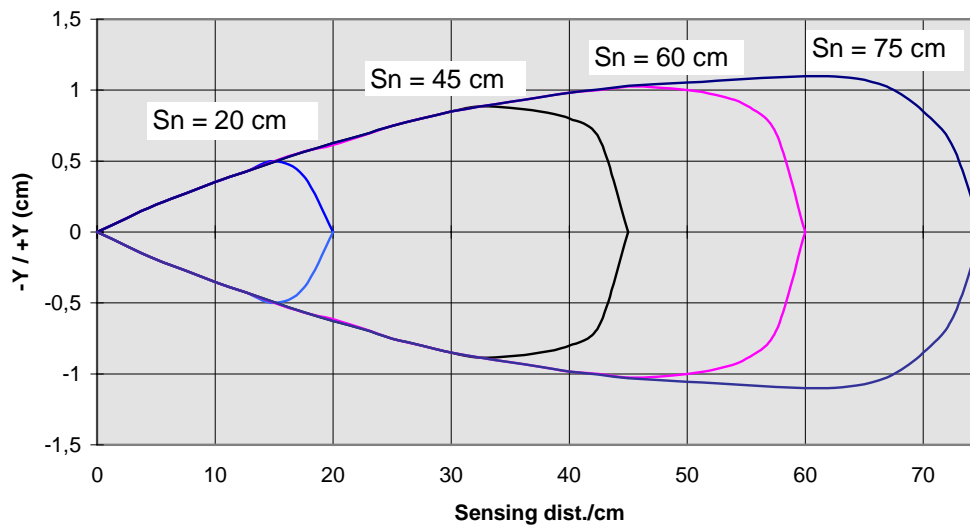

Reflecting object: Kodak-Gray-Card / 90 % reflectivity / 200 mm x 200 mm

## Angle characteristics of F3C-BGS-Conveyor Sensor

### 1. Vertical detection

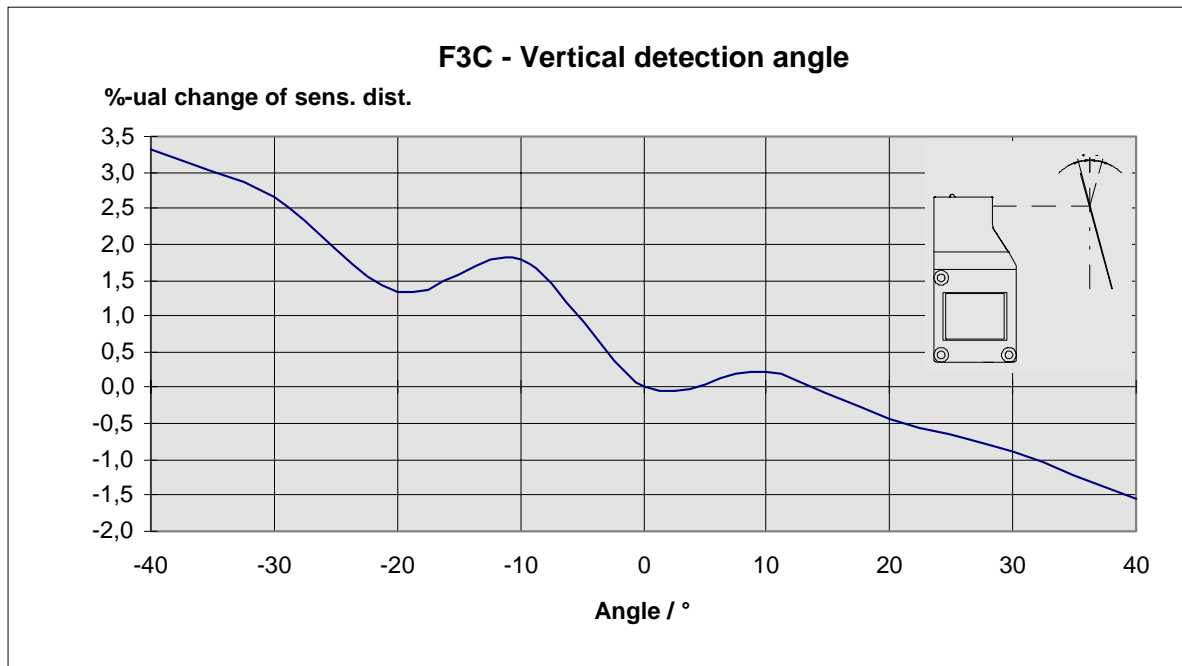

### 2. Horizontal detection

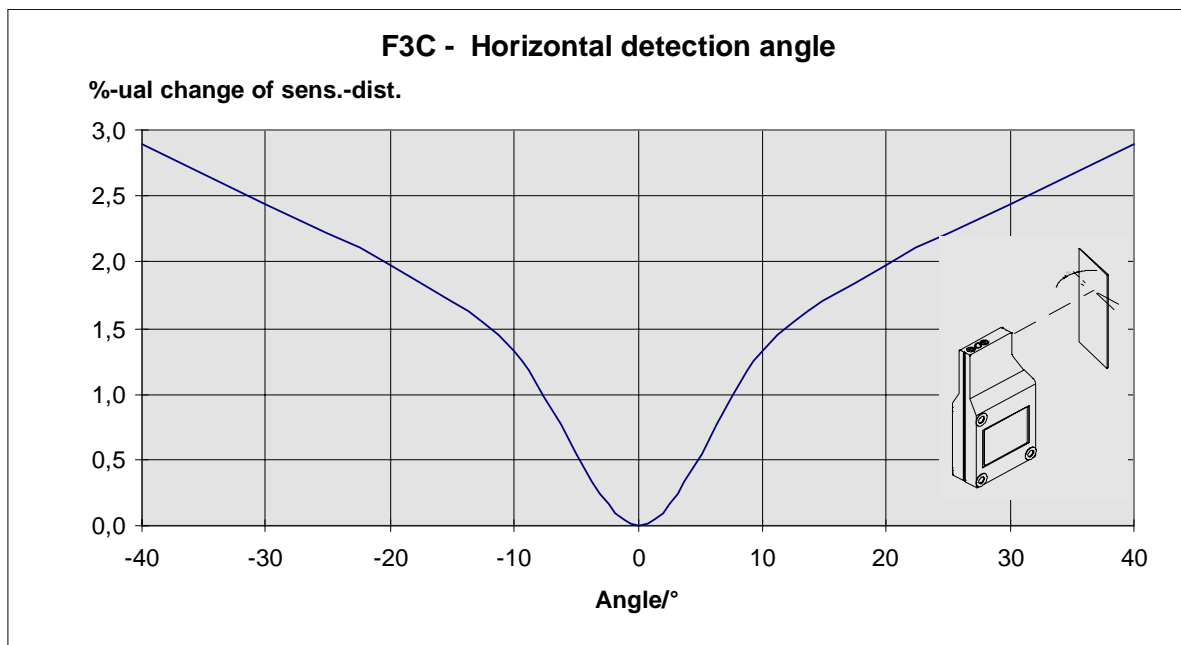

Reflecting object: Kodak-Gray-Card / 90 % reflectivity / 200 mm x 200 mm

### Black-/White-Error

B/W-Error related to Kod.-Gray-Cd. 90 %

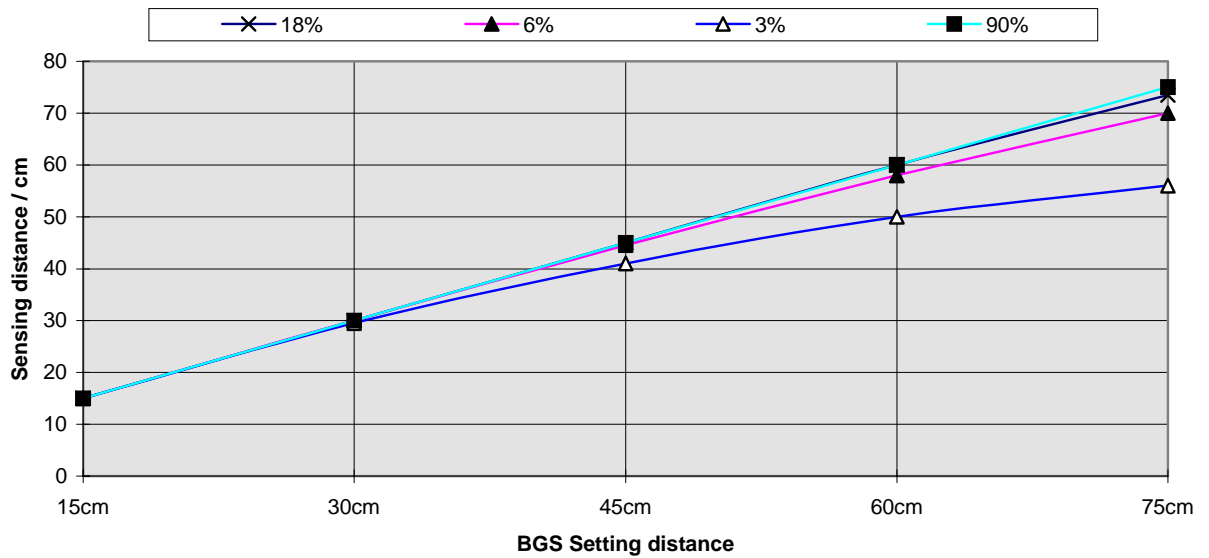

### Nomenclature

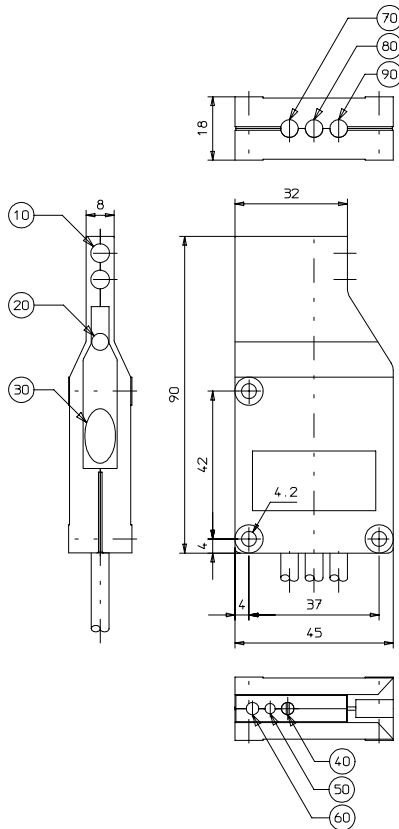

Pos.	Functional description
10	IR-emitting LED
20	Near-side detector
30	Optical module
40	Black coloured adjustment knob for setting distance (6-turns)
50	LED light-/stability indicator
60	Yellow knob for near-side adjustment (1-turn)
70	M12-plug for power supply
80	M12-socket for neighbouring sensor (Only 3J-type)
90	Valve cable (Only 3J-type)

### Operation

Output configuration	Mode switch	Output transistor	Output circuit	
			F3C-AA42-1	F3C-AA42-3J
PNP	Dark-ON	ON when light is not received		

### Timing chart

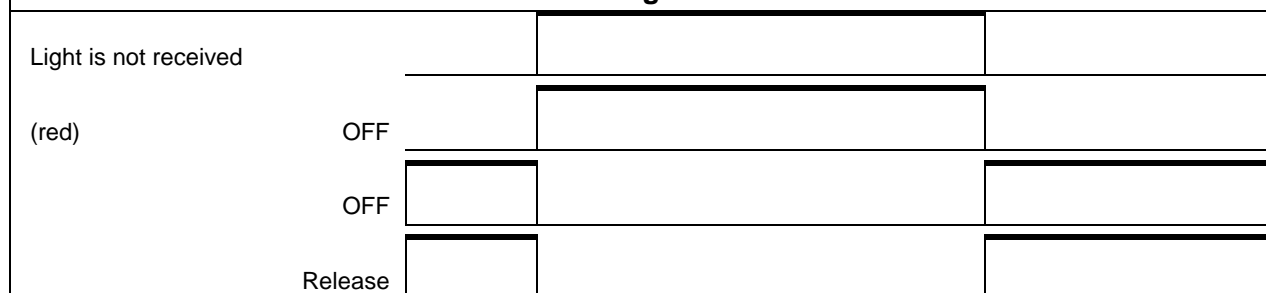

### • Jamming control connections and principal circuit (Only F3C-AA42-3J)

F3C-AA42-3J	Plug for power supply	Socket for neighbouring sensor	Cable for valve
No. 1/bn	+ Vcc (10 ... 30 V/DC)	+ Vcc (10 ... 30 V/DC)	- / -
No. 2/wt	Control output	Control Input	- / -
No. 3/bl	0 V	0 V	- / -
No. 4/bk	Release Input	Release Output	- / -
bn (bk)	- / -	- / -	+ Valve output
bl (bk-ye)	- / -	- / -	0V/Valve

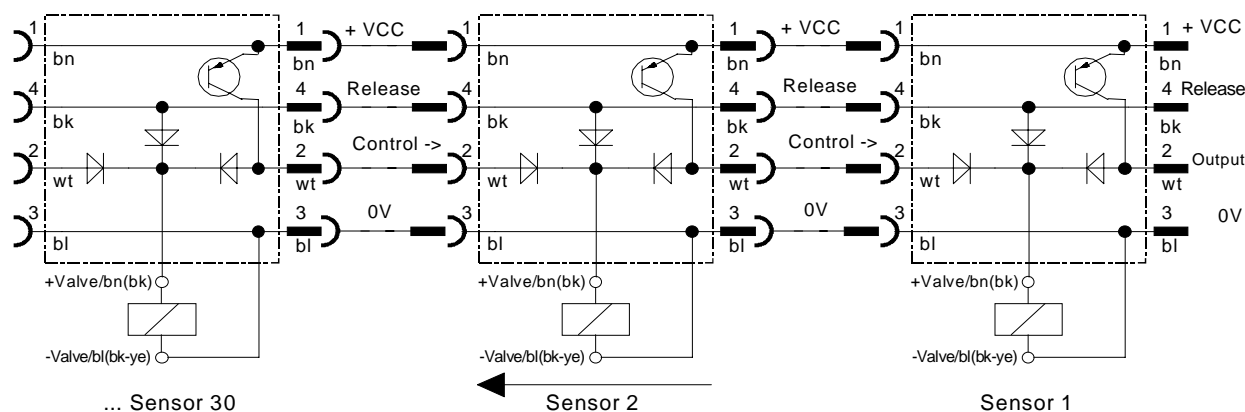

### • Installation and adjustment

1. Switch off power supply
2. Connect sensor 1 to the power supply station. Make sure that the correct voltage value is adjusted. Max. 30 sensors can be connected together. The power supply is linked from one switch to the other via M12-connector.
3. Fix sensor, by using an adequate mounting bracket, in the middle of between the conveyer rolls and twist the case slightly backward (2-5°)
4. Turn black-coloured distance adjustment knob (Pos. 40) and yellow coloured screw (Pos. 60) for near-side-detection carefully counterclockwise until minimum position is reached
5. Switch on power supply
6. At first adjust the sensing distance by turning the black knob, that at least 5 % of the switching distance value can be guaranteed related to the reflecting background (check by using a Kodak Gray Card with 90 % reflectivity)
7. Activate near-side detector by turning the yellow-coloured knob (Pos. 60) clockwise - the red LED should not blink and should light permanently when the object is detected. Otherwise increase sensitivity by turning the yellow knob clockwise
8. When object is removed, the red LED should not light or blink

### Recommended adjustment

The adjusted sensing-distance of the near-side detector should not exceed the BGS-Setting-distance.

### Correct operation

The moving direction of the sensor or object should be preferably along the optical axis of the light beam. Lateral approach is also possible. Movement from the top to the bottom or opposite can cause malfunction and should be avoided.

In case of installing two sensors facing each other, the optical axis should be moved to prevent any mutual interference.

Avoid influences of any strong ambient light sources that can decrease the sensitivity of the sensor or cause instable working condition.

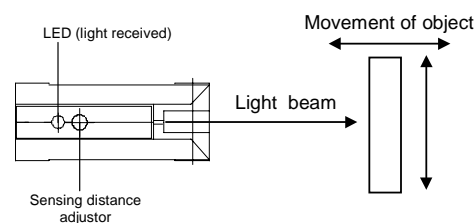

### Connections and precautions

If the input/output lines of the photoelectric sensor are placed in the same conduit or duct as power lines or high-voltage lines, the photoelectric sensor could be induced to malfunction, or even be damaged by electrical noise. Either separate the wiring or use shielded lines as input/output lines to the photoelectric sensor.

The cord connected to the Sensor can be extended up to 50 m provided that the diameter of each wire is 0,3 mm<sup>2</sup> minimum.

## Distance settable Photoelectric Sensor

F3C-AA42-1
F3C-AA42-3J

### Maintenance

Normally the F3C doesn't need any maintenance. Only the optical surfaces should be cleaned from time to time by using a soft cloth.

### Startup Operation

A maximum of 300 ms is required from the time power is turned on until F3C is able to detect objects. If power is supplied to the loads and the F3C from different sources, turn on power to the F3C first.

### Water resistivity

Do not use F3C in water, in rain or outdoors.

### Accessories

Standard mounting bracket for easy installation.  
Ordering number E39-L40

