

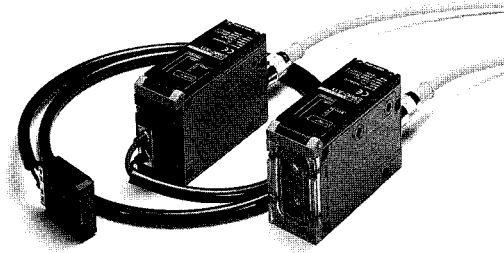

RGB Color Sensor Discriminates Delicate Differences in Color. Best Color Sensor in the Industry.

- Built-in LED light source ensures long service life and maintenance-free operation.
- Discriminates differences in color without being influenced by changes in ambient temperature, brightness of sensing objects, or positioning of sensing objects.
- Models with built-in amplifiers for long-distance sensing and those with fiber heads for tiny spot sensing are available.
- Incorporates easy-to-see detection level and threshold level indicators.
- Degree of protection to IP66 and easy to maintain.
- 4-color registration/4-output models are also available.



Ordering Information

■ RGB Color Sensor

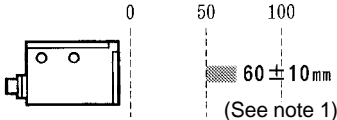
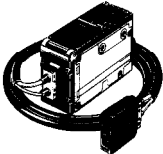
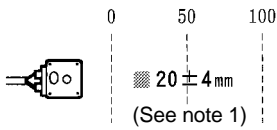
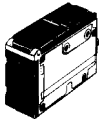
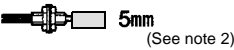
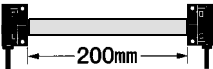
Type	Model	Appearance	Sensing distance	Spot diameter	No. of outputs	Output
Built-in Amplifier Type	E3MC-A11		 $60 \pm 10 \text{ mm}$ (See note 1)	12 mm	1	NPN
	E3MC-A41				PNP	
	E3MC-MA11				4	NPN
	E3MC-MA41				PNP	
Optical Fiber Type	E3MC-X11	 The shape of the amplifier section is the same as for the E3MC-(M)Aj j .	 $20 \pm 4 \text{ mm}$ (See note 1)	3 mm	1	NPN
	E3MC-X41				PNP	
	E3MC-MX11				4	NPN
	E3MC-MX41				PNP	
General-purpose Optical Fiber Type	E3MC-Y11		Standard sensing distance E32-CC200  5 mm (See note 2)	Varies with the recommended fiber.	1	NPN
	E3MC-Y41				PNP	
	E3MC-MY11				4	NPN
	E3MC-MY41				PNP	
			E32-T16 			

Note: 1. Refer to *Specifications* on page 3.

2. Eleven colors are discriminated at this distance. For a typical example, nine colors are discriminated at a sensing distance of 12 mm. Refer to page 6 for the definition of sensing distance.

■ Accessories (Ordering Separately)

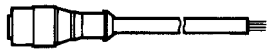
Name	Sensor I/O Connector	
Use	A replacement or cord extension for a total of 5 m.	
Model	E39-C1 2M (2 m) (Included)	E39-C1 5M (5 m) (Separately sold)
Appearance		

Name	Sensor Mounting Bracket	DIN-track Mounting Bracket
Use	When mounting the E3MC. (Can be inclined to 15_)	When mounting to the DIN track.
Model	E39-L114	E39-L115

Application Examples

Detection of internal yellow resin plates of battery



Pattern positioning

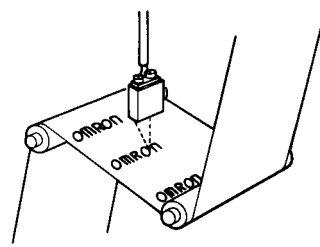

Discrimination of front and back sides of objects

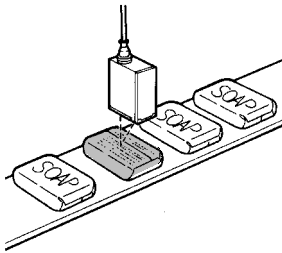

Discrimination of the color order of tissue paper boxes

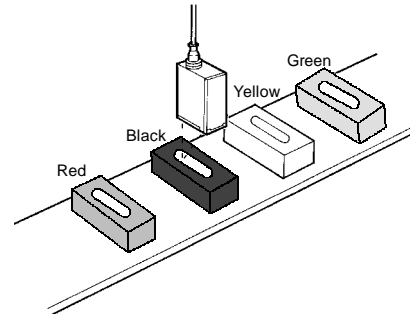

Item	Built-in amplifier type	Optical fiber type	General-purpose optical fiber type
	E3MC-Aj 1, E3MC-MAj 1	E3MC-Xj 1, E3MC-MXj 1	E3MC-Yj 1, E3MC-MYj 1
Discriminating color selection (1-output model only)	4 banks selectable (either by bank selection input or by using the SELECT button) Input response time for bank selection: 50 ms max.		
Indicator	Operation indicator (orange LED), 4-level bank indicator (green LED, see note 2), 7-level threshold indicator (red LED), 8-level detection indicator (green LED), and four channel indicators (orange LED, see note 3)		
Protection	Protection from reversed power supply connection and output short-circuit		
Ambient illumination	Incandescent lamp: Illumination on optical spot: 3,000 lx max. Sunlight: Illumination on optical spot: 10,000 lx max.		
Ambient temperature	Operating: -25°C to 55°C (with no icing)		
Ambient humidity	Operating: 35% to 85% (with no condensation)		
Permissible fiber bending radius	---	10 mm min.	Varies with the type of recommended fiber
Insulation resistance	20 MΩ min. (at 500 VDC)		
Dielectric strength	1,000 VAC, 50/60 Hz for 1 min		
Vibration resistance	Destruction: 10 to 55 Hz, 1.0-mm double amplitude or 150 m/s ² (approx. 15G) for 2 hrs each in X, Y, and Z directions (see note 4)		
Shock resistance	Destruction: 500 m/s ² (approx. 50G) for 3 times each in X, Y, and Z directions (see note 5)		
Degree of protection	IEC IP66 (with protective cover in place)		
Material	Case: Zinc die-cast Cover: PES	Case: Zinc die-cast Cover: PES Fiber head: ABS	Case: Zinc die-cast Cover: PES
Weight (with 2-m cord)	Approx. 350 g	Approx. 400 g	Approx. 350 g

Note: 1. **Definition of Sensing Distance**
Refer to the following table and the diagram to the right.

Item	E3MC-(M)Aj j	E3MC-(M)Xj j
Color discrimination mode	Mode C	
Response time	Standard mode	
Tolerance (θ)	15°	10°
Detectable colors	11 standard colors	

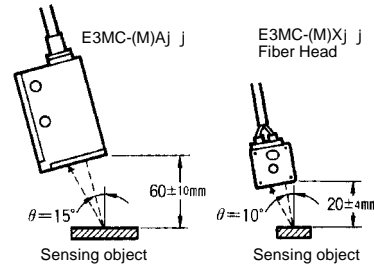

- 1-output models only: E3MC-Aj j /-Xj j /-Yj j
- 4-output models only: E3MC-MAj j /-MXj j /-MYj j
- 0.75-mm double amplitude or 100 m/s² (10G) when using a Mounting Bracket.
- 300 m/s² (30G) when using a Mounting Bracket.

Standard Sensing Objects

Color (11 standard colors)	Munsell color notation
White	N9.5
Red	4R 4.5/12.0
Yellow/red	4YR 6.0/11.5
Yellow	5Y 8.5/11.0
Yellow/green	3GY 6.5/10.0
Green	3G 6.5/9.0
Blue/green	5BG 4.5/10.0
Blue	3PB 5.0/10.0
Blue/purple	9PB 5.0/10.0
Purple	7P 5.0/10.0
Red/purple	6RP 4.5/12.5

Engineering Data

Sensing Distance vs. Color Differences (Typical)

E3MC-(M)Aj j

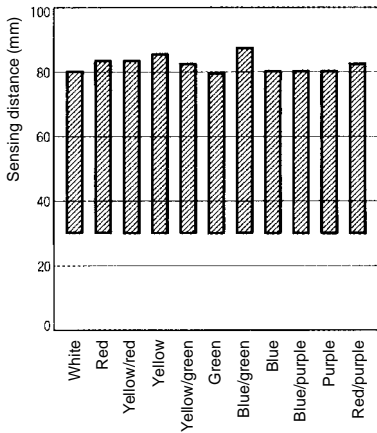

Angle Characteristics (Typical)

E3MC-(M)Aj j (X Direction)

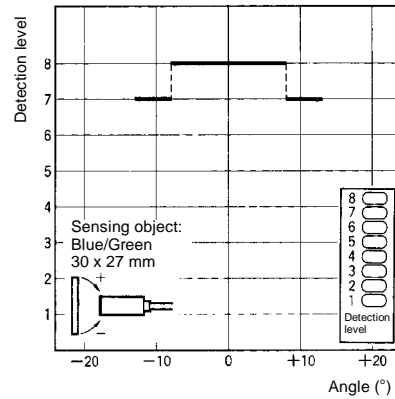

Angle Characteristics (When Teaching at an Inclination of 15_)

E3MC-(M)Aj j (Y Direction)

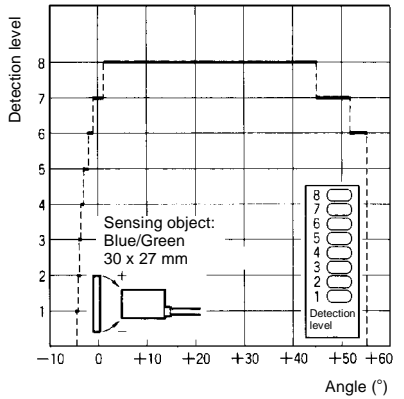

Sensing Distance vs. Color Differences (Typical)

E3MC-(M)Xj j

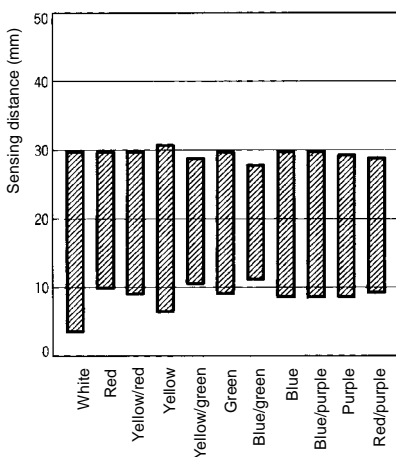

Angle Characteristics (Typical)

E3MC-(M)Xj j (X Direction)

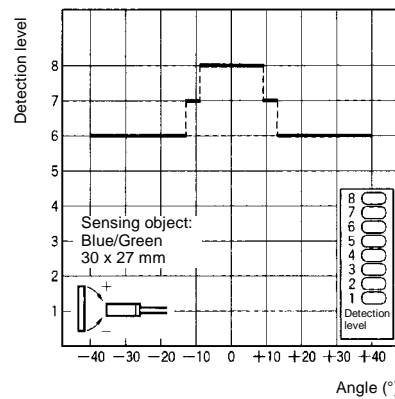

Angle Characteristics (When Teaching at an Inclination of 10_)

E3MC-(M)Xj j (Y Direction)

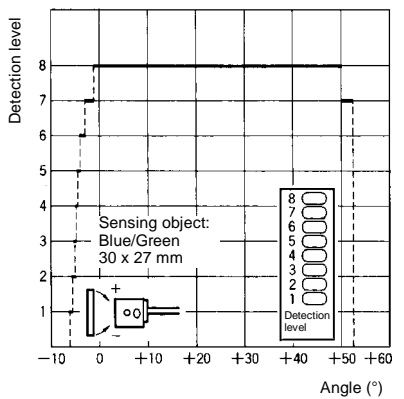

■ General-purpose Optical Fiber Type

Recommended Fiber: Reflective Optical Fiber

The following optical fibers are recommended for use with the E3MC-(M)Yj j .

Model	Sensing distance (see note 1)
E32-DC200	5 mm
E32-CC200 (see note 2)	5 mm
E32-D32L (see note 3)	4.5 mm
E32-D11L	5 mm

- Note:**
1. The E3MC-(M)Yj j discriminates eleven colors at the above distances. For a typical example, nine colors are discriminated at a sensing distance of 12 mm.
 2. The fiber to be inserted into the emitter is indicated with white lines. Insert the amplifier fiber into the lower emitter section.
 3. The fiber to be inserted into the emitter is indicated with dotted yellow lines. Insert the amplifier fiber into the lower emitter section.

Definition of Sensing Distance of a Reflective Fiber

The sensing distance of reflective fiber is the sensing distance of the Sensor located obliquely to the sensing object as shown in the following illustration.

Set to C mode and standard mode (response time), and threshold set to the standard level with an inclination angle of 20 degrees ($\theta=20^\circ$).

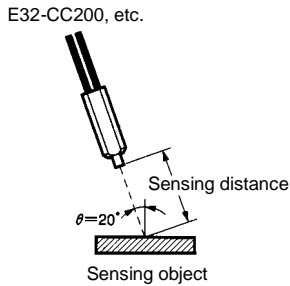

Recommended Fiber: Through-beam Fiber

The following optical fibers are recommended for use with the E3MC-(M)Yj j .

Model	Sensing distance (see note)
E32-TC200	30 mm
E32-T11L	60 mm
E32-T16	200 mm
E32-T17L	1.1 m

Note: The E3MC-(M)Yj j discriminates red, blue, and yellow films in stable operation at the above distances.

Operating Range Characteristics (Typical)

E32-DC200

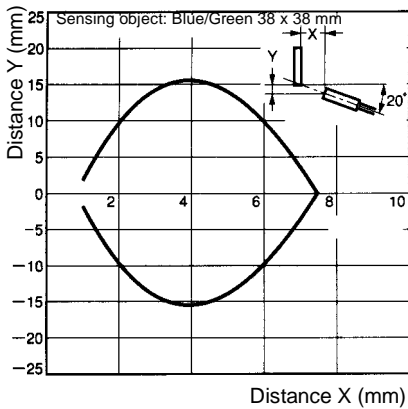

E32-CC200

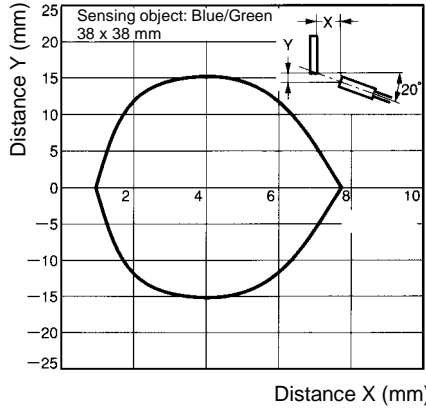

E32-D32L

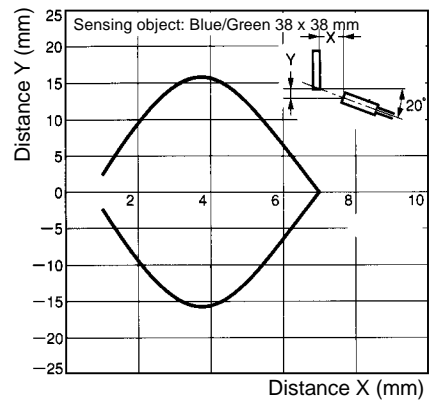

E32-D11L

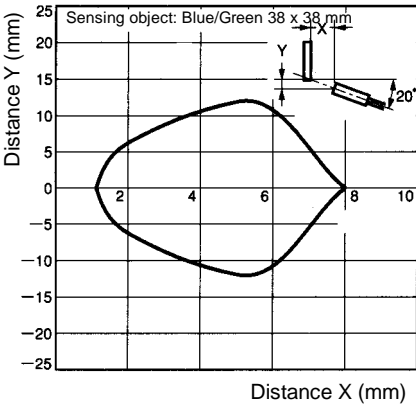

Sensing Objects: Red, Blue, and Yellow Films

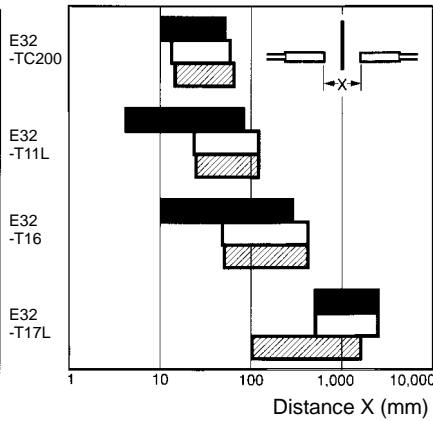

- Sensing object: Film in red (rosco/UX, scarlet)
- Sensing object: Film in Yellow (rosco/UX, straw)
- Sensing object: Film in Blue (rosco/UX, skyblue)

The above color films are made by the rosco company.

Chromatic Sensitivity (Typical)

Sensing Object: Bottle E32-T17L

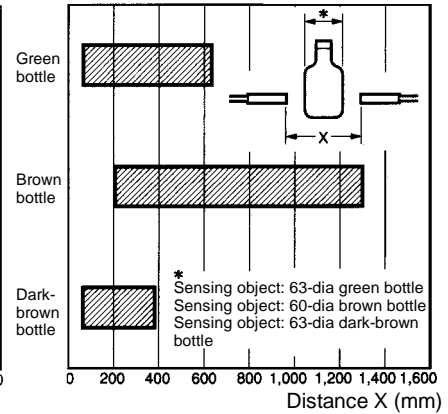

- * Sensing object: 63-dia green bottle
- Sensing object: 60-dia brown bottle
- Sensing object: 63-dia dark-brown bottle

Available Optical Fibers

In addition to the previous recommended optical fibers, the following optical fibers are available for the E3MC-(M)Yj j . Refer to the *E3X-NH Datasheet (E258-E1)* for the following optical fibers in detail. Optical fibers other than the following are not available.

Model	Sensing method	Remarks
E32-TC200A	Through-beam	Not different from the E32-TC200 in optical characteristics.
E32-TC200B		
E32-TC200C		
E32-TC200D		
E32-T12L		Not different from the E32-T11L in optical characteristics.
E32-T14		---
E32-T11	---	
E32-T11R	Through-beam (R1 fiber)	---

Model	Sensing method	Remarks
E32-DC200B	Reflective	Not different from the E32-DC200 in optical characteristics.
E32-DC200C		
E32-DC200D		
E32-D12		
E32-D11	---	
E32-D11R	Through-beam (R1 fiber)	---
E32-G14	Groove	---

Nomenclature

- E3MC-Aj j (1-output Models)**
- E3MC-Xj j (1-output Models)**
- E3MC-Yj j (1-output Models)**

Operation Indicator (Orange)
lit when output is ON.
Under mode B, the indicator will be lit when mode B is started or when the mode selector is set to TEACH.

Bank Indicator (Green)
Displays selected bank.

TEACH Button
Registers discriminating color.

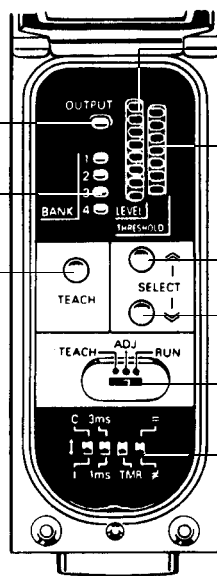

Detection Level Indicator (Green)
Displays similarity level between registered and detectable colors.

Threshold Indicator (Red)
Displays threshold level.

SELECT UP Button, SELECT DOWN Button
Bank selection
Threshold adjustment

Mode Selector
Selects TEACH, ADJ, or RUN mode.

Function Switch*
Color discrimination mode selection
Response time selection
OFF-delay timer setting
Conformity/Non-conformity output selection

- E3MC-MAj j (4-output Models)**
- E3MC-MXj j (4-output Models)**
- E3MC-MYj j (4-output Models)**

Operation Indicator (Orange)
lit when output is ON.

Channel Indicator (Orange)
Displays selected channels.
lit when the output of each channel is ON.

TEACH Button
Registers discriminating color.
Used to check the number of channels that are indicated by both the operation indicator and channel indicator.

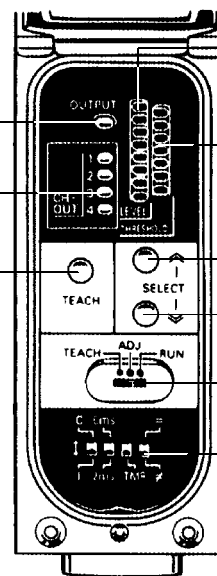

Detection Level Indicator (Green)
Displays similarity level between registered and detectable colors.

Threshold Indicator (Red)
Displays threshold level.

SELECT UP Button, SELECT DOWN Button
Channel selection
Threshold adjustment

Mode Selector
Selects TEACH, ADJ, or RUN mode.

Function Switch*
Color discrimination mode selection
Response time selection
OFF-delay timer setting
Conformity/Non-conformity output selection

***Function Switch**

The following settings are possible in RUN or ADJ mode. In case of 4-output models, all channels are subject to the selection of the following settings. Each pin of the function switch is factory-set to the upper position.

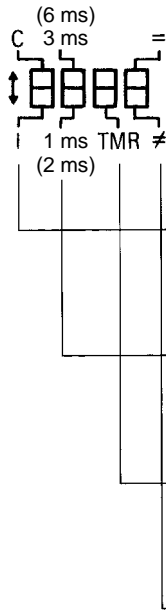

Note: Figures in parentheses are for the 4-output models.

Color Discrimination Mode Selection (Mode C is Recommended for Normal Applications)

- Mode C: Color discrimination is performed according to R (red), G (green), and B (blue) ratio of the reflection light even if the sensing objects fluctuate up and down within the rated sensing range.
- Mode I: Color discrimination is performed according to RGB light intensity of reflection light. This mode ensures more delicate color discrimination than mode C.

Response Time Selection (Note: Figures in parentheses are for the 4-output models.)

- 3 ms (6 ms): The E3MC can stably detect minute differences of color. Set the response time to 3 ms for usual applications.
- 1 ms (2 ms): The E3MC will be in quick-response operation. Set the response time to 1 ms if high-speed response is required.

OFF-delay Timer Setting

- : No OFF-delay timer is set.
- TMR: A 40-ms OFF-delay timer is set for control output.

Conformity/Non-conformity Output

- =: Output is ON when the detected color coincides with the registered color.
- ≠: Output is ON when the detected color does not coincide with the registered color.

Note: Each pin of the function switch is factory-set to the upper position.

Operation

■ Output Circuits

E3MC-j 11 with NPN Output (1-output Models)

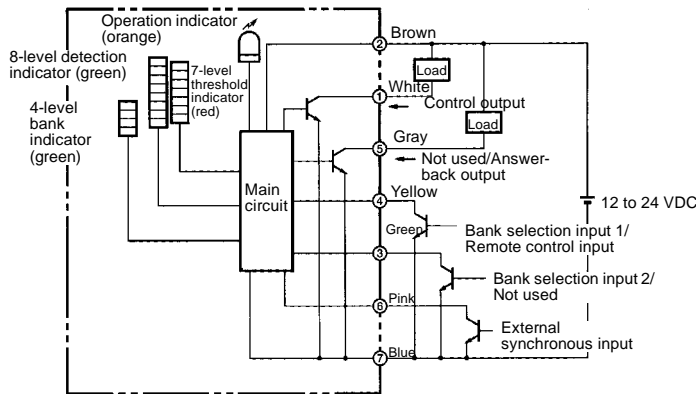

E3MC-Mj 11 with NPN Output (4-output Models)

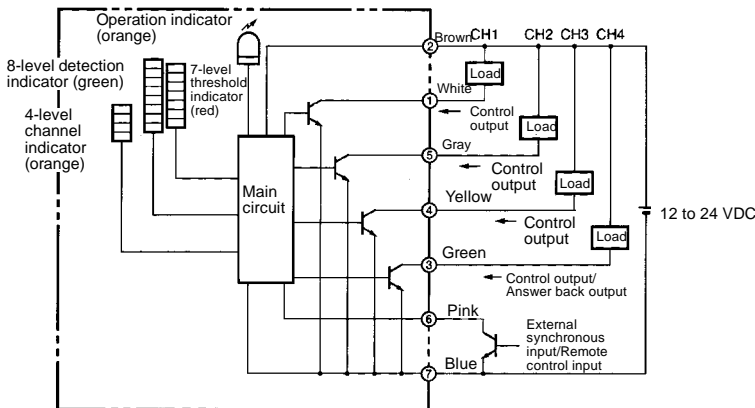

Connector Pin Arrangement

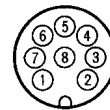

Note: Pin 8 is not used.

E3MC-j 41 with PNP Output (1-output Models)

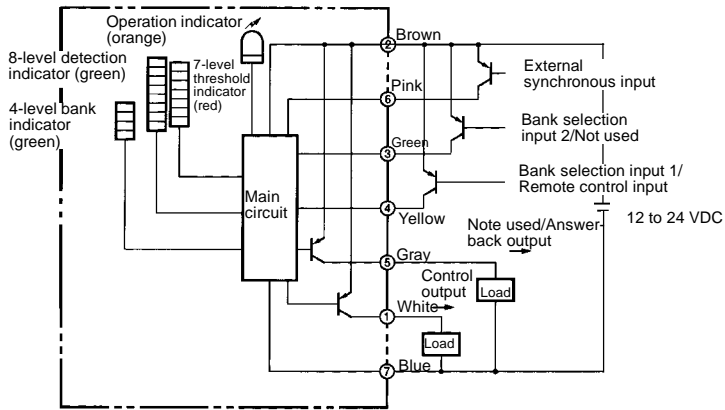

E3MC-Mj 41 with PNP Output (4-output Models)

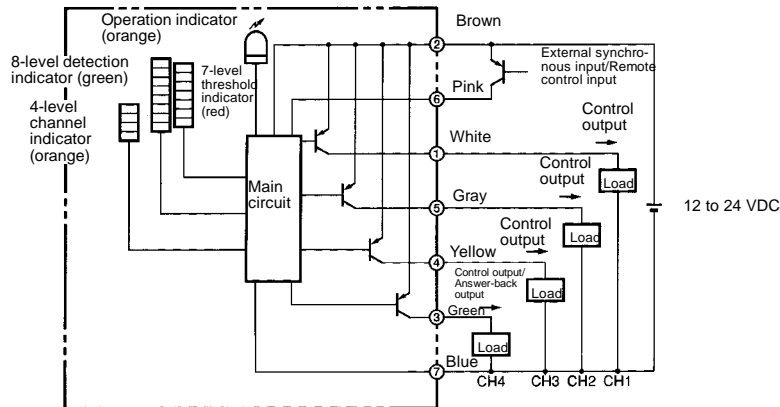

■ Settings

1-output Models (E3MC-Aj j /E3MC-Xj j /E3MC-Yj j)

1. Bank Selection

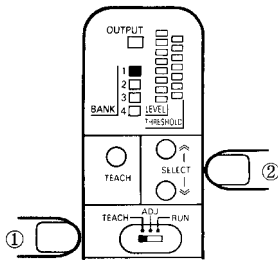

Set the Mode Selector to the TEACH mode and then select the BANK using the SELECT button.

2. Color Registration

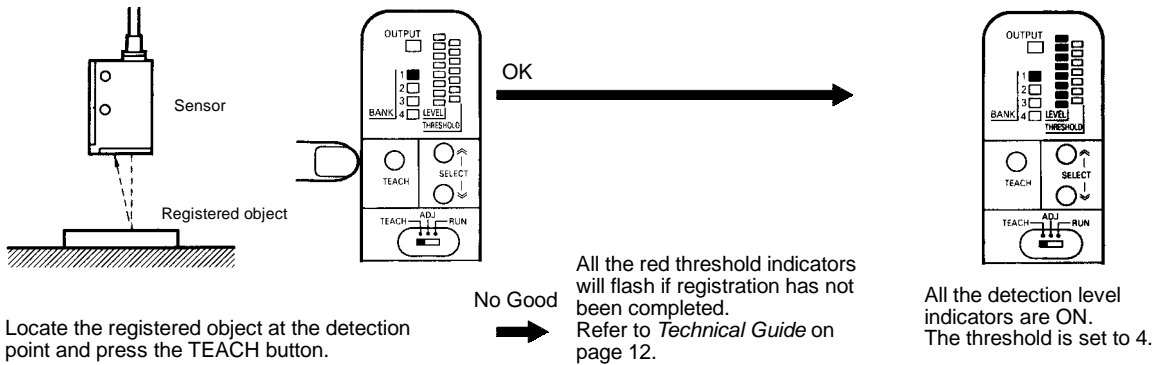

3. Threshold Adjustment (If Required)

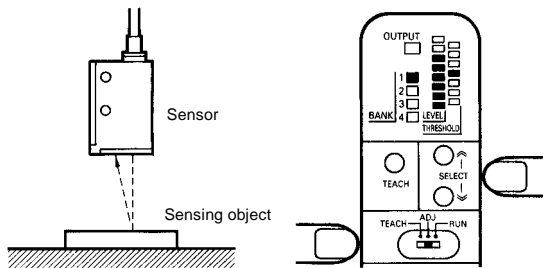

Press the SELECT button in ADJ mode with or without the sensing object located at the detection point. The bank selected in the TEACH mode or RUN mode will become the bank for the ADJ mode.

Detection Level and Tolerance

As the detected color becomes closer to the registered color, the number of lit detection level indicators increase. The control output of the E3MC will be ON if the detection level exceeds the threshold level and OFF if the detection level does not exceed the threshold level provided that the E3MC is in conformity output mode.

Set the threshold to a higher level for highly-precise color discrimination and to a lower level to ignore minor tint differences or dirt retention.

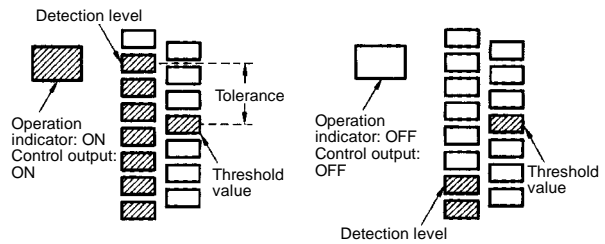

4. Operation

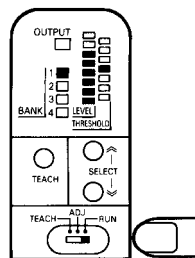

The detection operation is performed in RUN mode. The registered color is selected with bank selection input.

4-output Models (E3MC-MAj j /E3MC-MXj j /E3MC-MYj j)

1. Channel Selection

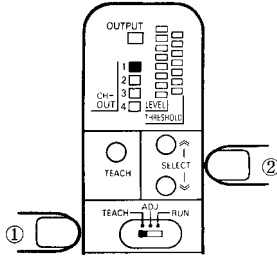

Set the Mode Selector to the TEACH mode and then select the channel using the SELECT button.

2. Color Registration

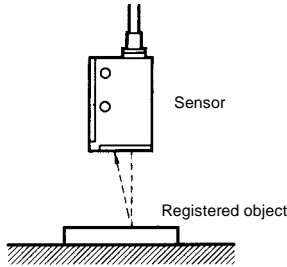

Locate the registered object at the detection point and press the TEACH button.

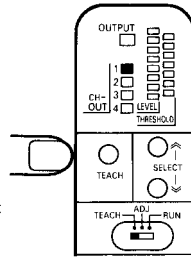

No Good



All the red threshold indicators will flash if registration has not been completed. Refer to *Technical Guide* on page 12.

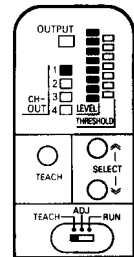

All the detection level indicators are ON. The threshold is set to 4.

3. Threshold Adjustment (If Required)

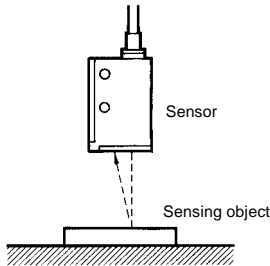

Press the SELECT button in ADJ mode with or without the sensing object located at the detection point. The channel selected in the TEACH mode or RUN mode will become the channel for the ADJ mode.

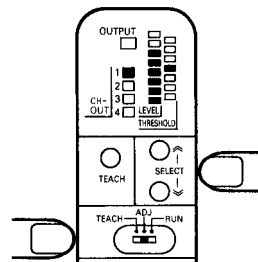

Detection Level and Tolerance

As the detected color becomes closer to the registered color, the number of lit detection level indicators increase. The control output of the E3MC will be ON if the detection level exceeds the threshold level and OFF if the detection level does not exceed the threshold level provided that the E3MC is in conformity output mode.

Set the threshold to a higher level for highly-precise color discrimination and to a lower level to ignore minor tint differences or dirt retention.

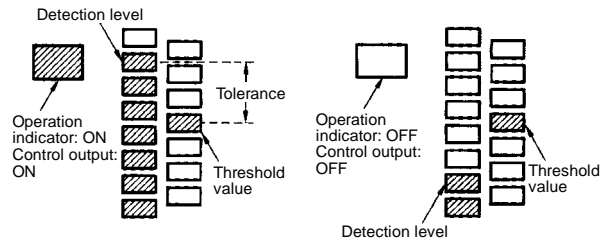

4. Operation

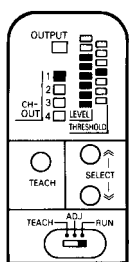

For indicating detection level and threshold value for other channels

Press the SELECT button.

For checking which channel is indicated with the operation indicator.

Press the TEACH button.

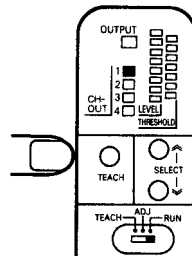

Displays the channel whose detection level is currently indicated in the channel indicator for three seconds.

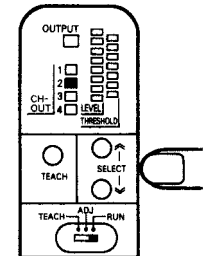

Displays the selected channel in the channel indicator for three seconds and indicates detection level and threshold value of the selected channel.

The detection operation is performed in RUN mode. ON/OFF status of each channel is displayed on the channel indicators. Doubly displayed channels (operation indicator and channel indicator) can be checked and selected by pressing the TEACH button and selected by pressing the SELECT button.

■ Detection Level and Indicator

Indicator								
Detection level	1	2	3	4	5	6	7	8

■ Technical Guide

Detection of Metal or Glossy Objects

If the E3MC does not detect metal or glossy objects accurately, change the mounting angle of the E3MC so that it will not receive regular reflection light directly reflected from the objects.

The mounting angle of the E3MC-(M)Xj j can be adjusted to approximately 10° with the mounting holes.

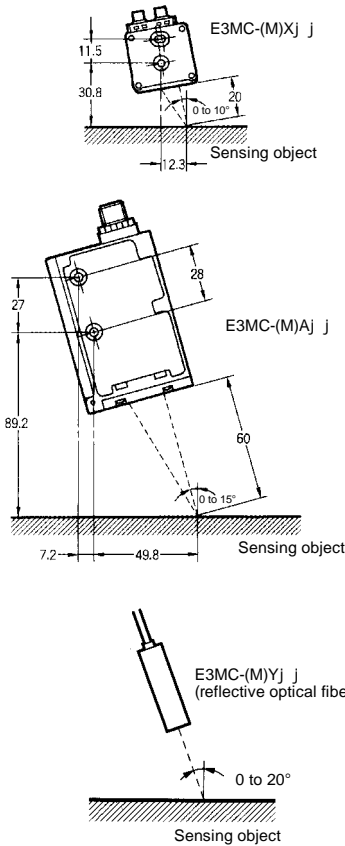

On the other hand, sensing objects such as metal or transparent plastic cases may be detected by allowing regular reflection.

Detection of White, Gray, or Black Objects

When registering white, gray, or black objects, change the color discrimination mode to "Mode I" to achieve a more stable color discrimination.

External Light

The E3MC may malfunction if it directly receives external light interference. Provide a cover to shut-out such external light interference.

Adjustment of Sensing Distance of General-purpose Optical Fiber Type

Unlike the E3MC-A or E3MC-X, the E3MC-Y may require adjustment of its sensing distance depending on the reflection rate. This also applies to the thru-beam type.

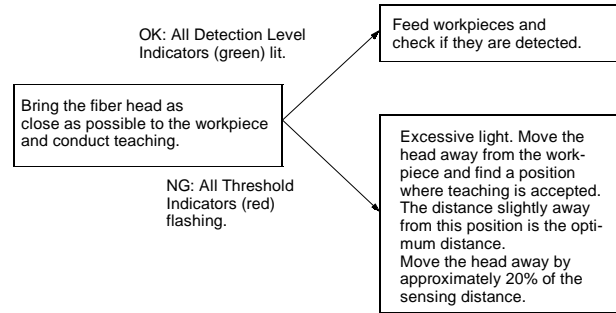

■ Registered Color Selection (Bank Selection Input)

1-output Models Only

The E3MC in RUN mode allows bank selection with external bank selection input 1 (yellow) and input 2 (green). The selected bank is indicated with the bank selection indicator.

NPN (E3MC-A11/-X11/-Y11)

Bank	Input 1	Input 2
1	OPEN	OPEN
2	GND	OPEN
3	OPEN	GND
4	GND	GND

PNP (E3MC-A41/-X41/-Y41)

Bank	Input 1	Input 2
1	OPEN	OPEN
2	Vcc	OPEN
3	OPEN	Vcc
4	Vcc	Vcc

External Synchronous Input Function

The measurement results will be directly output to the control output if the input from the external synchronous input terminal (pink) is set to OFF. The output will hold the previous status if the input of the external synchronous input terminal is set to ON. External synchronous input is valid in RUN or ADJ mode. As for the 4-output models, this function applies to the output of all the channels.

Condition	NPN (E3MC-j 11)	PNP (E3MC-j 41)
ON (Status on hold)	GND	Vcc
OFF (Result output)	OPEN	OPEN

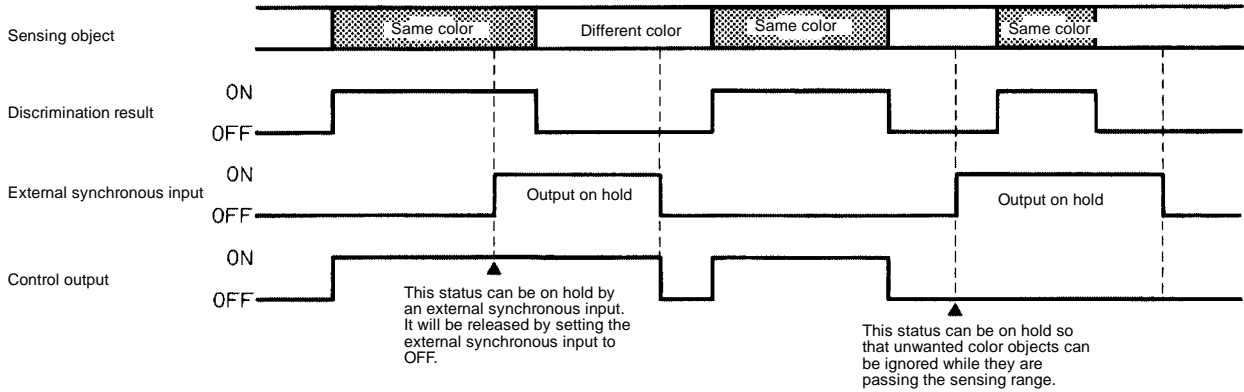

Remote Teaching (Remote Control Function)

Mode Setting

When using the remote control function of the Sensor for remote teaching, be sure to set the Sensor to mode B.

Setting Method

Apply power to the Sensor while pressing the SELECT DOWN button and TEACH button together.

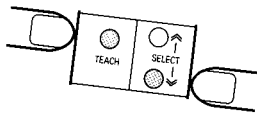

Checking Method

Mode A or B of the E3MC will be displayed for 3 s after mode setting. When the mode selector is set to TEACH, the mode can be checked from the operation indicator. The indicator will be lit when the mode is set to B.

Mode A:
Operation indicator is OFF.

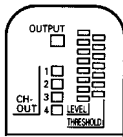

Mode B:
Operation indicator is ON.

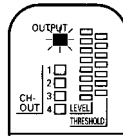

- Note:**
1. The Sensor is set to mode A before shipping.
 2. The current mode selected does not change after the Sensor is turned OFF.
 3. The remote control function is available in RUN mode and ADJ mode only.
 4. The E3MC-Mj has three outputs in mode B and no external synchronous input will be accepted.
 5. The same switching procedure can be used for changing to mode A.

Remote Teaching Method

Function 1: Remote teaching with manual input through a mechanical switch

Short-circuit the remote control input for 1.5 s or more to either of the following terminals according to the E3MC model.

NPN type (E3MC-j j 11)	Short-circuit to GND (blue) terminal.
PNP type (E3MC-j j 41)	Short-circuit to Vcc (Brown) terminal.

Function 2: Remote control of teaching and bank selection through the PLC or PT

Input one of the following signals as a remote control input. There will be an answer-back output for 0.3 s if the signal is correctly received.

No.	Control signal	E3MC-j	E3MC-Mj j
1	ON pulse 0.3s	Bank 1 selected.	Channel 1 selected.
2	ON pulse 0.6s	Bank 2 selected.	Channel 2 selected.
3	ON pulse 0.9s	Bank 3 selected.	Channel 3 selected.
4	ON pulse 1.2s	Bank 4 selected.	Not used.
5	ON pulse 1.5s	Teaching of selected bank.	Teaching of selected channel.

The following is an example of ladder programming.

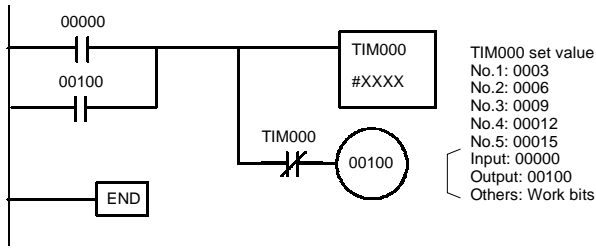

The following is an example of a timing chart of teaching after bank selection.

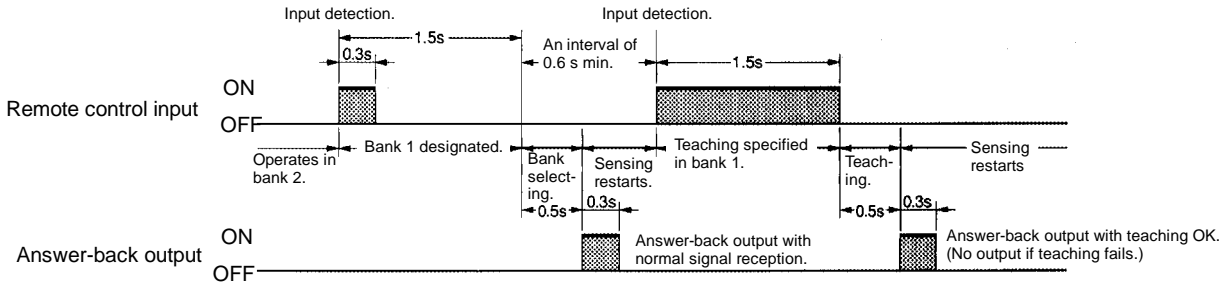

Function 3: Remote control of threshold adjustments through the PLC or PT

Input either one of the following signals as remote control input. There will be an answer-back output for 0.3 s if the signal is correctly accepted.

No.	Control signal	All E3MC models
6		Threshold 1 selected.
7		Threshold 2 selected.
8		Threshold 3 selected.
9		Threshold 4 selected.
10		Threshold 5 selected.
11		Threshold 6 selected.
12		Threshold 7 selected.

Threshold and Display

- Threshold 1
- Threshold 2
- Threshold 3
- Threshold 4
- Threshold 5
- Threshold 6
- Threshold 7

The following is an example of ladder programming for setting control signals. Full control of the E3MC is possible using this function together with function 2.

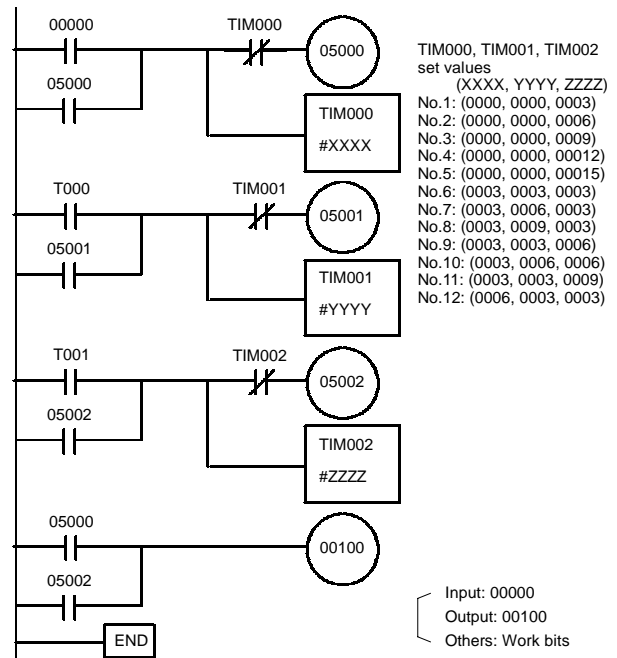

- Note:**
1. The permissible error of each signal pulse is ± 0.1 s max.
 2. A minimum interval of 0.6 s is required between signals.
 3. Threshold 4 is set after teaching.

Dimensions

Note: All units are in millimeters unless otherwise indicated.

■ RGB Color Sensors

E3MC-Aj j
E3MC-MAj j

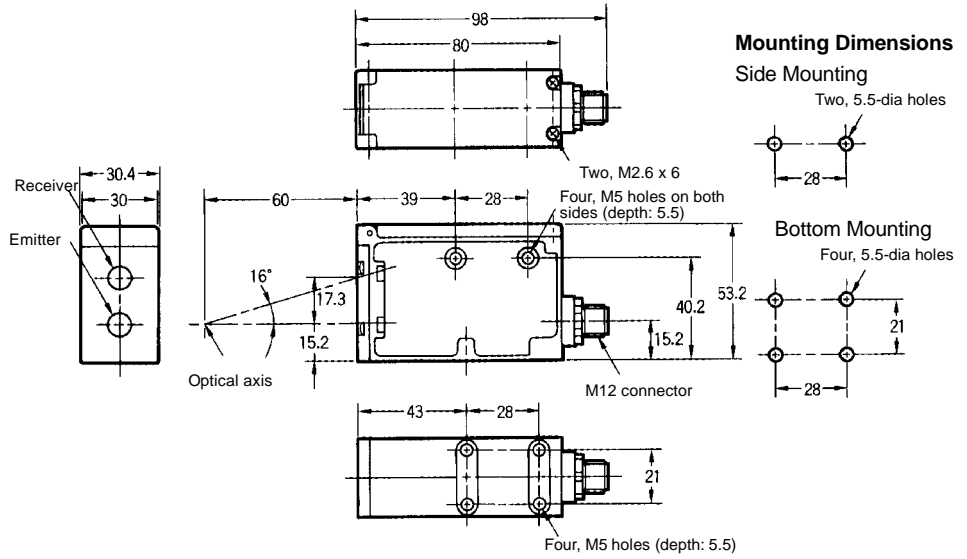
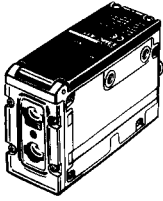

E3MC-Xj j
E3MC-MXj j

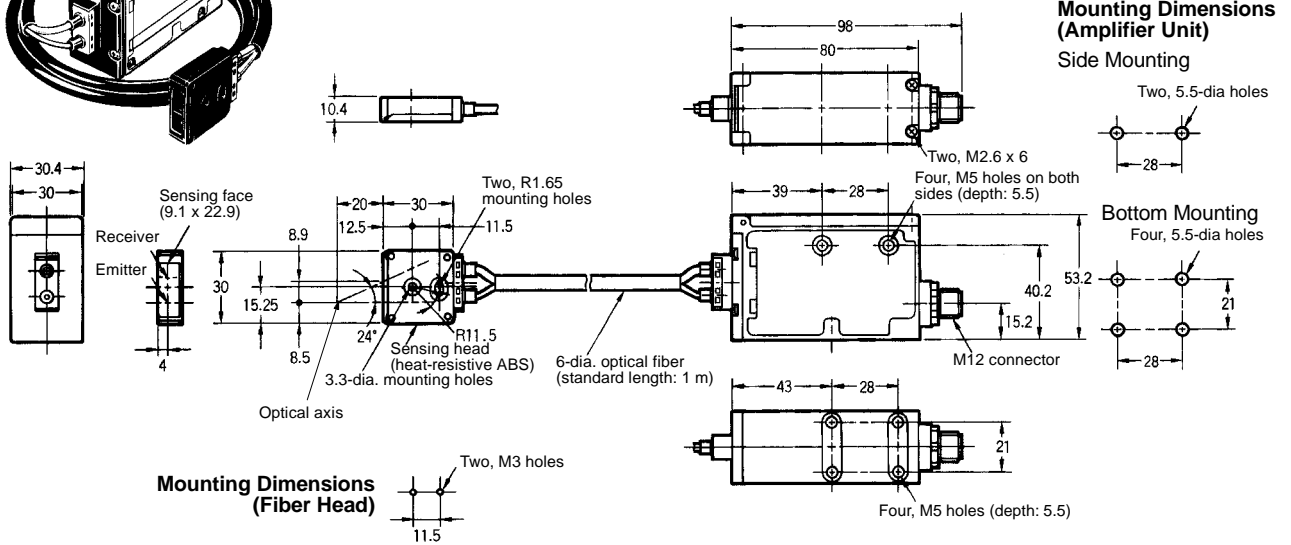
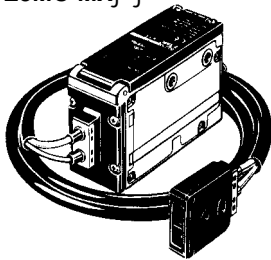

E3MC-Yj j
E3MC-MYj j

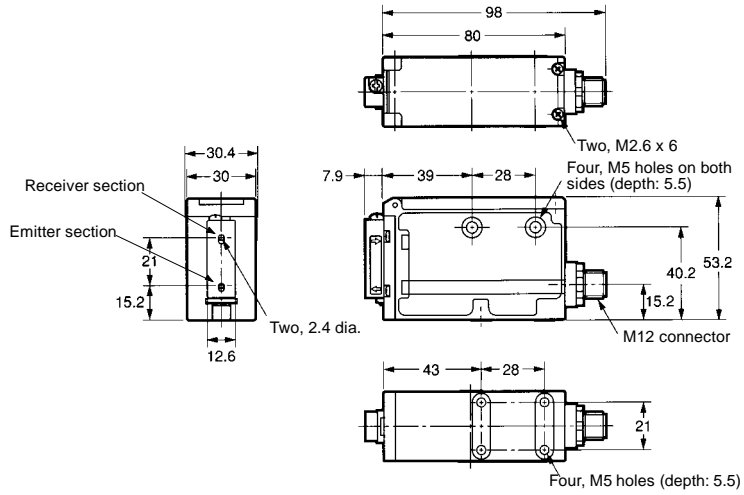
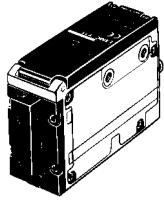

Mounting Dimensions (Amplifier Unit)

Side Mounting

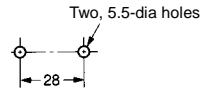

Bottom Mounting

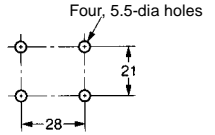

■ Accessories (Order Separately) (2-m Cord is Provided with the E3MC)

Sensor I/O Connector
E39-C1 2M: 2 m*
E39-C1 5M: 5 m*

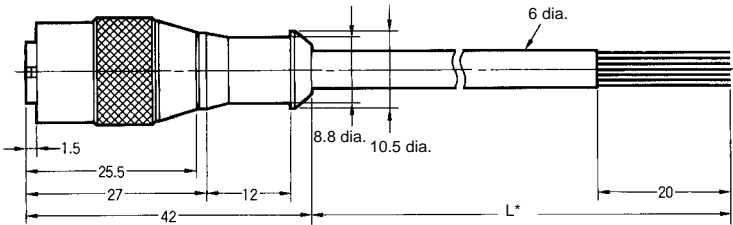

Sensor Mounting Bracket
E39-L114

Mounting Dimensions

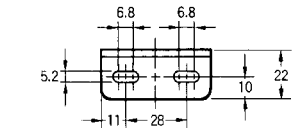

When using the E3MC-j X Mounting Bracket

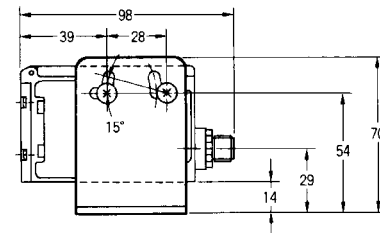
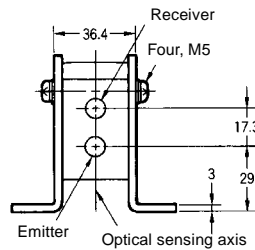
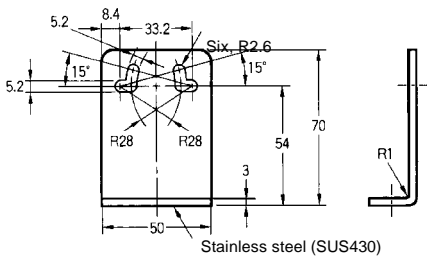
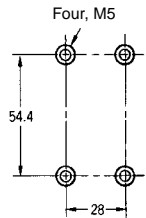
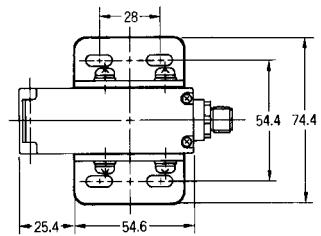

**DIN-track Mounting Bracket
E39-L115**

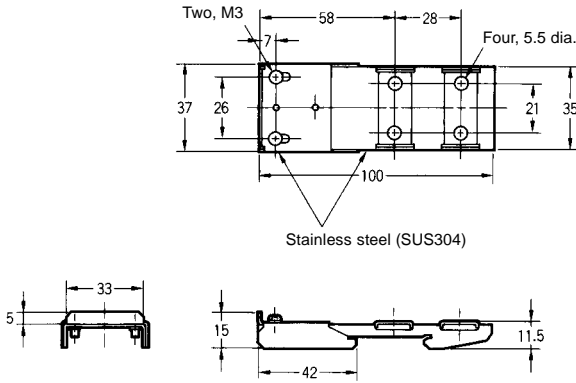

When using the E3MC-j A Mounting Bracket

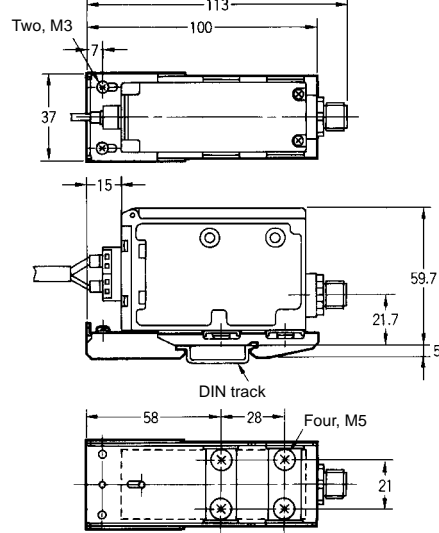

Installation

■ Plug (Sensor I/O Connector)

E39-C1 2M
E39-C1 5M

Internal Wiring

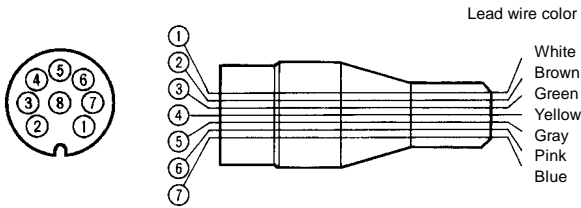

Note: Pin 8 is not used.

Connection

Pin no.	Wire color	Purpose	
		E3MC-j 11 E3MC-j 41	E3MC-Mj 11 E3MC-Mj 41
1	White	Output	Output 1
2	Brown	Power supply (+V)	
3	Green	Bank selection input 2	Output 4
4	Yellow	Bank selection input 1	Output 3
5	Gray	---	Output 2
6	Pink	External synchronous input	
7	Blue	Power supply (0V)	

Precautions

General

Do not impose any voltage exceeding the rated voltage on the E3MC, otherwise the E3MC may be damaged.

When supplying power to the E3MC, make sure that the polarity of the power is correct, otherwise the E3MC may be damaged.

Do not short-circuit the load connected to the E3MC, otherwise the E3MC may be damaged.

Optical Fiber Type

Tightening Torque

The Fiber Unit must be tightened to a maximum torque of 0.54 N S m (5.4 kgf S cm).

Mounting

When Fiber Units are mounted to face each other, make sure to adjust the optical axes so that the Fiber Units will not be mutually interfered.

Handling the Fiber Unit

- Do not pull or press the Fiber Unit.
- Do not bend the Fiber Unit beyond 10 mm.
- Do not bend the edge of the Fiber Unit.

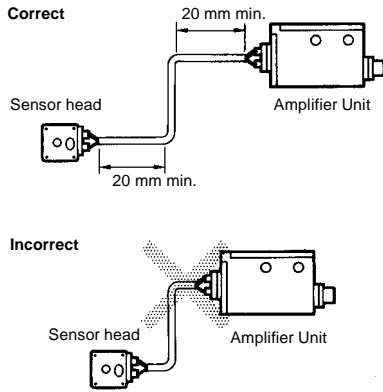

Do not apply excess force on the Fiber Unit.

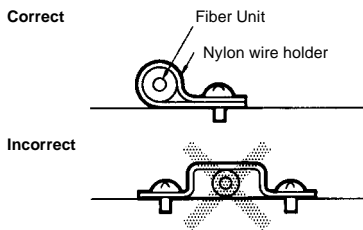

The Fiber Head could be broken by excessive vibration. To prevent this, the following is effective:

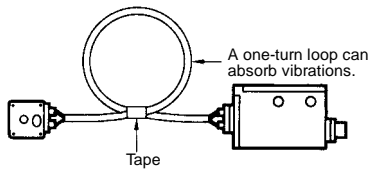

General-purpose Optical Fiber Type

Insertion

The inserted Fiber Unit comes in contact with the internal rubber packing first. Insert the Fiber Unit further until it comes in contact with the innermost end.

Mounting

Tighten the Fiber Unit with a screwdriver to a torque of 0.2N S m (2 kgf S cm).

Fibers

Among the recommended fibers, the E32-CC200 and E32-D32L have white or dotted yellow lines on the fiber to be inserted into the emitter. When using the E3MC-(M)Yj j , insert the fiber with the line into the emitter section at the bottom of the amp.

Fiber Unit

Tightening Torque

When mounting the Fiber Unit, refer to the following table and make sure that the tightening torque applied is correct.

Screw-mounting Type

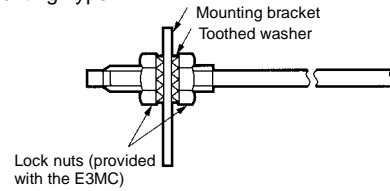

Column Type

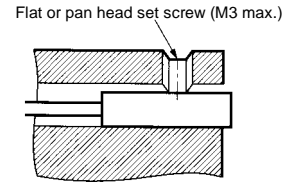

Fiber Unit	Tightening torque
M3 screw	0.78 N S m {8 kgf S cm} max.
M4 screw	
M6 screw	0.98 N S m {10 kgf S cm} max.
2-dia column	0.29 N S m {3 kgf S cm} max.
3-dia column	0.29 N S m {3 kgf S cm} max.
E32-T16	0.49 N S m {5 kgf S cm} max.

Make sure that the size of the wrench applied to the nut is correct.

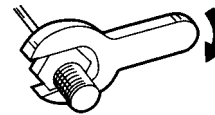

Fiber Cutting

Insert the fiber into one of the insertion holes of the Cutting Tool to cut the fiber to the desired length. Press down the blade of the Cutting Tool to cut the fiber in a single stroke. Do not stop the Cutting Tool midway.

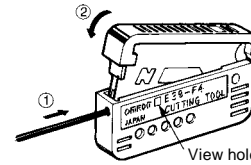

Each insertion hole can be used only once. Do not use it again, otherwise the fiber may not be cut properly and the sensing distance may decrease.

Connection

Do not pull the Fiber Unit with force exceeding 9.8 N (1 kgf) or press the Fiber Unit with force exceeding 29.4 N (3 kgf). The fiber is so thin that the utmost attention will be required to handle the fiber.

Do not bend the Fiber Unit beyond the permissible bending radius provided in *Ratings/Characteristics*.

Do not bend the end of the Fiber Unit.

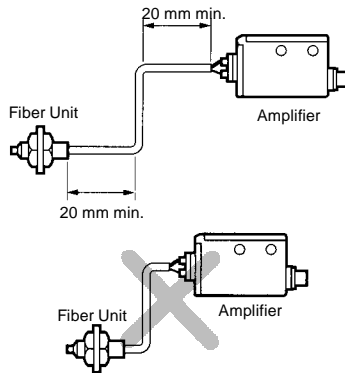

Do not press or place a load on the Fiber Unit.

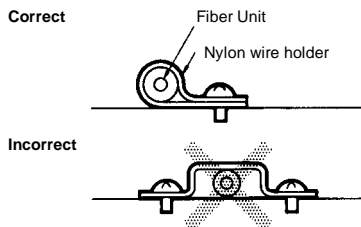

The Fiber Head can be broken by excessive vibration. To prevent this, the following is effective.

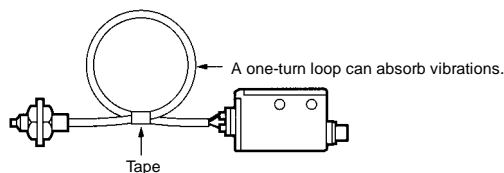

Built-in Amplifier Type

Tightening Torque

The Amplifier Unit must be tightened to a maximum torque of 2.3 N S m (23 kgf S cm).

Mounting

When Sensors are mounted to face each other, make sure to adjust the optical axes so that the Sensors will not be mutually interfered.

Installation

Power Reset Time

The E3MC is ready to sense objects from 100 ms after the E3MC is turned ON, until when no devices connected the E3MC can be used. Be sure to turn ON the E3MC first if power is supplied to the E3MC and the load independently.

When the E3MC is turned ON or OFF, the operation indicator will be ON for an instant but no control output will be turned ON.

When using the Sensor for fine sensing, allow the system to warm up for approximately 15 min after turning ON the power supply.

Power OFF

The E3MC may output a single pulse when the control power supply is turned OFF. If the E3MC is connected to a timer or counter to which power is supplied from an independent power supply, the E3MC will be more likely to output a single pulse when the control power supply is turned OFF. Therefore, supply power to the timer or counter from the same power supply for the E3MC.

Types of Power Supplies

No full-wave or half-wave rectified power supplies can be connected to the E3MC.

Power Supplies

Be sure to ground the FG (frame ground) and G (ground) terminals if a switching regulator is connected to the E3MC, otherwise the E3MC may malfunction due to the switching noise of the switching regulator.

Wiring

Cord

The cord can be extended up to 100 m provided that the thickness of the cord is 0.3 mm² maximum.

Repeated Bending

The cord must not be bent repeatedly.

High-tension Lines

The power supply lines of the Photoelectric Sensor must not be wired alongside power lines or high-tension lines in the same conduit, otherwise the Photoelectric Sensor may become damaged or malfunction due to induction noise that may be generated from the power lines or high-tension lines. Route the lines separately or in a single conduit.

Cord Pulling Force

Do not pull cords with pulling forces exceeding 50N.

Others

EEPROM Error

An EEPROM error may result if power supply to the Sensor fails or the Sensor is influenced by static noise. The operation and bank indicators will flash and the buzzer will beep if there is an EEPROM error, in which case perform teaching and make threshold level settings again.

M12 Metal Connector

Make sure to connect or disconnect the metal connector after turning off the E3MC.

Make sure to hold the connector cover when connecting or disconnecting the metal connector.

Tighten the metal connector securely by hand. Do not use any tool, such as pliers, otherwise the metal connector may be damaged.

If the metal connector is not tightened securely, the metal connector may be disconnected by vibration or the proper degree of protection of the E3MC may not be maintained.

Water Precaution

Avoid using the Sensor in water, rain, or outdoors.

Protective Cover

Tighten the operation cover to a torque of 0.2 to 0.3 N S m to ensure proper waterproofing.

DIN Track Mounting/Removal with the E39-L115

Mounting

1. Attach the E39-L115 Mounting Bracket to the E3MC with four M5 screws.

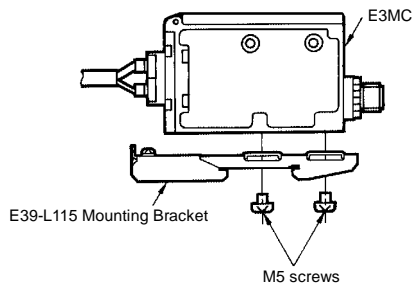

2. When mounting the E3MC with the E39-L115, loosen the M3 screw of the E39-L115 and slide part A in the direction indicated by arrow (1) as shown in the following illustration.

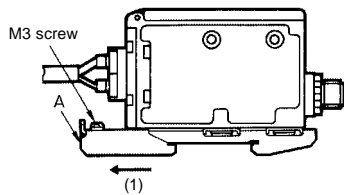

3. Mount part (2) to the DIN track.

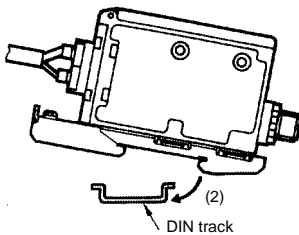

4. Press the E3MC in the direction indicated by arrow (3) and slide part A in the direction indicated by arrow (4) as shown in the following illustration until the E39-L115 correctly engages with the DIN track.

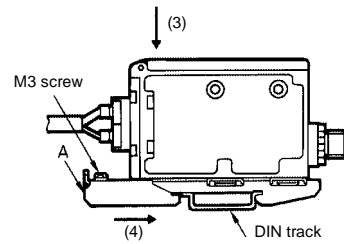

5. Tighten the M3 screw of the E39-L115 to secure the E39-L115.

Removal

Loosen the M3 screw of the E39-L115, press the E3MC in the direction indicated by arrow (5) and slide part A in the direction indicated by arrow (6). Then lift up the E3MC in the direction indicated by arrow (7) to remove the E3MC with the E39-L115.

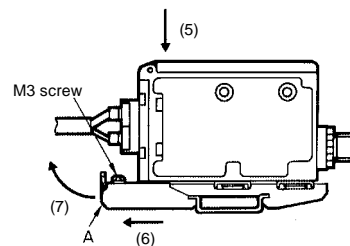

ALL DIMENSIONS SHOWN ARE IN MILLIMETERS.

To convert millimeters into inches, multiply by 0.03937. To convert grams into ounces, multiply by 0.03527.

Cat. No. E256-E1-3 In the interest of product improvement, specifications are subject to change without notice.

OMRON Corporation

Industrial Sensors Division
Sensing Devices and Components Division H.Q.
28th Fl., Crystal Tower Bldg.,
1-2-27, Shiromi, Chuo-ku,
Osaka 540-6028 Japan
Phone: (81)6-949-6012 Fax: (81)6-949-6021

Printed in Japan
0398-2M (0297) a