

Basic Switch

D2F

Subminiature Basic Switch

- Super compact, ideal for PCB mounting
- Switches 3 A loads (general-purpose), 1 A loads (low force general-purpose) and 0.1 A loads (microvoltage/microcurrent)
- Long life span assured by high-precision dual spring reverse-action mechanism
- Flux penetration prevented by using an insert terminal and allowing a height difference at the case bottom
- Ideal for a wide variety of applications from household appliances and office equipment to audio equipment and communications equipment



Ordering Information

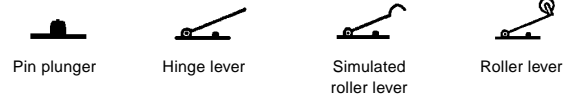

| Actuator | Contact type | Model | Con- tact OF | Part Number | | | | |
|---------------------------|--------------------------|-----------|--------------------|---------------|-----------------|-------------|-------------|--------------|
| | | | | Terminal type | | | | |
| | | | | PCB | Self-supporting | Soldered | Right-angle | Left-angle |
| Pin plunger | Microvoltage/ current | Low force | 75 g | D2F-01F | D2F-01F-T | D2F-01F-D | D2F-01F-A | D2F-01F-A1 |
| | | Standard | 150 g | D2F-01 | D2F-01-T | D2F-01-D | D2F-01-A | D2F-01-A1 |
| | General- purpose | Low force | 75 g | D2F-F | D2F-F-T | D2F-F-D | D2F-F-A | D2F-F-A1 |
| | | Standard | 150 g | D2F | D2F-T | D2F-D | D2F-A | D2F-A1 |
| Hinge lever | Microvoltage/ current | Low force | 25 g | D2F-01FL | D2F-01FL-T | D2F-01FL-D | D2F-01FL-A | D2F-01FL-A1 |
| | | Standard | 80 g | D2F-01L | D2F-01L-T | D2F-01L-D | D2F-01L-A | D2F-01L-A1 |
| | General- purpose | Low force | 25 g | D2F-FL | D2F-FL-T | D2F-FL-D | D2F-FL-A | D2F-FL-A1 |
| | | Standard | 80 g | D2F-L | D2F-L-T | D2F-L-D | D2F-L-A | D2F-L-A1 |
| Simulated roller lever | Microvoltage/ current | Low force | 40 g | D2F-01FL3 | D2F-01FL3-T | D2F-01FL3-D | D2F-01FL3-A | D2F-01FL3-A1 |
| | | Standard | 80 g | D2F-01L3 | D2F-01L3-T | D2F-01L3-D | D2F-01L3-A | D2F-01L3-A1 |
| | General- purpose | Low force | 40 g | D2F-FL3 | D2F-FL3-T | D2F-FL3-D | D2F-FL3-A | D2F-FL3-A1 |
| | | Standard | 80 g | D2F-L3 | D2F-L3-T | D2F-L3-D | D2F-L3-A | D2F-L3-A1 |
| Roller lever | Microvoltage/ current | Low force | 40 g | D2F-01FL2 | D2F-01FL2-T | D2F-01FL2-D | D2F-01FL2-A | D2F-01FL2-A1 |
| | | Standard | 80 g | D2F-01L2 | D2F-01L2-T | D2F-01L2-D | D2F-01L2-A | D2F-01L2-A1 |
| | General- purpose | Low force | 40 g | D2F-FL2 | D2F-FL2-T | D2F-FL2-D | D2F-FL2-A | D2F-FL2-A1 |
| | | Standard | 80 g | D2F-L2 | D2F-L2-T | D2F-L2-D | D2F-L2-A | D2F-L2-A1 |

CONTACT FORM

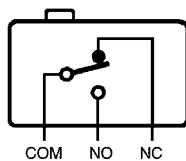

Specifications

| | | | | |
|---------------|----------------------|----------|-----------------|----------|
| | Resistive load | | | |
| | Microvoltage/current | | General-purpose | |
| Rated Voltage | Low force | Standard | Low force | Standard |
| 125 VAC | — | — | 1 A | 3 A |
| 30 VDC | 0.1 A | 0.1 A | 0.5 A | 2 A |

Note: When using an inductive load or motor load, consult OMRON.

Characteristics

| | | |
|-----------------------|---|---|
| Operating speed | | 1 to 500 mm/second (0.04 to 19.7 in./second) |
| Operating frequency | Mechanical | 200 operations per minute (pin plunger actuator type) |
| | Electrical | 30 operations per minute (pin plunger actuator type) |
| Contact resistance | General-purpose type | 30 mΩ max. (initial) |
| | Microvoltage/ microcurrent load type | 100 mΩ max. (initial) |
| Insulation resistance | | 100 MΩ min. at 500 VDC |
| Dielectric strength | | 600 VAC, 50/60 Hz for 1 minute between terminals of same polarity 1,500 VAC, 50/60 Hz for 1 minute between current-carrying parts and ground |
| Vibration | Malfunction durability | 10 to 55 Hz, 1.5 mm double amplitude |
| Shock | Malfunction durability | 300 m/s ² min. (approx. 30 g min.) |
| Ambient temperature | Operating | -25° to 65°C with no icing |
| Humidity | Operating | 45% to 85% at 5° to 35°C |
| Service life | Mechanical | 1 million operations min. (OT: full stroke) |
| | Electrical | 30,000 operations min. (rated load) |
| Weight | | Approx. 0.5 g |

Note: Data shown are of initial value.

CHARACTERISTIC DATA

Mechanical service life

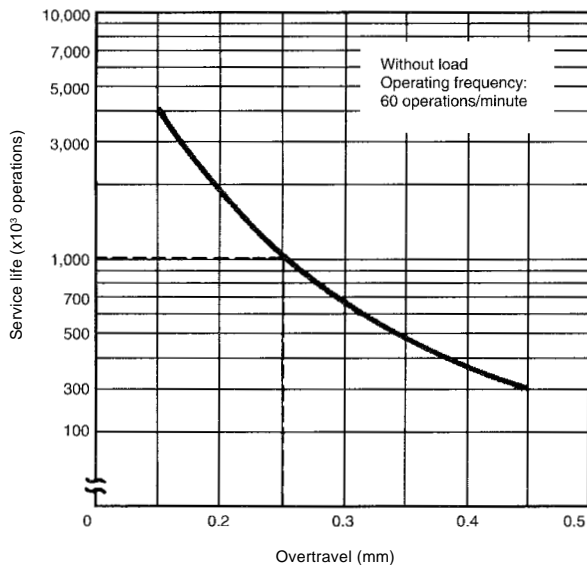

Electrical service life

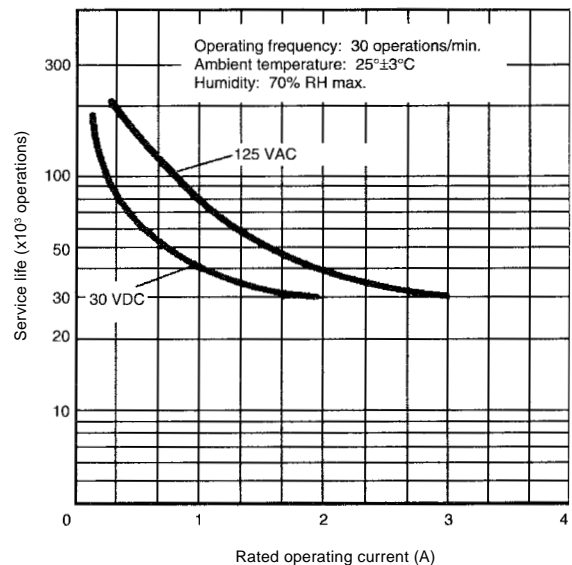

Note: 1. Values are for pin plunger actuator type.

Dimensions

Unit: mm (inch)

Pin plunger

D2F-01-□, D2F-01F-□, D2F-□, D2F-F-□

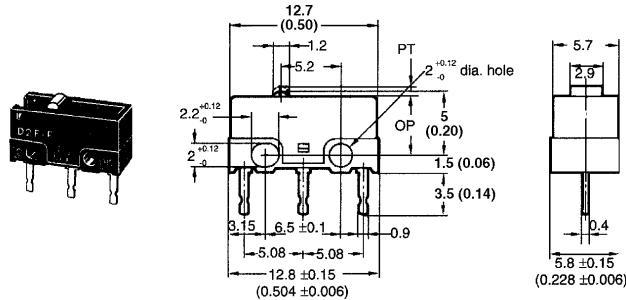

| Operating characteristics | D2F-01F-□ D2F-F-□ | D2F-01-□ D2F-□ |
|---------------------------|-----------------------------------|-----------------------------------|
| OF max. | 75 g | 150 g |
| RF min. | 5 g | 20 g |
| PT max. | 0.5 mm (0.020 in) | 0.5 mm (0.020 in) |
| OT min. | 0.25 mm (0.009 in) | 0.25 mm (0.009 in) |
| MD max. | 0.12 mm (0.005 in) | 0.12 mm (0.005 in) |
| OP | 5.5 ± 0.3 mm (0.22 ± 0.012 in) | 5.5 ± 0.3 mm (0.22 ± 0.012 in) |

Hinge lever

D2F-01L-□, D2F-01FL-□, D2F-L-□, D2F-FL-□

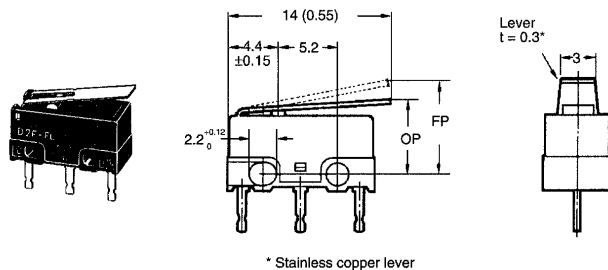

| Operating characteristics | D2F-01FL-□ D2F-FL-□ | D2F-01L-□ D2F-L-□ |
|---------------------------|------------------------------------|------------------------------------|
| OF max. | 25 g | 80 g |
| RF min. | 2 g | 5 g |
| OT min. | 0.55 mm (0.022 in) | 0.55 mm (0.022 in) |
| MD max. | 0.5 mm (0.020 in) | 0.5 mm (0.020 in) |
| OP | 6.8 ± 1.5 mm (0.267 ± 0.059 in) | 6.8 ± 1.5 mm (0.267 ± 0.059 in) |
| FP* max. | 10 mm (0.394 in) | 10 mm (0.394 in) |

* Free position

Simulated roller lever

D2F-01L3-□, D2F-01FL3-□, D2FL3-□, D2F-FL3-□

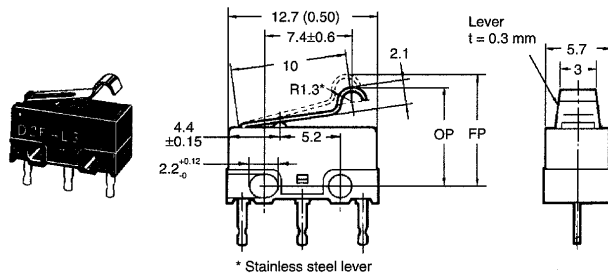

| Operating characteristics | D2F-01FL3-□ D2F-FL3-□ | D2F-01L3-□ D2FL3-□ |
|---------------------------|------------------------------------|------------------------------------|
| OF max. | 40 g | 80 g |
| RF min. | 2 g | 5 g |
| OT min. | 0.5 mm (0.020 in) | 0.5 mm (0.020 in) |
| MD max. | 0.45 mm (0.177 in) | 0.45 mm (0.177 in) |
| OP | 8.5 ± 1.2 mm (0.335 ± 0.047 in) | 8.5 ± 1.2 mm (0.335 ± 0.047 in) |
| FP* max. | 13 mm (0.512 in) | 13 mm (0.512 in) |

* Free position

Roller lever

D2F-01L2-□, D2F-01FL2-□, D2F-L2-□, D2F-FL2-□

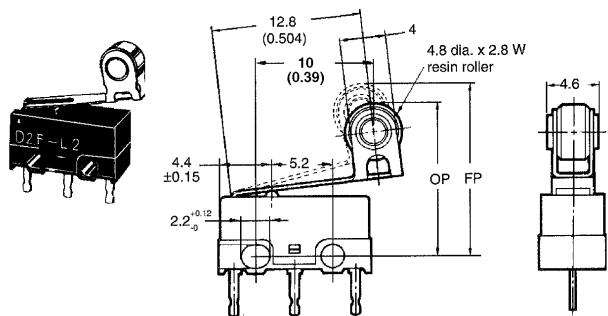

| Operating characteristics | D2F-01FL2-□ D2F-FL2-□ | D2F-01L2-□ D2FL2-□ |
|---------------------------|-----------------------------------|-----------------------------------|
| OF max. | 40 g | 80 g |
| RF min. | 2 g | 5 g |
| OT min. | 0.55 mm (0.022 in) | 0.55 mm (0.022 in) |
| MD max. | 0.5 mm (0.020 in) | 0.5 mm (0.020 in) |
| OP | 13 ± 2.0 mm (0.512 ± 0.079 in) | 13 ± 2.0 mm (0.512 ± 0.079 in) |
| FP* max. | 16.5 mm (0.650 in) | 16.5 mm (0.650 in) |

* Free position

Note: 1. Unless otherwise specified, a tolerance of ± 0.4 mm applies to all dimensions.

2. Omitted dimensions are the same as pin plunger type.

3. Letters and numbers which identify the terminal are put in the blank box of the part number.

4. The above illustrations and dimensions are for models with PCB terminals. Refer to "Terminals" for models with self-supporting, solder and right/left angle terminals.

Unit: mm (inch)

■ TERMINALS

D2F type
PCB terminal

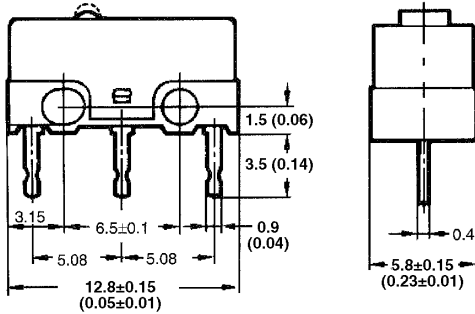

D2F-T type
Self-supporting terminal

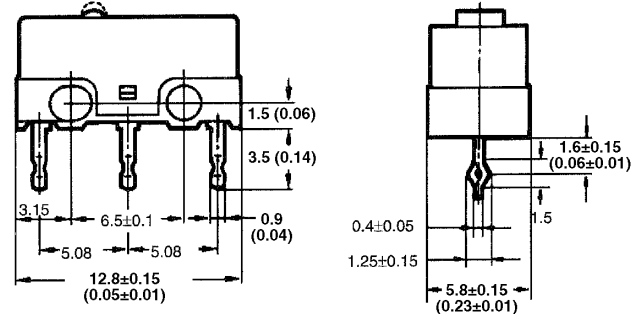

D2F-D type
Soldered terminal

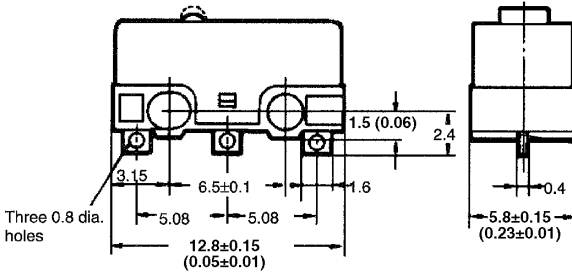

D2F-A type
Right-angle terminal

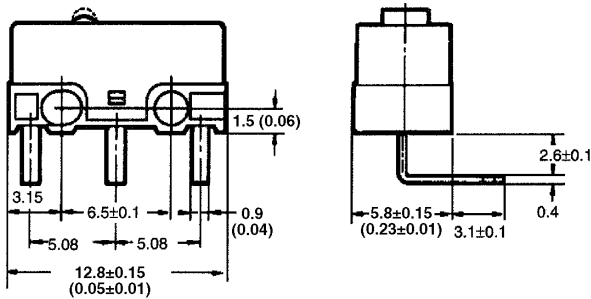

D2F-A1 type
Left-angle terminal

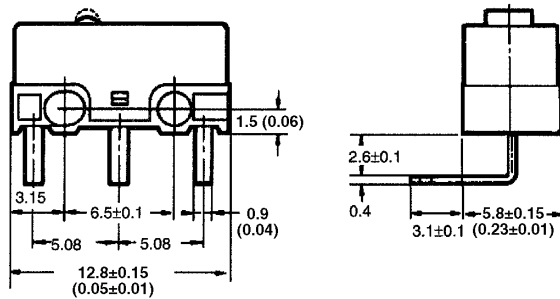

■ APPROVALS

UL (File No. E41515) / CSA (File No. LR21642)

| Type | Rating |
|---------------------------|---|
| D2F Series, D2F-01 Series | 3 A, 125 VAC 1 A, 125 VAC 2 A, 30 VDC 0.5 A, 30 VDC 0.1 A, 30 VDC |

Note: The rated values approved by each of the safety standards (e.g. UL, CSA) may be different from the performance characteristics individually defined in this catalog.

Precautions

■ MOUNTING

Mount the D2F switch onto the PC board as shown in the following diagram, using 2-pitch (2 x 2.54 mm) terminal spacing.

■ PC BOARD MACHINING

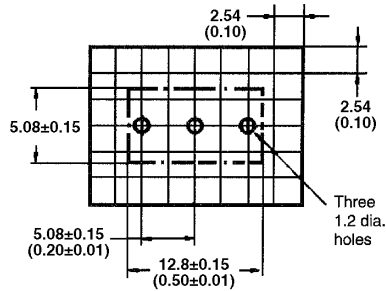

■ DIMENSIONS

The use of molded components is recommended for mounting purposes.

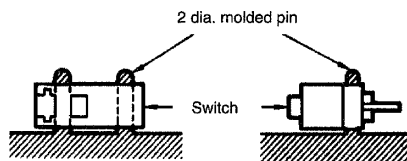

■ MOLDED PIN MOUNTING DIAGRAM

When screw mounting, use M2 screws together with washers. Fasten the screws applying 0.8 to 1 kg-cm tightening torque.

■ MOUNTING HOLE MACHINING

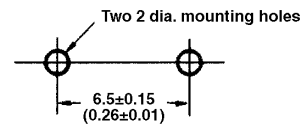

■ DIMENSIONS

When soldering, use 6:4 solder and a 60 W soldering iron, and complete soldering within 3 seconds. After soldering, do not apply external force to the soldered area for about 1 minute.

Allow sufficient insulation distance between terminals and between terminals and ground.

OMRON

Omron Europe B.V. EMA-ISD, tel:+31 23 5681390, fax:+31 23 5681397, <http://www.eu.omron.com/ema>